



An interactive agent-based modelling framework for assessing COVID-19 transmission risk on construction site

Qingyao Qiao^a, Clara Cheung^b, Akilu Yunusa-Kaltungo^b, Patrick Manu^{c,*}, Ruifeng Cao^b, Ziyue Yuan^d

^a Healthy High Density City Lab, Faculty of Architecture, The University of Hong Kong, Hong Kong

^b Department of Mechanical, Aerospace and Civil Engineering (MACE), The University of Manchester, M13 9PL, United Kingdom

^c School of Architecture and Environment, University of the West of England, Bristol BS16 1QY, United Kingdom

^d Department of Civil and Environmental Engineering, Hong Kong Polytechnic University, Hong Kong

ARTICLE INFO

Keywords:

COVID-19
SEIR model
Construction site
Agent-based modelling
Safety control measures

ABSTRACT

The outbreak of COVID-19 has impacted the world and society in its entirety. The labour-intensive construction industry is especially disrupted by COVID-19 and construction workers have a higher chance of exposure to COVID-19. Despite the extensiveness of qualitative and quantitative research around the impact of COVID-19 on the construction industry, it is observed that very limited proportion of such research actually investigated the COVID-19 dynamics within a specific construction site as well as the effectiveness of the corresponding safety control measures. Given this context, this study developed an interactive agent-based modelling framework embedded with a modified susceptible-exposed-infectious-recovered (SEIR) model for assessing COVID-19 transmission risk on construction sites, with the application of five safety control measures (i.e., SCM including face covering, vaccination, ventilation, social distance and isolation). This study afterwards set up 108 SCM scenarios based on the five SCM and sensitivity analyses were conducted in order to generate robust results. Based on the simulation results, the efficacy of the 5 SCM in preventing COVID-19 spread was assessed. Therefore, the results of the 108 scenarios are a useful scientific reference for stakeholders or policymakers when making decisions regarding mitigating the spread of COVID-19 and other infectious diseases within the construction sector.

1. Introduction

COVID-19, caused by severe acute respiratory syndrome coronavirus 2 (i.e., SARS-CoV-2), is considered an extremely infectious disease that transmits from person to person mainly via airborne droplets disseminated by breathing, talking, sneezing, coughing, etc (Nundy et al., 2021; Yuan et al., 2022). According to the World Health Organization (WHO), since the first outbreak in December 2019, the COVID-19 pandemic has caused unprecedented fatalities and posed huge challenges to public health, with more than 630 million cases of infections, including 6.5 million deaths (World Health Organization, 2021).

In order to curb or flatten the Covid-19 infection curve, governments have implemented a variety of aggressive policies/measures, including dispatching vaccination, enforcing social/ physical distance (both social/physical distance means creating physical distance between people

to decrease the risk of transmission, and the term social distance is used to represent such actions throughout the following sections), isolation rules, and closing public buildings and spaces (e.g., shopping centres, schools, universities and offices) (Zhao et al., 2022; Yuan et al., 2023). To support government decision making, efforts have been made by scholars to develop a comprehensive understanding of COVID-19 transmission dynamics and its associated prevention strategies (Issa, 2021; Mourad et al., 2022; Uddin, 2023; Varotsos, 2021; Varotsos et al., 2021; Varotsos and Krapivin, 2020). Besides, in response to the adverse impact on society and economic operations, many industries have widely adopted hybrid working to prevent COVID-19 transmission. However, hybrid working is not always feasible, especially for some essential sectors (e.g., health care, transportation and energy) as well as some labour-intensive industries (e.g., construction and logistics) due to the nature of their jobs. For instance, in the UK, the construction sector

* Corresponding author.

E-mail addresses: qingyaoq@hku.hk (Q. Qiao), clara.cheung@manchester.ac.uk (C. Cheung), akilu.kaltungo@manchester.ac.uk (A. Yunusa-Kaltungo), patrick.manu@uwe.ac.uk (P. Manu), ruifeng.cao@manchester.ac.uk (R. Cao), ziyue.yuan@connect.polyu.hk (Z. Yuan).

<https://doi.org/10.1016/j.ssci.2023.106312>

Received 9 March 2023; Received in revised form 8 August 2023; Accepted 10 September 2023

Available online 28 September 2023

0925-7535/© 2023 The Author(s). Published by Elsevier Ltd. This is an open access article under the CC BY license (<http://creativecommons.org/licenses/by/4.0/>).

has been maintained during the pandemic as admitted by the government (Jallow et al., 2021). Similarly, as reported by the Hong Kong Construction Industry Council (HKCIC), more than 10,000 workers continued their regular duties on construction sites in December 2020 (Xu et al., 2021). Compared with other industries, many tasks within the construction industry require physical proximity and high-intensive physical activities (leading to a higher breathing rate and perspiration) of construction workers which facilitate the spread of COVID-19. Previous research (Allan-Blitz et al., 2020; Pasco et al., 2020) has shown that among many industries, the construction industry has the highest infection rate of COVID-19, and the hospitalisation rate is five times the average level of other industries.

Health and Safety concerns regarding COVID-19 transmission risk in workplaces within the construction industry have been extensively studied since the breakout of COVID-19 pandemic. For instance, Alsharif et al. (2021) studied the early impact of the COVID-19 pandemic on the construction industry in the United States by interviewing 34 professionals. Many participants emphasised the unprecedented healthy risk caused by COVID-19 and the necessity of implementing rigorous safety control measures (SCM) to eliminate or reduce the spread of the virus. Apart from the previously mentioned close proximity and heavy labour work, some other challenges also contributed to the difficulty of a safe workplace. For instance, the majority of infected cases are asymptomatic and even for those who are symptomatic, there is a delay before symptom onset. Stiles et al. (2021) also pointed out that the health impact caused by the pandemic together with the conventional aspects of hazards have led to unprecedented challenges.

An accurate and reasonable estimation of the COVID-19 transmission risk on construction sites is a prerequisite for implementing corresponding safety control measures. However, such quantitative research currently is still limited due to the complex nature of COVID-19 dynamics and human behaviour. A mathematical model of COVID-19 transmission with construction workers in the Austin-Round Rock area was proposed by Pasco et al. (2020). Their model explored the association between construction work and hospitalisation rates under different age and risk group settings. However, as a top-to-bottom method, the proposed model was not able to be implemented on a specific construction site. Statistical analysis based on questionnaires has been extensively employed to understand the impact of COVID-19 on construction sites. For instance, Olanrewaju et al. (Olanrewaju et al., 2021) investigated the impact of COVID-19 and validated the corresponding measures on 4 construction sites based on the outcomings from questionnaires. Despite their research being able to quantify the effectiveness of COVID-19 impact on a specific construction site, it is however, difficult to develop a detail dynamic of COVID-19 on a construction site due to the limitation of the questionnaire (e.g., does not include temporal dimension information). Therefore, there is an urgent need for a comprehensive understanding and quantification of COVID-19 transmission risk on construction sites. Meanwhile, accurate access to corresponding SCM in preventing COVID-19 transmission is also pivotal for decision-making. Based on the above premise, this study proposed a hybrid ABM-SEIR model for simulating the dynamics of COVID-19 transmission on a construction site and the epidemiological effects of various safety control measures that were prevalent at the time, which incorporates an interactive graphical user interface (GUI) and includes 2D and 3D animations to visualise the simulation results. Although the emphasis of this study was on COVID-19, it should be noted that the theoretical framework and methodology proposed here can be implemented for other communicable diseases by simply changing or integrating the relevant control measures and attributes of such diseases and the studied environment. The structure of the paper is as follows: Section 2 presents a brief review of the existing research on simulating COVID-19 transmission. A comprehensive COVID-19 simulation together with a safety control measure assessment design is depicted in Section 3. Section 4 summaries the main results of the study, followed by a conclusion

and further discussions in Section 5.

2. Literature review

In order to alleviate the health and safety threats posed by COVID-19 on construction workers, it is essential to develop a COVID-19 transmission model that can accurately simulate the spread of the virus on construction sites and then based on the developed model, the effectiveness of the corresponding SCM can be quantified so as to provide scientific evidence for decision-making.

The mathematical model namely susceptible-infectious-recovered (SIR) is one of the most popular models for epidemiology simulation.

Since the breakout of COVID-19 pandemic, SIR-based models have been extensively applied to characterise COVID-19 transmission dynamics. It is noticed that SIR-based modelling was predominantly applied for macro-scale scenarios. For instance, Afkhamiaghda and Elwakli (Afkhamiaghda and Elwakli, 2020) developed a preliminary model using SIR modelling to simulate COVID-19 spread in the construction industry. Chen et al. (Chen et al., 2021) combined an SEIR model of COVID-19 with an economic model to discuss the economic losses to different sectors, including the construction industry and the effects of epidemic prevention measures. Yuan et al. (2022) developed a dual-community model including the asymptomatic-hospitalised-recovery-pathogen SEI (SEI/AHR-P) model for construction workers and the asymptomatic-hospitalised-recovery SEI (SEI/AHR) model for their close contacts, to access the effectiveness of nonpharmaceutical interventions and vaccination. It is without a doubt that a macro perspective of COVID-19's impact on the construction industry can be derived based on their models, however, the overall conclusions are less valuable when it comes to the micro level (i.e., a specific construction site) and thus it is difficult for site management to use such conclusions for making optimal decisions on the application of protective measures. The main reason is that the above research focused on the global behaviours (e.g., the reproduction number R_0 , hospitalisation rate.) of the epidemic but neglected local factors (e.g., human behaviour and layout of construction sites) that would significantly influence COVID-19 transmission in construction sites.

In order to accurately evaluate COVID-19 transmission risk at the micro level (e.g., construction site in this study), there is an urgent need for a comprehensive understanding of how detailed human behaviours would impact the COVID-19 infection profile. Agent-based modelling, a computational model that aims at simulating the individual (agent) autonomous behaviours and quantifying the impact of those behaviours on system outcomes, has been widely used for investigating COVID-19 transmission dynamics under a microscope. For instance, Araya has conducted extensive research on COVID-19 transmission risk on construction sites using ABM (Araya, 2021a, 2021b, 2022). Araya (2021a) first developed an ABM to explore the potential impact of COVID-19 on construction workers where the activities were classified as a low-medium-high risk under the context of COVID-19 and the simulation time was set as three months. Scenarios were set up based on the ratio of the activity risk level. The study indicated a 30% – 90% reduction in the workforce due to COVID-19. In a follow-up research, Araya employed ABM for assessing safety control measures including adapting work shifts (Araya, 2021b) and employing multi-skilled workers (Araya, 2022). However, the research oversimplified the characteristic of COVID-19 by simply categorising COVID-19 into infected and not infected, which ignored the complex nature of COVID-19. As a modification of Araya's work, Gerami Seresht (Gerami Seresht, 2022) introduced a stochastic multi-agent framework using ABM and Monte Carlo simulation, "SEIR" model was also applied to simulate the spread of COVID-19 in a residential building project case study, as well as to assess the effectiveness of face-covering for preventing disease transmission. Great contributions have been made to the existing body of knowledge; however, it is noticed that the layout of a construction site which is the primary factor that determines human behaviours (e.g., movement) was

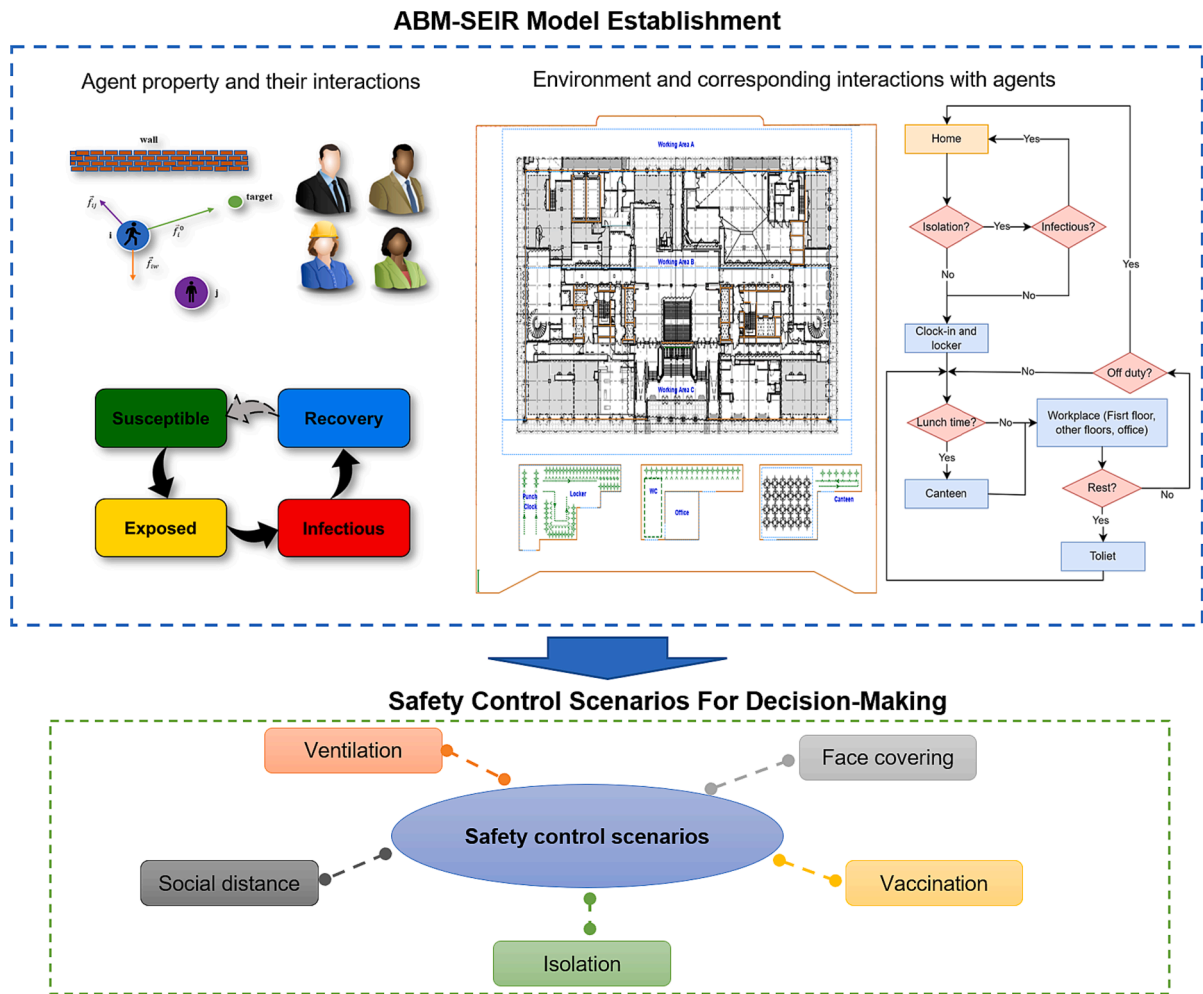

Fig. 1. Overview of the ABM-SEIR model.

neglected within most of the existing research. Additionally, in terms of the epidemiology of COVID-19, it is reported that the impact of COVID-19 varies for different populations (Mathur, 2021). The reflection of such heterogeneity was also absent within most of the existing research contributions.

With regards to safety control measures (SCM), World Health Organisation (WHO) has suggested a couple of advice to the public for combating COVID-19, including getting vaccinated, wearing of face covering, increasing the amount of natural ventilation to indoor environment, self-isolation if feeling unwell/exhibiting symptoms of the diseases, etc. (World Health Organisation, 2023), which has been widely adopted by governments globally. The effectiveness of SCM has also

been widely examined by scholars. For instance, Nanduri, et al. (Nanduri, 2021) confirmed that the effectiveness of Pfizer and Moderna vaccines against infection was 53.1% based on 85,593 weekly reports. In terms of wearing face coverings, Chu et al. (Chu et al., 2020) revealed a 17.4% change in viral infection rates without face coverings when compared to 3.1% with face coverings. The infection probability with varying levels of ventilation within confined spaces is also well documented in (Dai and Zhao, 2020). Despite the scholarly endeavours with regards to the effectiveness of the above SCMs, it is noticed that existing research only focused on 1–2 measures and there is no research that systematically examines the effectiveness of different combinations of SCMs on a construction site as addressed in this study.

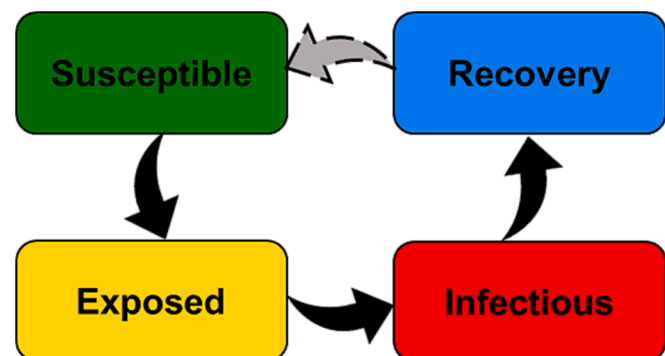

Fig. 2. SEIR model flow.

3. Methodology

An Agent-based SEIR model (ABM-SEIR model) was developed to investigate COVID-19 transmission risk on a construction site, as well as to evaluate the effectiveness of corresponding SCM in preventing the spread of COVID-19, so as to provide scientific evidence for stakeholders or policymakers during decision-making. The integrated ABM-SEIR model approach is illustrated in Fig. 1 which comprises an ABM-SEIR model establishment and safety control scenarios. The proposed ABM-SEIR model was constructed using AnyLogic platform (version 8.7.10). It is a multi-agent modelling software to create a professional virtual prototyping environment and simulate discrete, continuous, and mixed behaviours of complex systems. The user interface of the proposed ABM-SEIR model for simulating COVID-19 transmission risk on a construction

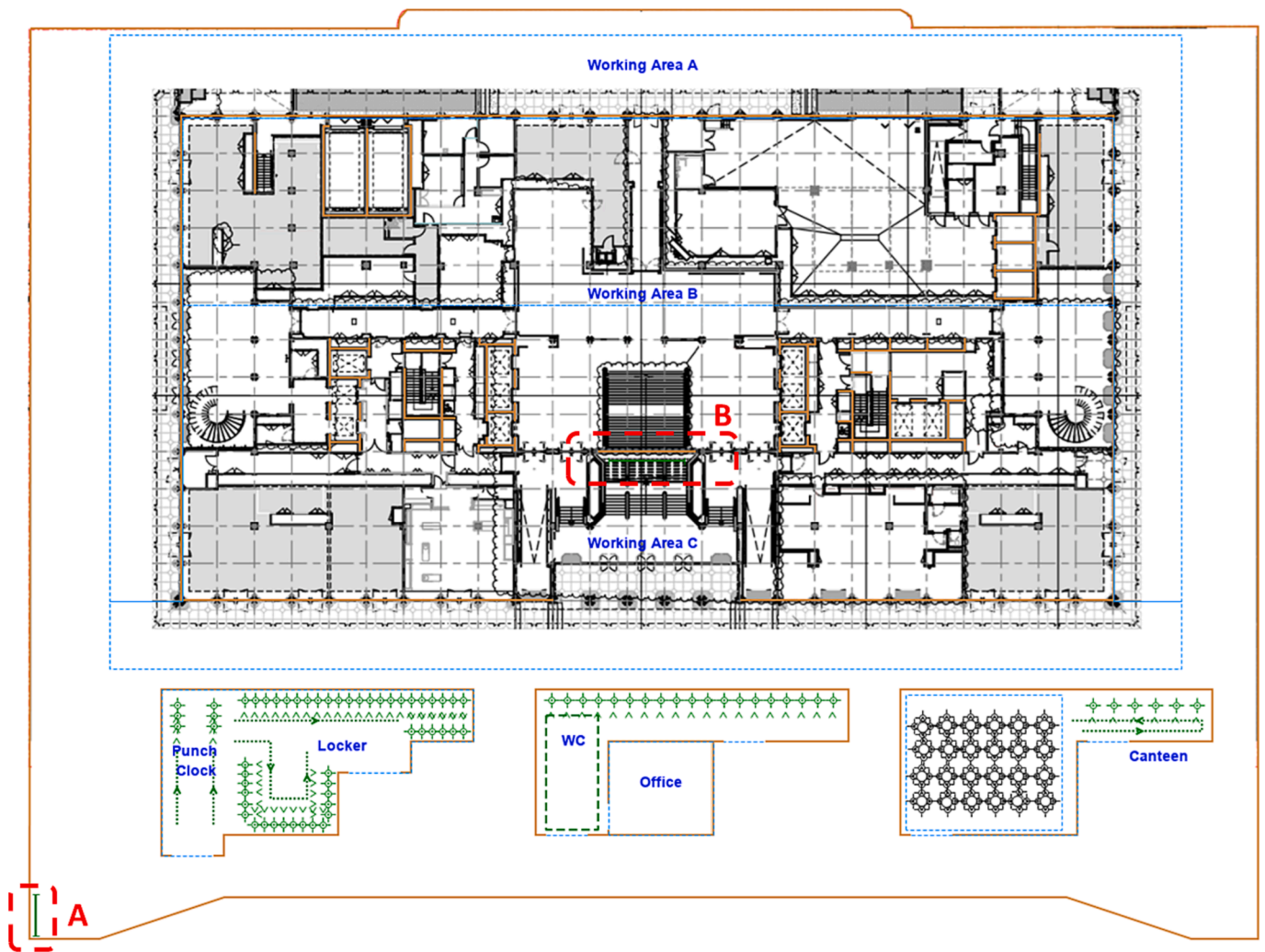

Fig. 3. Construction site layout in model.

site is presented in Appendix 2. Additionally, an SCM panel was integrated into the interface to allow users to pre-set the SCM scenario via sliding bars to indicate the expected compliance rates of each SCMs.

3.1. Overview of ABM-SEIR model

SEIR model is a widely used epidemic model for depicting the transmission dynamics of infectious diseases (e.g., influenza A and COVID-19) (Mwalili et al., 2020). It is a mathematical modelling technique in which the population is assigned to states of Susceptible, Exposed, Infectious, or Recovery. The flow patterns of how people progress across the different stages are indicated in the order of the labels SEIR, as shown in Fig. 2. Consequently, people are initially at the susceptible (S) stage which designates the fraction of a population that can contract the disease. This stage is then followed by being exposed (E), representing the fraction of the exposed (E) population that has become infected but is still not infectious. The infectious (I) stage accounts for a fraction of the population that is capable of spreading the disease. Finally, the Recovery (R) stage denotes the fraction of the population that has recovered from the disease. Many studies within the existing body of knowledge have developed or adapted the SEIR model to estimate the reproductive number, understand the pattern of epidemic spread, and predict the number and duration of a pandemic (Bakker and Halford, 1988; Ferguson and Bailey, 1992; Jefferson et al., 2008; Huang et al., 2020; Prem et al., 2020; Ribeiro et al., 2020; Bossert et al., 2021). However, those equation-based models are often used for

large populations (e.g., countries and cities) and have the drawbacks of not being able to adequately incorporate population heterogeneity (e.g., age, gender and vaccination status), compliance with different protective measures (e.g., social distancing and face covering) and variation of contact duration, which are essential for estimating the spread of COVID-19.

ABM is a computer simulation technique that allows the creation, disappearance, and movement of a finite collection of interactive individuals or agents with unique attributes regarding spatial location, physiological traits, and/or social behaviours (Zhang et al., 2021). ABM functions on a bottom-up basis, with population-level behaviour emerging from the interactions between autonomous individuals and their environment. The key advantages of ABMs are that they can stimulate complex social interactions, individual and collective behavioural adaptation, and different intervention measures (Zhang et al., 2022). In addition, the agents' interactions and outputs of those interactions can be easily adjusted and visualised by users.

In order to simulate COVID-19 transmission of a small population, this study established an ABM-SEIR model as shown in Fig. 1 that enables individual agents to migrate across the different transmission stages of COVID-19, whereby each individual is modelled according to their own "SEIR" state in terms of severity and time spent in that state. Furthermore, the model simulates how individuals interact with each other (i.e., contact duration and frequency), based on work schedules and social distancing rules.

Table 1
Properties of agents.

Properties of Agents	Distribution	Value
Total number	–	100
Age (Youngest, Mode, Oldest)	Triangular	(20, 34, 60)
Gender (Male%: Female%)	Bernoulli	(95: 5)
Household size (Min, Max, Mean, Shift, Stretch)	Poisson (truncated)	(1, 10, 3, 0, 1)
Number of children in family (Min, Mode, Max)	Triangular	(0, 0, 10)
Infection status (Infected%: Not infected before%)	Bernoulli	(5: 95)
Vaccination (None%: 1 dose%: 2 doses%: 3 doses%)	Discrete probability	(27: 5: 31: 37)
Face covering (Wearing%: Not wearing%)	Bernoulli	(73: 27)

3.2. Model components and their interactions

The integrated ABM-SEIR model includes 4 elements: 1) agent, 2) environment, 3) interactions between agents, and 4) interactions between agents and the environment.

3.2.1. Agents

Agents represent the construction workers working on site. Based on the previous studies (Madewell et al., 2020; Scobie et al., 2021), worker attributes such as age, gender, household size and number of children within each agent's family were incorporated into the model, owing to their established effects on COVID-19 transmission risk.

3.2.2. Environment

The environment is a construction site that includes the main building site (i.e., ground floor) and welfare facilities (e.g., toilets, meeting rooms and clock rooms) outside of the main building site (as shown in Fig. 3). The rationale behind selecting the ground floor and welfare facilities as the primary focus for this model is based on the fact that all workers on the construction site must pass through the ground floor to reach their respective workplaces on other floors, as well as need to use the welfare facilities at some point during their shifts, thereby making such areas the highest points of interface.

3.2.3. Interactions between agents

COVID-19 transmission dynamic was simulated through the interactions between agents. In particular, there are three main actions that could affect the transmission risks: 1) maintaining social distancing (Chu et al., 2020), 2) wearing face coverings (Luo et al., 2023), and 3) getting vaccinated (Mikulčić et al., 2021). COVID-19 vaccines currently approved for use in the UK are Moderna, Oxford/AstraZeneca, Pfizer/BioNTech, Janssen (also known as Johnson & Johnson), and Novavax vaccines. Research (Nanduri, 2021) has shown that vaccines help reduce the risk of getting seriously ill or dying from COVID-19, the risk of catching or spreading COVID-19, and protect against COVID-19 variants. Different types of vaccines have similar effectiveness, but the different number of doses (i.e., 1 dose, 2 doses, a booster dose) have a great impact on the vaccines' effectiveness (Lopez Bernal, 2021; Nanduri, 2021; Thompson, 2021; Lauring, et al., 2022; Scobie, et al., 2021a).

3.2.4. Interactions between the agents and the environment

Agents move around different parts of the construction site, based on their work schedules. Site areas (i.e., specific working zones and welfare facilities) are very prone to clustering, which brings favourable conditions for spreading the virus. Therefore, site areas need to be carefully considered in the model. Isolation strategies have also been considered in the model. According to previous studies (Luo et al., 2021; Chen et al., 2023), ventilation affects the spread of disease to a large extent. Therefore, the availability and unavailability of ventilation on the site were also mimicked in the model.

Table 2
Duration at work locations.

Work Locations	Distribution	Duration (Minutes)
Working Areas	Uniform	30–60
Office	Uniform	30–60
Punch Clock	Uniform	1–3
Locker	Uniform	2–15
WC	Uniform	1–20
Canteen (ordering and queueing)	Uniform	2–10
Canteen (eating and drinking)	Uniform	20–40

3.3. Model development and data collection

3.3.1. Defining the properties of the agent

To define the agent properties used in the model, an online survey was deployed at one of UK's large construction sites in February 2022, with a return of 175 valid responses from a population of 250 workers. The outcomes of the responses were then used to update the values of the agent properties within the model. Table 1 summarises the agent properties, including the total number of agents, age, gender, household size and number of children within the families of individual agents, vaccination status, previous COVID-19 infection status and the use of face coverings.

3.3.2. Definition of the simulation environment

The construction site information considered for this study include the site size, site layout, and ventilation state. The representation of the construction site in the model (i.e., ground floor of the main building and 3-floor welfare building) is shown in Fig. 3. The size of the site is about 110 m × 85 m and as shown in Fig. 3, the solid brown line represents the walls, while the blue dotted line represents the specific working areas. The solid green line represents the entry and exit points of the construction site (i.e., box A) and from other floors in the main building (i.e., box B). Light green marks represent specific functional modules. The L-shaped welfare building has three floors, and to simplify its representation, three identical blocks are displayed at the front of the site. Because the building is still under construction, only the exterior and load-bearing walls inside the building were modelled.

The ground floor of the main building was divided into three working areas, named A, B and C according to the work schedule provided by the contractor. Several site areas were placed on the three floors of the L-shaped welfare building, including a punch clock, locker, office, toilets, and canteen.

The model considers several different ventilation conditions, including outdoor, indoor with ventilation and indoor without ventilation. The parameter named weight for ventilation state is introduced in the model to modify the virus transmission ability under different ventilation environments.

3.3.3. Defining the interaction rules

The interaction rules between agents and environment were guided by the process-centric model related to the work schedule, the social force model embed in ABM, and the isolation strategies. COVID-19 transmission behaviour is the only interaction between agents and was governed by the agents' individual SEIR model.

A 4-week work schedule was obtained from the participating contractors for February 2022, which guided the development of a process-centric model that simulates the logic of workers' behaviour and movements, as shown in Table 2. In addition to the work schedule provided by the contractor, some reasonable assumptions have been made based on the general working conditions across most sectors in the UK. For instance, the proposed model depicts that worker is onsite between 9 am to 5 pm every day and take their lunch breaks from 12 pm to 1 pm. The work schedule also indicates 100 workers on the ground floor (including workers within the interior and exterior site locations). More specifically, there were 10 workers each in areas A and B; 9 in area C; 5

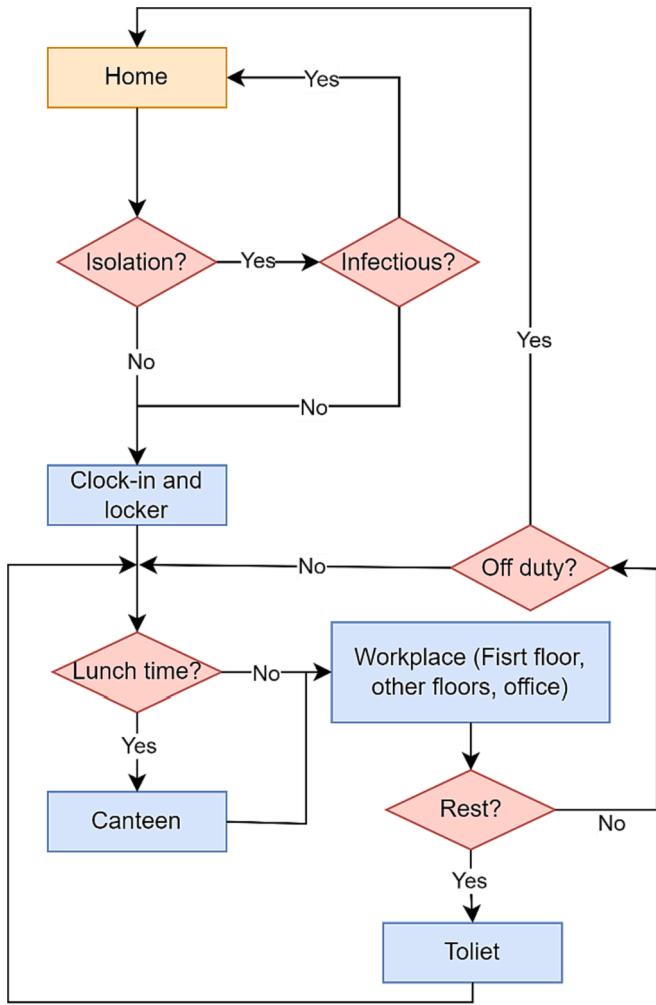

Fig. 4. Logic flow chart of workers' actions and movements on site.

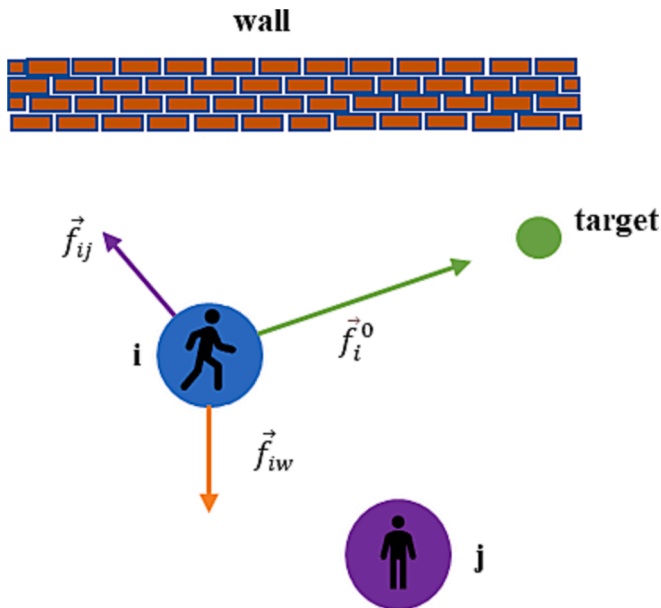

Fig. 5. Diagram of the social force model.

in the office areas. The remaining 66 workers were engaged in different activities across the remaining floors of the building. Every worker was assumed to have a 25% chance of needing a 10-minute comfort break after every 2 h of work. The summary of time spent within each site area is shown in Table 2, while the logic flow chart of workers' actions and movements on site is shown in Fig. 4.

The social force model (SFM) described below was incorporated in ABM to guide agents' movement against barriers such as walls and other people, as well as to reach goal locations in the shortest feasible distances. Although the original literature (Araya, 2022) around SFMs is based on the term pedestrians, The study has replaced pedestrians with agents in this study for better inclusivity and uniformity. The concept of SFMs was first proposed by Helbing and Molnar (Helbing and Molnar, 1995) to represent the motion of agents. According to SFM, the movement of agents may be shown as though they are subject to certain "social forces" that are not necessarily brought on by their environs, but rather, are an expression of the internal urges of the agents to carry out particular acts connected to their motions throughout designated zones. The physical force vectors that drive such movements are referred to as social forces which consist of three force vectors including the driving force \vec{f}_i^0 , inter-agent force \vec{f}_{ij} and boundary force \vec{f}_{iw} (Araya, 2022). According to Newton's second law of motion, the corresponding expression of each agent i is shown in Equation (1) and the diagram is shown in Fig. 5:

$$m_i \frac{d\vec{v}_i(t)}{dt} = \vec{f}_i^0 + \sum_{j(\neq i)} \vec{f}_{ij} + \sum_w \vec{f}_{iw} \quad (1)$$

Where m_i is the mass of agent i , and $\vec{v}_i(t)$ is the walking velocity at time step t .

a) Driving force.

The driving force \vec{f}_i^0 indicates the intention of the agent to reach a target, based on the desired speed v_i^0 and desired direction \vec{e}_i^0 . The driving force is represented in Equation (2):

$$\vec{f}_i^0 = m_i \frac{v_i^0(t) \vec{e}_i^0 - \vec{v}_i(t)}{\tau_i}, \quad (2)$$

where $\vec{v}_i(t)$ is the agent velocity at time step t , and τ_i is a characteristic time scale that reflects the reaction time.

b) Inter-agent force.

Inter-agent force is comprised of socio-psychological force \vec{f}_{ij}^s and physical force \vec{f}_{ij}^p . In contrast to the physical force, which shows actual interaction between agents in crowded contexts, the socio-psychological force reflects the psychological inclination of two actors to maintain a particular safe distance from one another. The corresponding expressions are shown in Equations (3) and (4):

$$\vec{f}_{ij}^s = A_i \exp\left(\frac{r_{ij} - d_{ij}}{B_i}\right) \vec{n}_{ij}, \quad (3)$$

$$\vec{f}_{ij}^p = k g(r_{ij} - d_{ij}) \vec{n}_{ij} + \kappa g(r_{ij} - d_{ij}) \Delta v_{ji}^t \vec{t}_{ij}, \quad (4)$$

where A_i , B_i , k , κ are constant parameters. \vec{n}_{ij} is the unit vector pointing from agent j to agent i . \vec{t}_{ij} is the unit tangential vector and orthogonal to \vec{n}_{ij} and $\Delta v_{ji}^t = (v_j - v_i) \cdot \vec{t}_{ij}$ is the tangential velocity difference.

c) Boundary force.

The boundary force is similar to the physical force of inter-agent and the mathematical expression is shown in Equation (5)

$$\vec{f}_{iw} = A_i \exp\left(\frac{r_i - d_{iw}}{B_i}\right) \vec{n}_{iw} + k g(r_i - d_{iw}) \vec{n}_{iw} + \kappa g(r_i - d_{iw}) \Delta v_{wi}^t \vec{t}_{iw}, \quad (5)$$

where d_{iw} is the distance between the centre of agent i and the surface

Table 3
Parameters of the social force model (Qiao and Yunusa-Kaltungo, 2023).

Parameter	Symbol	Value
Agent radius	r	0.25 m
Strength of social repulsive force	A	2000 N
Characteristic distance of the social repulsive force	B	0.08 m
Coefficient of sliding friction	k	240000 kg m ⁻¹ s ⁻¹
Body compression coefficient	κ	120000 kg s ⁻²
Agent reaction time	τ	0.5 s

Table 4
Properties of SEIR model for COVID-19 transmission.

Parameter	Description	Initial value	Range	Relevant Reference
β_0	Local infection rate	0.0568		(UK Office for National Statistics, 2020)
a_1^i	Weight for age	1	0.37 – 1	(Madewell et al., 2020)
a_2^i	Weight for gender	1	1 – 1.2	(Madewell et al., 2020)
a_3^i	Weight for household size	1	1 – 2.23	(Madewell et al., 2020)
a_4^i	Weight for number of children	1	1 – 2.58	(Madewell et al., 2020)
a_5^i	Weight for vaccination status	1	1 for not vaccinated, 0.67 for 1 dose, 0.15 for 2 doses, 0.06 for 3 doses	(Lopez Bernal, 2021; Nanduri, 2021; Lauring, et al., 2022)
a_6^i	Weight for infected or not before	1	0.8 – 0.93 for infected, 1 for not infected before	(Chu et al., 2020)
a_7^i	Weight for face covering	1	0.174 for face covering, 1 for non-face covering	(Chu et al., 2020)
β_1	Workplace transmitting rate per contact	0.5	0 and 1	(Killingley et al., 2022)
a_8	Weight for ventilation state	0.29	0.001 – 1	(Dai and Zhao, 2020; Burridge et al., 2021)
σ	Incubation period	4 days	4 days – 6 days	(Kang et al., 2021)
γ	Symptom duration	10 days	8 days – 24 days	(Kang et al., 2021)
ξ	Immune duration	3 months	3 months – 13 months	(Kim et al., 2022)

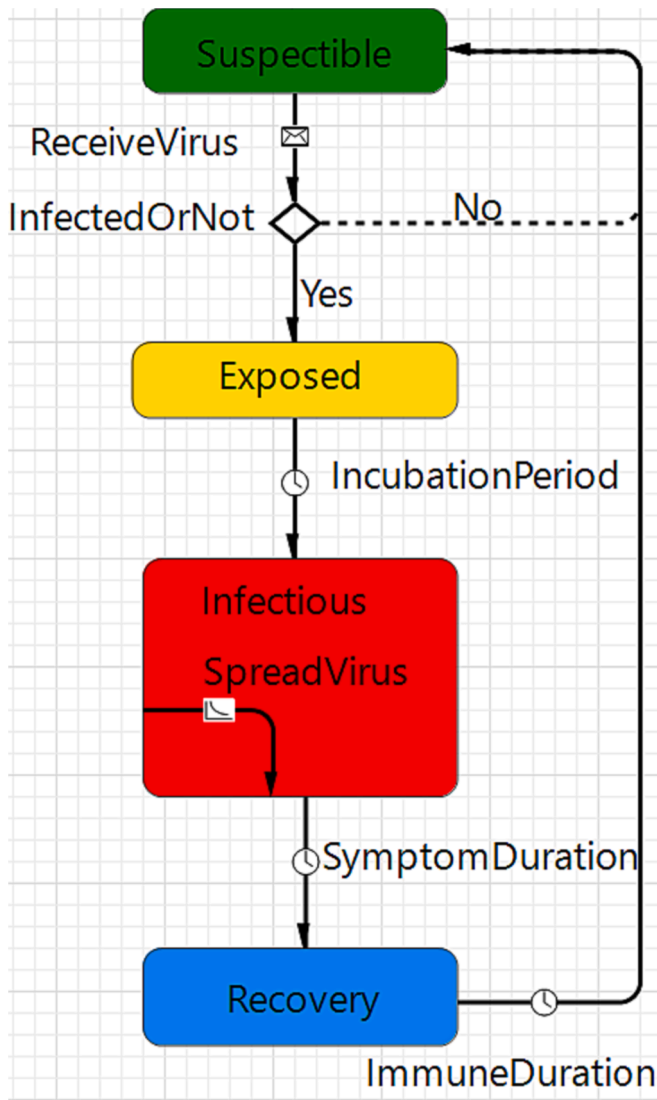

Fig. 6. The state chart of SEIR model.

of walls.

The specific parameters of the SFM considered in this study are specified in Table 3.

Isolation strategy is another protective control measure applied in the integrated model. The isolation strategy within this model places a checker point before a worker goes to work daily. If a worker is adjudged to be in an infectious state, based on the outcomes of the individual SEIR model calculations before the commencement of the day, then such an agent must remain isolated within their home for 14 days. Those workers who enter the infectious state from the exposed state in the middle of their work will continue to work on site until the next day, to simulate the real-life self-examination strategy of workers before the

next day’s work.

The SEIR model for individual agents was developed based on specific attributes, especially the duration of interactions and workplace protective measures. Hence, the completion of the SEIR stages by each agent is bound to be different as further clarified by the following explanations:

The susceptible state consists of agents who may become infected. The exposed state is however characterised by agents that have received a certain load of the pathogen but not yet infectious or symptomatic. On the contrary, the infectious agents are those currently afflicted with the disease and can infect other agents; while agents in the Recovery stage have overcome the disease and gained some levels of immunity. The modified SEIR model is shown in Fig. 6, which is also a representation of the transitions between different states for an individual (S → E → I → R).

S → E: The state transition from susceptible to exposed occurs when a susceptible agent comes into close contact with an infectious agent. Each infectious agent has an infection range, and if another agent comes within their infection range, then they are considered to be in close contact.

E → I: The state transition from exposed to infectious upon the completion of the incubation period σ of the disease, starting from the instance of exposure.

I → R: The state transition from infectious to recovery upon the completion of the symptom duration γ .

R → S: The state transition from recovery to susceptible happens upon the completion of the immune duration ξ .

The state transition from S to E is considered based on the transmission probability β . Hence, the probability of disease transmission β_{ij} between agents i and j is influenced by agent properties, behavioural

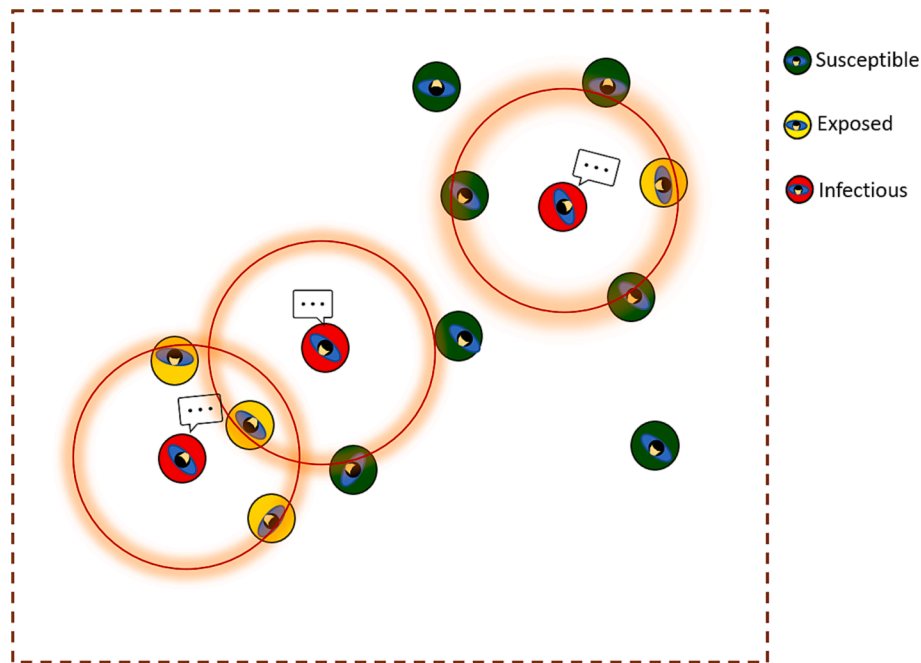

Fig. 7. COVID-19 transmission mechanism.

attributes, and environmental attributes represented by Equation (6)

$$\beta_{ij} = \beta_0 \prod_{n=1}^6 a_n^i + \beta_1 \prod_{n=5}^7 a_n^i a_8 \quad (6)$$

The equation of transmission probability of each contact is comprised of two components - agent background and close contact. Agent background describes the vulnerability of an agent towards COVID-19 before entering the workplace. For instance, an elderly person from a high-density community, or a multi-children family without vaccination is regarded as a highly vulnerable agent. This is based on the notion that at every point in time, he/she will have a higher probability of getting infected when in close contact with an infectious agent for few seconds (Oliva and Favato, 2022). The UK Government defined a close contact as “a person who has been close to someone who has tested positive for COVID-19” (UK Health Security Agency, 2022), which is an indication of the probability of getting infected. The parameters of SEIR model and their associated descriptions, values, range, and relevant reference are listed in Table 4.

With specific reference to the model, agents at the infectious (I) stage will continue to send out one “infection” message per minute to all agents that are within a 2-meter radius. Although messages are sent to all the agents that are within close proximity of the infectious agent, however, only agents in the susceptible (S) state will react to the messages by transiting into the exposed (E) state, which is based on the probability of β that is estimated as depicted in Eq. (6). Fig. 7 illustrates examples of the transitions from S to E.

Notes: Fig. 7 only functions as an illustration and does not represent the exact truth of the situation. The red circles indicate the 2-meter radius of infectious agents, some susceptible agents within the circles may transit into exposed stage based on probability β . Some susceptible agents may remain healthy.

3.4. Safety control measures scenarios

In addition to simulating COVID-19 transmission risk on a construction site, evaluating the effectiveness of the various safety control measures is also an essential task of this study so as to provide scientific evidence for decision-making of COVID-19 control on construction sites. COVID-19 safety control measures scenario (CSCMS) can be mathe-

Table 5
Summary of 10 typical SCM scenarios.

Scenario	Description	[Fc, Sd, Va, Ve, I]
NSCM	A total lack of or no compliance with all SCMs	[0, 0, 0, 0, 0]
FcSCM	Full compliance with wearing face covering only	[1, 0, 0, 0, 0]
SdSCM	Full compliance with maintaining social distance only	[0, 1, 0, 0, 0]
VaSCM	Full compliance with taking vaccination only	[0, 0, 1, 0, 0]
VeSCM	Full compliance with keeping ventilation only	[0, 0, 0, 1, 0]
ISCM	Full compliance with following isolation rules only	[0, 0, 0, 0, 1]
MSCM (No isolation)	Moderate compliance with all SCMs except that there's no isolation	[0.5, 0.5, 0.5, 1, 0]
MSCM (No ventilation)	Moderate compliance with all SCMs except that there's no ventilation	[0.5, 0.5, 0.5, 0, 1]
FSCM (No isolation)	Full compliance with all SCMs except that there's no isolation	[1, 1, 1, 1, 0]
FSCM	Full compliance with all SCMs	[1, 1, 1, 1, 1]

matically expressed as:

$$CSCMS = SCMS(X, Y) \quad (7)$$

Where CSCMS is COVID-19 safety control measures scenario, SCM is the safety control measure, $X \in (1, 2, \dots, m)$ denotes m different safety control measures; $Y \in (0, 1)$ denotes the level of compliance with different safety control measures (0 means no compliance to 1 means full compliance).

For this study, 5 SCMs were considered, namely the percentage of wearing face covering (Fc), percentage of vaccination (Va), Social distance (SD), Ventilation (Ve) and Isolation (I). 3 levels of compliance ($Y = 0, 0.5, 1$) were considered for Fc, Va and SD. It should notice that 3 levels of compliance for social distance mean all agents will maintain 0, 1 and 2 m of social distance from each other, respectively; 2 levels of compliance ($Y = 0, 1$) were considered for Ve and I. A simulation of different compliance levels across all 5 SCMs was used to generate the 108 scenarios shown in Appendix 1. 10 typical scenarios were selected from the 108 scenarios to establish baseline conditions as listed in Table 5.

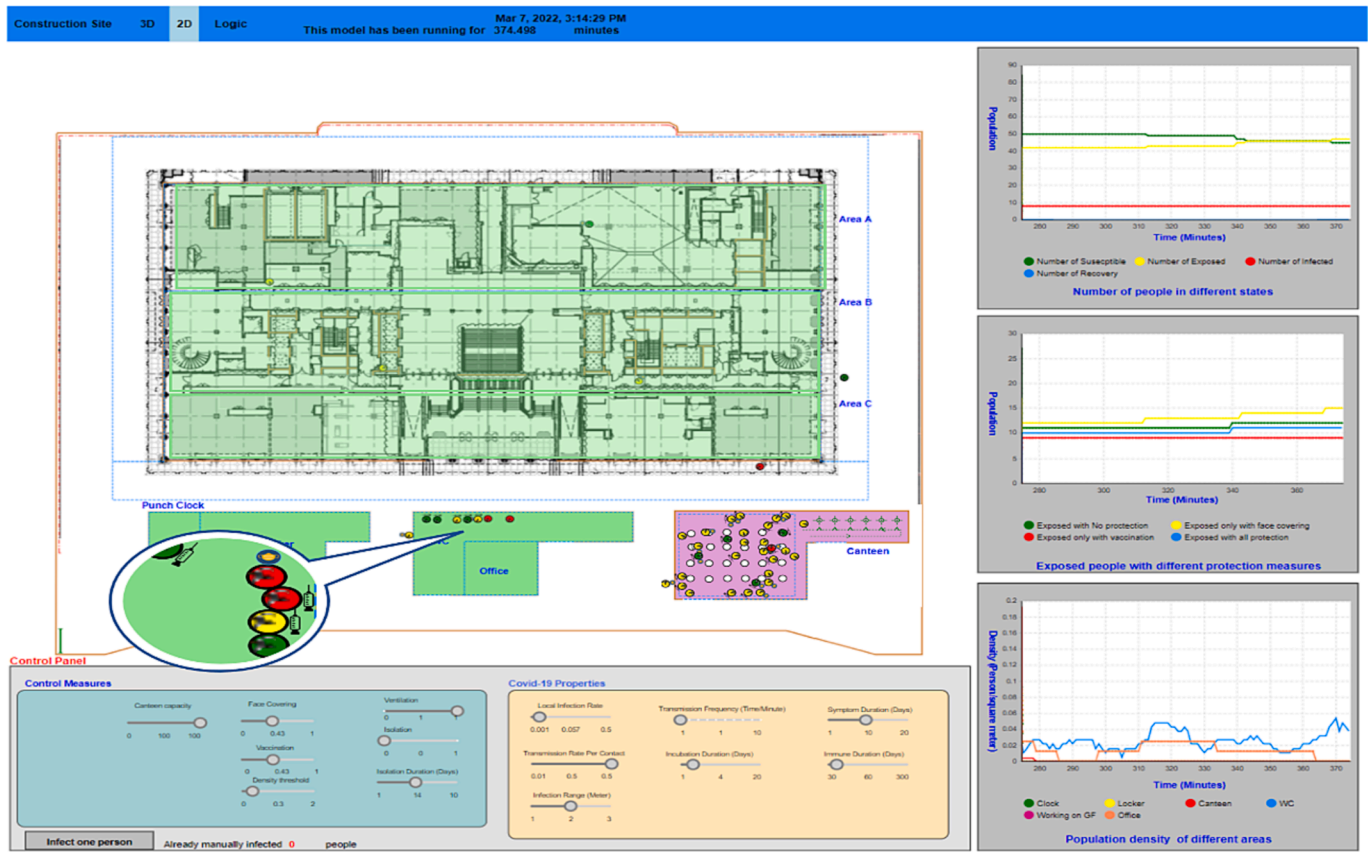

Fig. 8. The main 2D interface of the proposed model.

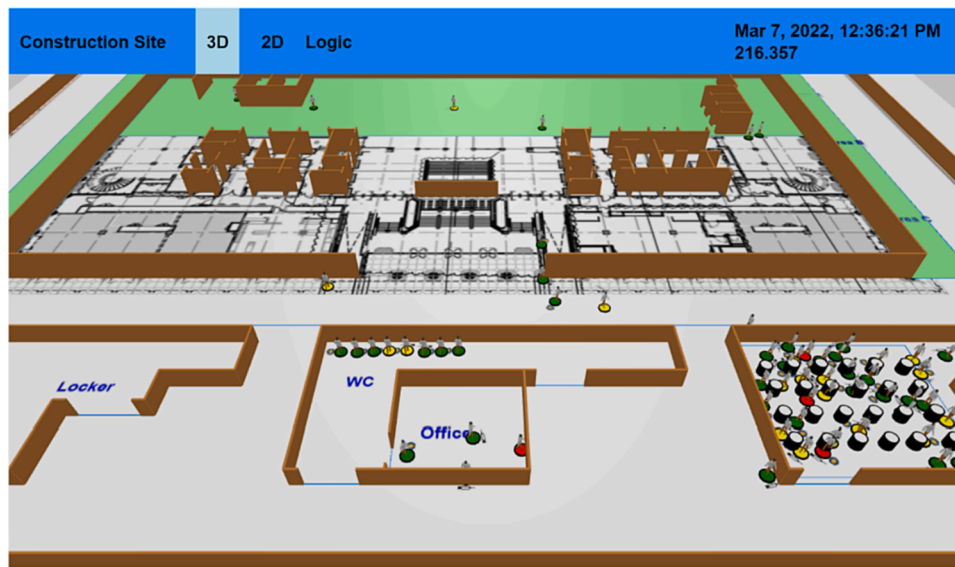

Fig. 9. 3D animation of the simulation.

NSCM represents no SCMs have been implemented on the construction site and COVID-19 is allowed to freely develop. NSCM is set as benchmark to compare the effectiveness of other CSCMS. FcSCM, SdSCM, VaSCM, VeSCM and ISCM represent the scenarios that only single SCM is implemented to measure the effectiveness of each SCM. Two moderate and two full compliance scenarios were also selected to evaluate the effectiveness of SCMs, based on half compliance or full compliance with all SCMs. Considering that it might be difficult for some

construction sites to maintain good ventilation or follow isolation rules, these two SCMs were accordingly ignored in MSCM and FSCM as shown in Table 5.

4. Results

Figs. 8-10 illustrate the graphical user interface (GUI) of the proposed ABM-SEIR model, which comprises a 2D model (Fig. 8), a 3D

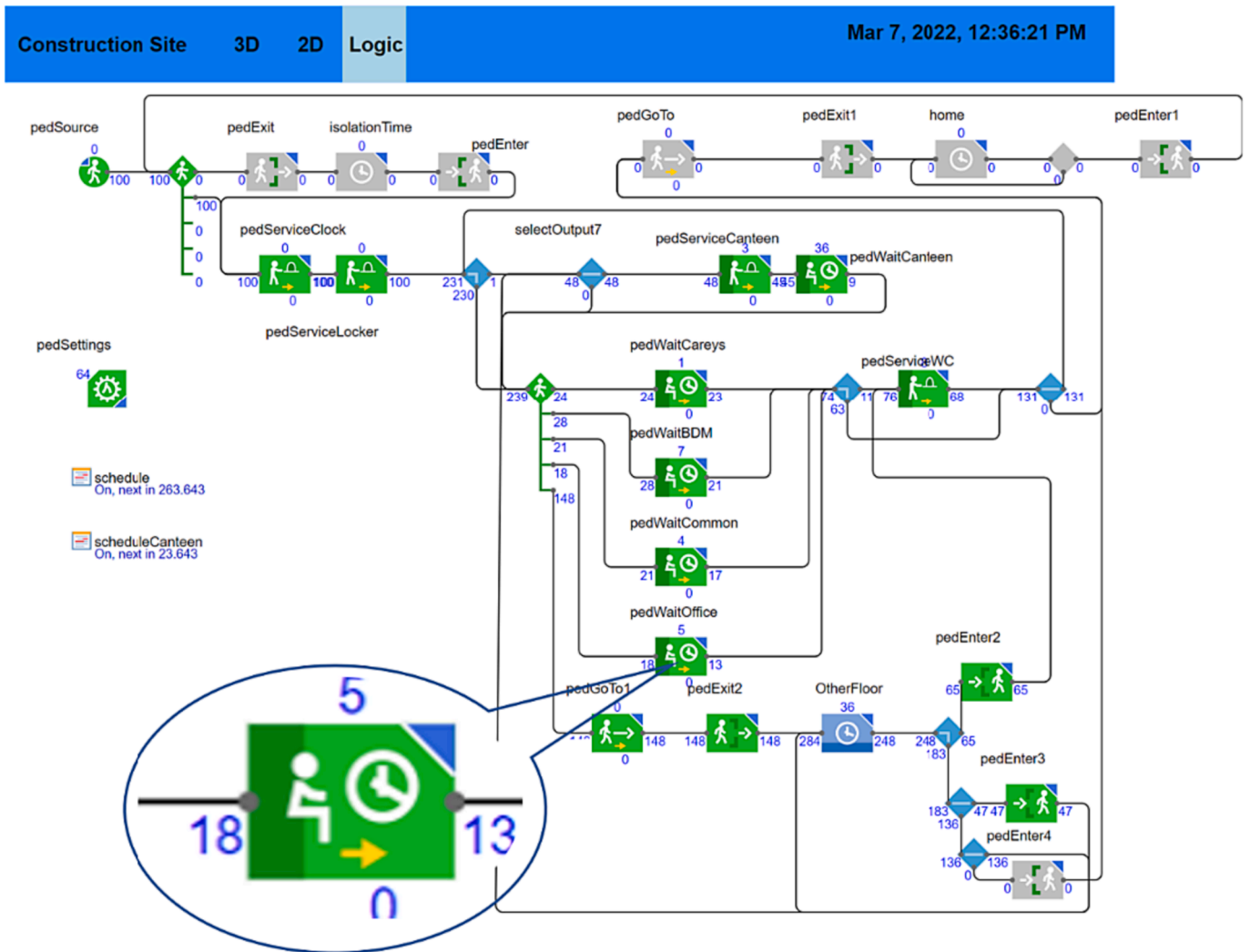

Fig. 10. the logic flow chart of the agent activity.

model (Fig. 9) and an activity flowchart (Fig. 10). A navigation bar at the top of each component allows users to switch between the 3 components. The model's total runtime was also integrated into the slide bar.

The CAD drawings of the construction site (i.e., ground floor layout) are situated at the top left-hand corner of the main interface as shown in Fig. 8. Agents with face covering or those vaccinated are distinguished by the corresponding icons as shown in the bubble. In order to adequately represent the high-risk areas, factors such as population density were also incorporated into the simulation process. Therefore, green and pink colours represent low-density/low-risk and high-density/high-risk areas or work zones within the model. The colour transition from green (i.e., low-density/low-risk) to pink (i.e., high-density/high-risk) occurs once density of the room exceeds the pre-set density threshold (i.e., 1 person/sqm (HOUSING DESIGN QUALITY AND STANDARDS SUPPLEMENTARY PLANNING GUIDANCE, 2019) and is adjustable slide bar in Control Measures penal in Fig. 8) and vice versa. The graphical outputs on the right-hand side are the number of agents in different SEIR states, the exposed agents based on different SCMs and the density of each room on the construction site, respectively. A control panel was embedded to allow users interact with the model while running. Besides the SCM panel, an additional panel that allows users to adjust the properties of COVID-19 to match those of other infectious diseases was incorporated, so as to maximise the generalisability of the proposed ABM-SEIR model.

The 3D animation of the simulation illustrated in Fig. 9 enables the

user to understand the interaction among individual agents and the interactions between the agents and their environment.

The logic flow chart in Fig. 10 not only indicates the agent's work schedule but also functions as a counter that provides indications of the level of traffic in each room. As shown in the bubble, each green block records the number of people entering and leaving individual areas or zones as well as recording the current population held by the areas or zones in real time.

For each of the scenarios, the modelling duration was set to 1 month (i.e., from 26th April to 26th May) so as to adequately account for all the stages of COVID-19. The time granularity was based on 1 min. Once it reaches 10 min (model virtual time), 10 messages were randomly sent to the agents on the construction site to transform their COVID-19 states from susceptible to infectious stage to simulate the breakout of COVID-19 on the construction site. The number of agents at the different COVID-19 states was then recorded on an hourly basis. In order to guarantee model robustness and representativeness of results, each safety control scenario was run 10 times and the average value of results was considered as the final outcome.

The number of agents at the different COVID-19 states, based on different SCM scenarios are presented in Figs. 11-14. As shown in Fig. 11, despite being unable to prevent the agent from getting infected, MSCM can postpone the time of susceptible agents from transforming to the exposed stage by 52 h compared with NSCM. When implementing FSCM, an obvious plateau was observed from 27th –29th April owing to

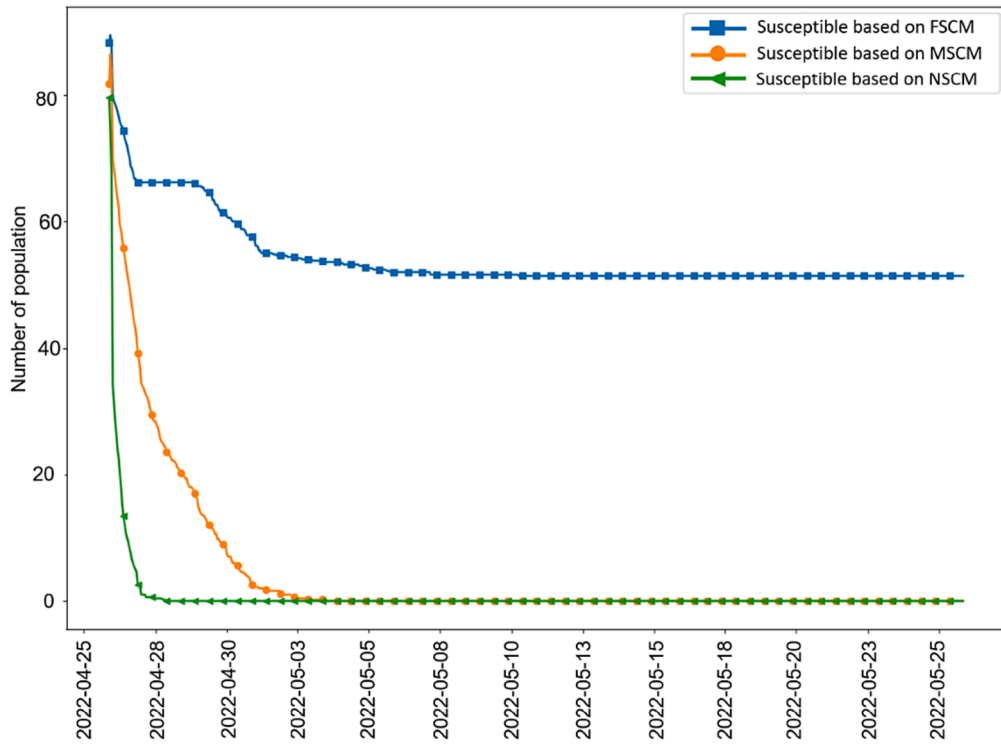

Fig. 11. The number of susceptible agents based on different SCM scenarios.

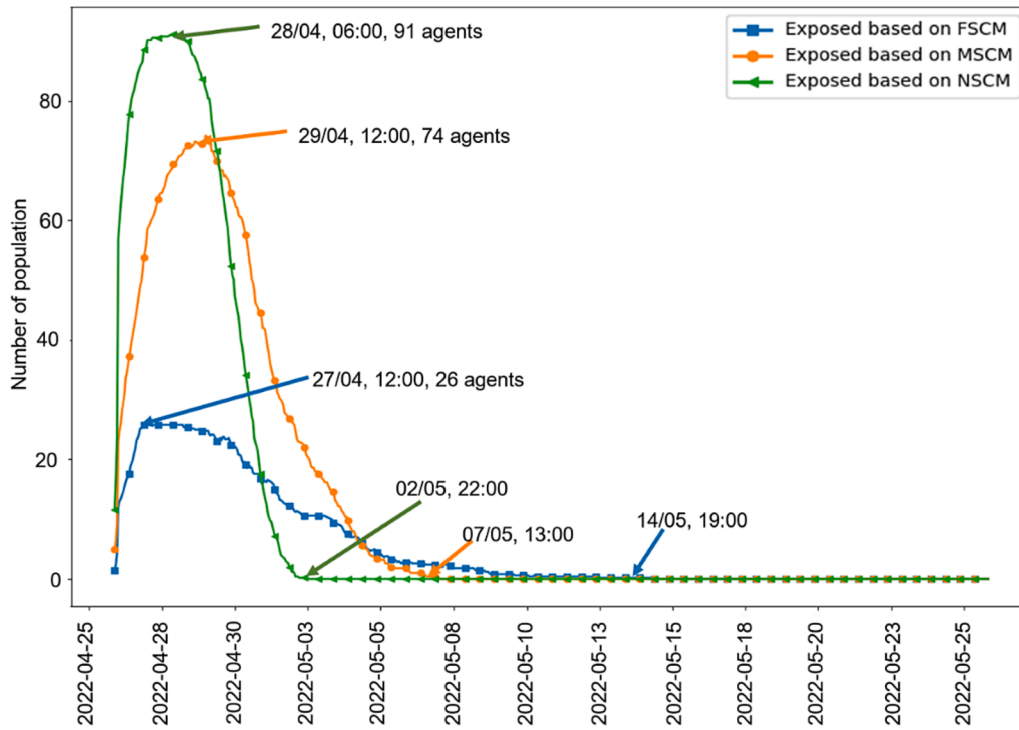

Fig. 12. The number of exposed agents based on different SCM scenarios.

the implementation of isolation strategies that ensured that all infectious agents were absent from the workplace. Meanwhile, it was noticed that around 50 agents remained in the susceptible state throughout the simulation process, which implies that the FSCM scenario is the most effective scenario to curtail the transmission of COVID-19 on a construction site.

In terms of the population of agents in the exposed state, Fig. 12

shows that MSCM reduced the peak of number of exposed agents by 17 and delayed the timing of the peak by 28 h, compared to the NSCM scenario. A significant reduction of the peak exposed population was found in the FSCM scenario of 26 agents. The relative flat curves in FSCM compare with the other two scenarios also further highlights the impact of FSCM in controlling and preventing the spread of COVID-19.

With regards to the population of agents in the infectious state,

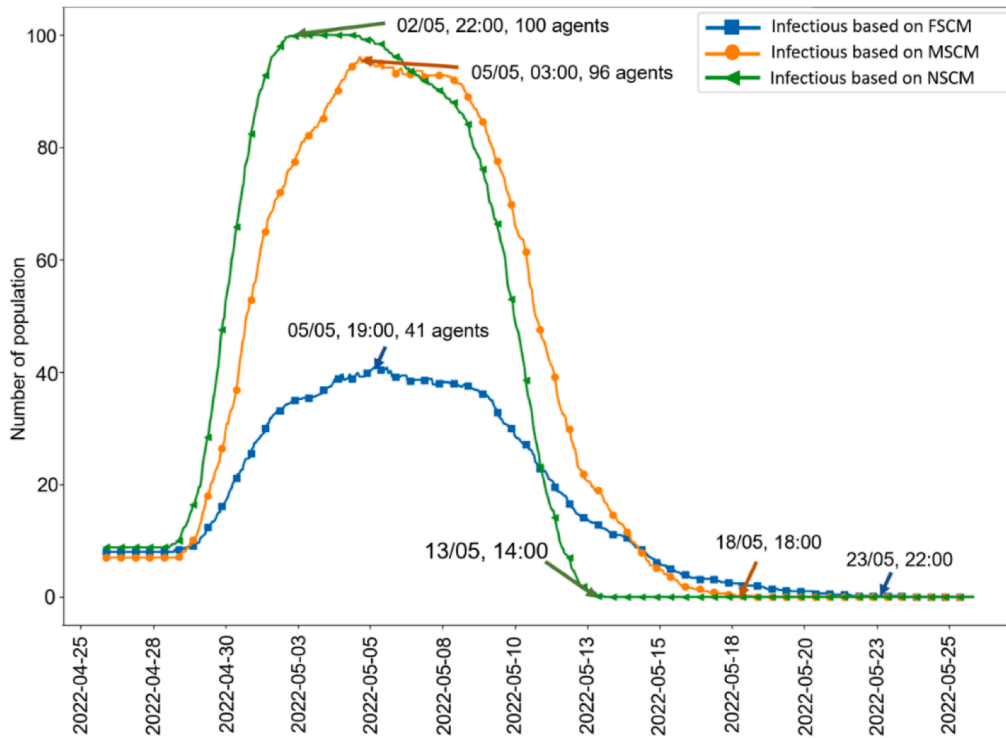

Fig. 13. The number of infectious agents based on different SCM scenarios.

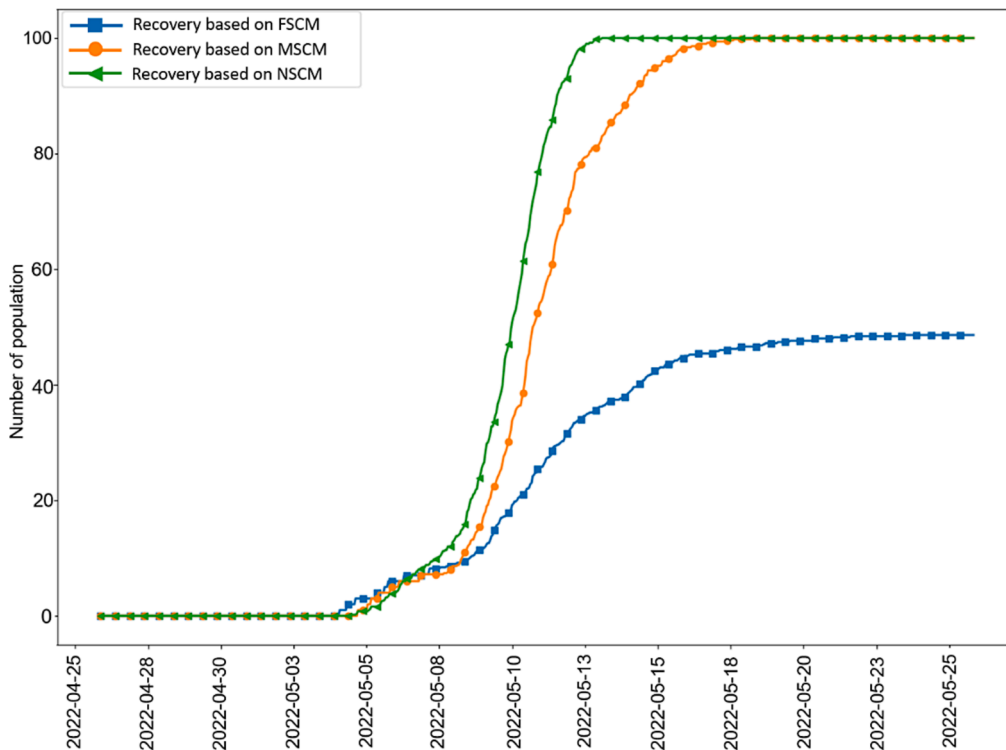

Fig. 14. The number of Recovery agents based on different SCM scenarios.

Fig. 13 depicted that despite the implementation of MSCM scenario, there was no tangible reduction in the peak number. It in fact alleviated the COVID-19 transmission to a certain extent by delaying the peak for 53 h, when compared with NSCM. Hence, the best results were still associated with the FSCM scenario, whereby the peak population was only 41 agents and the peak appeared 69 h later than that of NSCM.

Similarly, Fig. 14 illustrated that the results of recovery under the NSCM scenario had a sharp rise in the recovery rates of agents compared with other scenarios. This shows that NSCM was unable to prevent the spread of COVID-19 on the construction site.

In addition to the three baseline scenarios (i.e., NSCM, MSCM, and FSCM), Table 6, Figs. 15 and 16 summarise the results for all ten selected

Table 6
Summary (mean and standard deviation) of the effectiveness of different SCM scenario (unit of time: hours).

Scenario	[Fc, Sd, Va, Ve, I]	Peak value (Exposed)	Peak time (Exposed)	End time (Exposed)	Peak value (Infectious)	Peak time (Infectious)	End time (Infectious)	Final Recovery
NSCM	[0, 0, 0, 0, 0]	91.2 (0.45)	49	158	100 (0)	158	414	100 (0)
FcSCM	[1, 0, 0, 0, 0]	91 (0.72)	45	189	100 (0)	189	454	100 (0)
SdSCM	[0, 1, 0, 0, 0]	90 (0.45)	42	160	100 (0)	260	418	100 (0)
VaSCM	[0, 0, 1, 0, 0]	91.2 (0.83)	51	167	100 (0)	167	422	100 (0)
VeSCM	[0, 0, 0, 1, 0]	83.8 (4.66)	66	216	98.8 (1.30)	216	472	100 (0)
ISCM	[0, 0, 0, 0, 1]	88.4 (0.90)	24	241	99.2 (0.91)	193	482	99.8 (0.49)
MSCM (No isolation)	[0.5, 0.5, 0.5, 1, 0]	74.2 (2.96)	76	269	96 (2.13)	211	538	100 (0)
MSCM (No ventilation)	[0.5, 0.5 0.5, 0, 1]	63 (2.73)	57	494	84.6 (5.60)	220	696	90.8 (4.32)
FSCM (No isolation)	[1, 1, 1, 1, 0]	56.2 (4.48)	100	339	90.8 (2.28)	271	609	99.8 (0.45)
FSCM	[1, 1, 1, 1, 1]	25.8 (2.69)	24	443	41 (2.91)	227	662	48.6 (4.46)

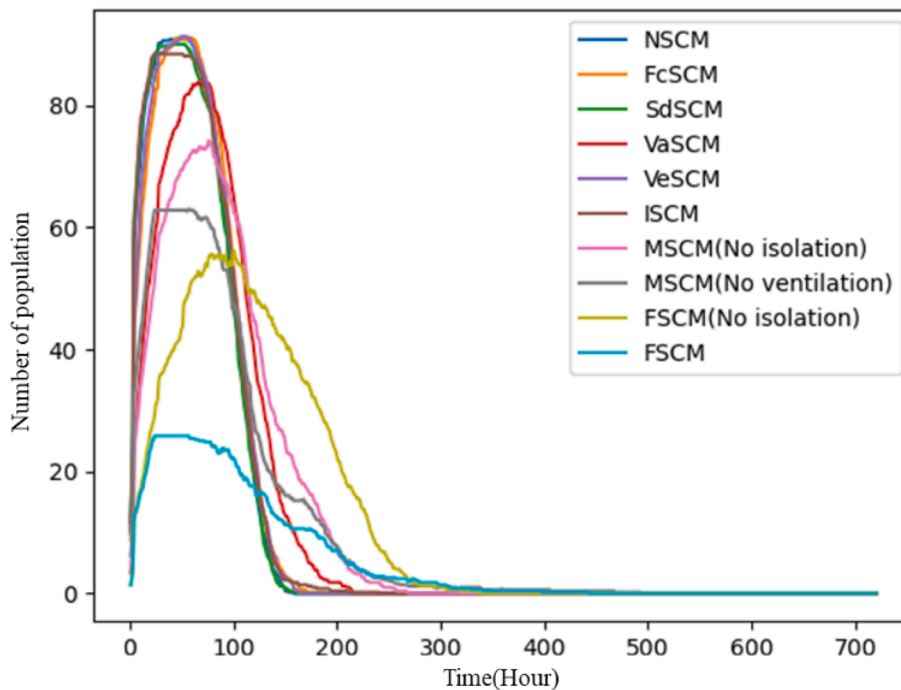

Fig. 15. The number of exposed agents based on the 10 SCM scenarios.

scenarios (results of all 108 scenarios are summarise in Appendix 3). It is noticed that for SCMs that were based on isolation on the construction site, an obvious plateau in terms of the exposed population was observed in Fig. 15. It is perhaps because once an agent transformed into an infectious state, he/she was not allowed to work and therefore the agent was not able to infect other agents.

When only considering single SCM, as shown in Fig. 15, ensuring all the agents are fully vaccinated was the most effective measure in reducing the peak value and time of the exposed population. All other single SCM failed to curb the transmission of the COVID-19. An obvious alleviation in COVID-19 transmission was found in MSCM (No isolation) and MSCM (No ventilation). However, it should be noticed that the former scenarios was more efficient. The main reason is that the objective of isolation is to exclude the COVID-19 virus from the construction site while the ventilation works by replacing the contaminated air with fresh air, which implies that the agents inside still have some chances of exposure to the COVID-19 virus.

Two fully compliant scenarios FSCM (No isolation) and FSCM were conducted, and the results implied that FSCM was the best of all 10 scenarios in preventing the COVID-19 transmission on construction sites. However, it may not always be achievable for stakeholders to

implement isolation at all times, especially industries such as construction which is labour-intensive and has needs for high-proximity working. FSCM (No isolation) showed a significant effectiveness in terms of keeping agents from the threats of COVID-19.

Furthermore, the average duration of each agent in a susceptible state and the number of messages each agent received before transforming into exposed state are two pivotal metrics for accessing COVID-19 transmission risk on construction sites and verifying the effectiveness of SCMs as can be seen in Fig. 17, Fig. 18 and Table 7. Without any SCM (NSCM), all the agents were exposed to an extremely dangerous environment and would transform into exposed state once they are exposed to the virus for an average of 6.3 h. The transmission was to a certain extent alleviated (up to 11.17 h) when fully compliant with single SCM, whereby vaccination was the most effective amongst the five SCMs. When it comes to MSCM, the time each agent spent in a susceptible state was 21.88 h (No ventilation) and 14.92 h (No isolation). The best result was achieved when fully compliant with all 5 SCMs (118.41 h was spent in the susceptible state), and a significant outperformance was observed for FSCM compared to full compliance without isolation. The results regarding isolation suggest that while the sole implementation of isolation did not lead to an improvement in preventing COVID-19 from

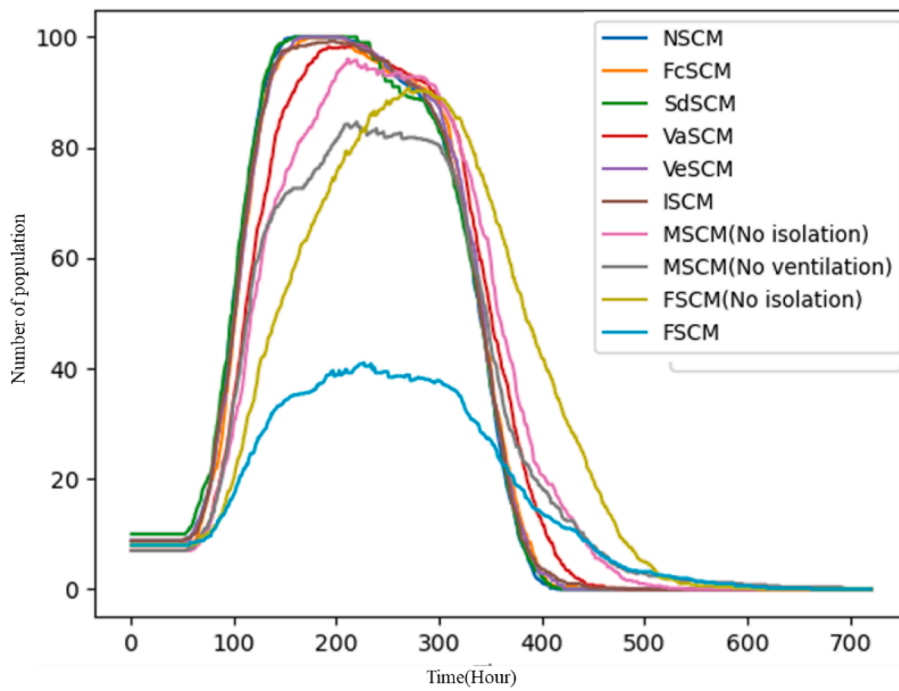

Fig. 16. The number of infectious agents based on the 10 SCM scenarios.

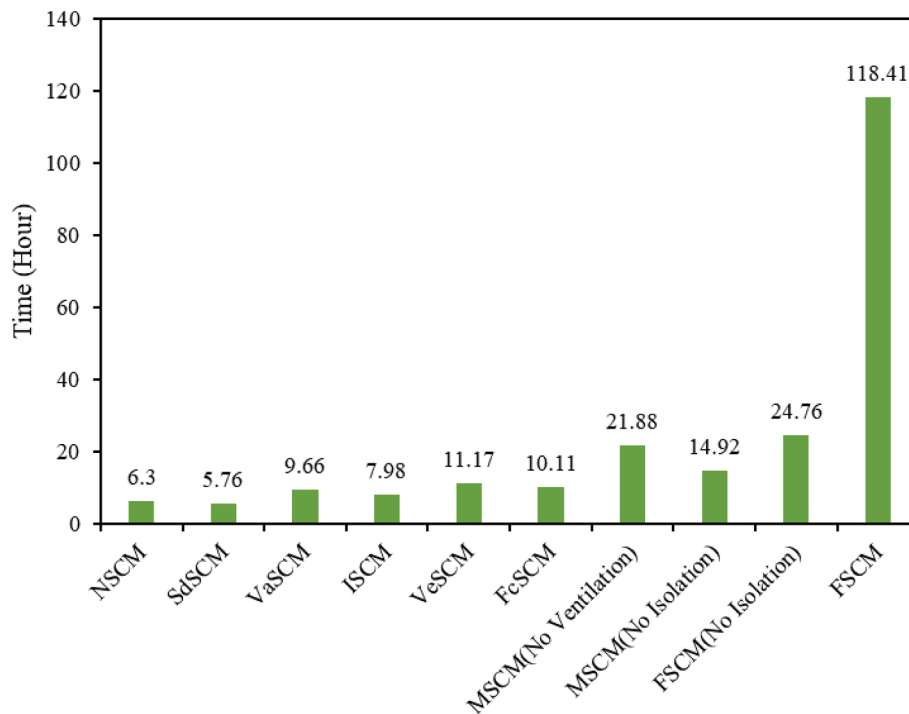

Fig. 17. Average duration of each agent remained in susceptible state.

spreading, a significant improvement (when compared with SCM scenarios without isolation) was achieved by combining isolation with other SCMs. Regarding the number of messages received (as shown in Fig. 18), implementing isolation worked by removing infectious agents from the workplace and reducing the number of messages. For SCMs (ventilation, face covering and vaccination), by increasing agents' resistance towards COVID-19, the agent was able to be exposed to COVID-19 more times without transforming into the exposed state. It is noticed that SdSCM did not work in preventing COVID-19 spreading,

which is perhaps due to the majority of contacts between agents occurring during lunch breaks, whereby social distance protocols are not entirely followed.

Additionally, an estimate of the amounts of contacts that occurred during the study period (one month) was obtained via the messages sent by the agents in each state as shown in Fig. 19 and Table 8. The results further strengthened the effectiveness of isolation as one of the most proficient means of preventing COVID-19 spread on the construction site. However, other SCMs did not depict any significant difference in

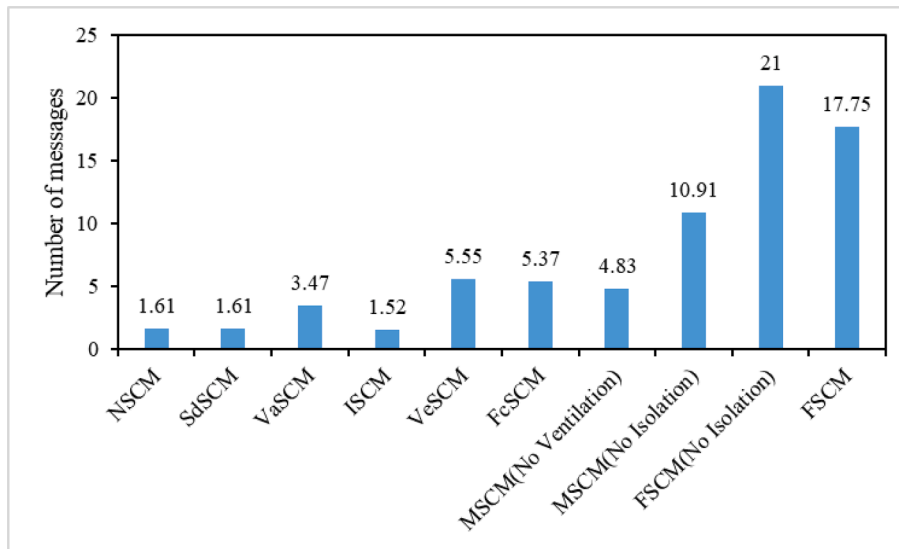

Fig. 18. Number of messages each agent received before transforming into exposed state.

Table 7

Summary (mean and standard deviation) of COVID-19 prevention effectiveness for the 10 scenarios selected.

SCM	Average duration in susceptible state	Message received
NSCM	6.3 (1.48)	160.6 (6.02)
SdSCM	5.76 (0.70)	160.8 (10.21)
VaSCM	9.66 (1.33)	346.8 (14.52)
ISCM	7.98 (2.61)	151.8 (5.81)
VeSCM	11.17 (2.29)	555 (31.28)
FcSCM	10.11 (2.34)	536.8 (84.95)
MSCM(No Ventilation)	21.88 (8.67)	482.6 (79.75)
MSCM(No Isolation)	14.92 (2.56)	1091.2 (171.52)
FSCM(No Isolation)	24.76 (4.80)	2099.8 (260.76)
FSCM	118.41 (2.61)	1774.6 (110.19)

outcomes, which could still be attributed to interactions at lunch breaks.

Fig. 20 further shows the average contact duration of infectious agents during the first 24 h, based on NSCM. The result reveals an exponential distribution of the average contact duration, and it is noticed that the majority of the contact lasts less than 30 mins.

The correlation between SCMs and the peak time and value of COVID-19 transmission is illustrated in Fig. 21. Value 1 and -1 imply the strongest positive and negative correlation between the two variables respectively. Value 0 means there is no correlation between the two variables. A significant correlation was observed between isolation and COVID-19 transmission, as well as between percentage of vaccination and COVID-19 transmission, while the remaining 3 SCMs are less correlated, especially the inability of social distance to prevent the spread of COVID-19. This observed ineffectiveness of social distancing in this case study may be attributed to nature of the work schedule for this particular construction site, whereby all workers are expected to have their lunch breaks between 12:00 pm and 1:00 pm, which in turn leads

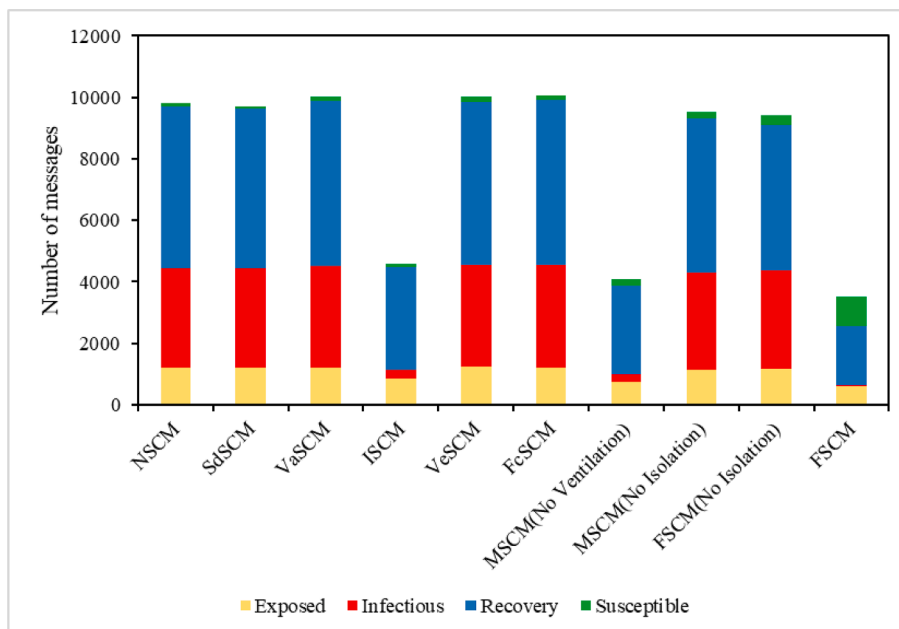

Fig. 19. Number of messages sent by each agent during each state of SEIR.

Table 8
Number of messages (mean and standard deviation) sent by each agent during each state of SEIR.

SCM	Susceptible	Exposed	Infectious	Recovery	Total
NSCM	97.59 (21.01)	1220.97 (78.56)	3229.47 (109.77)	5249.83 (221.48)	9797.86
SdSCM	84.84 (7.93)	1188.79 (16.31)	3264.69 (32.83)	5166.87 (43.03)	9705.19
VaSCM	142.76 (12.33)	1211.41 (28.35)	3284.31 (53.98)	5383.94 (121.29)	10022.4
ISCM	115.28 (31.12)	855.66 (19.94)	295.08 (9.22)	3321.16 (103.91)	4587.18
VeSCM	173.8 (32.41)	1247.91 (28.21)	3293.2 (61.23)	5303.75 (168.33)	10018.7
FcSCM	152.1 (34.05)	1222.21 (32.79)	3319.25 (66.34)	5377.21 (174.61)	10070.8
MSCM(No Ventilation)	236.24 (78.80)	735.41 (45.33)	260.06 (29.99)	2871.91 (138.99)	4103.62
MSCM(No Isolation)	211.13 (26.98)	1148.9 (34.95)	3161.78 (43.62)	5016.81 (104.49)	9538.62
FSCM(No Isolation)	352.92 (62.54)	1169.56 (47.80)	3183.69 (94.41)	4727.51 (167.51)	9433.68
FSCM	953.37 (151.68)	602.41(36.22)	45.92 (4.52)	1899.75 (272.13)	3501.45

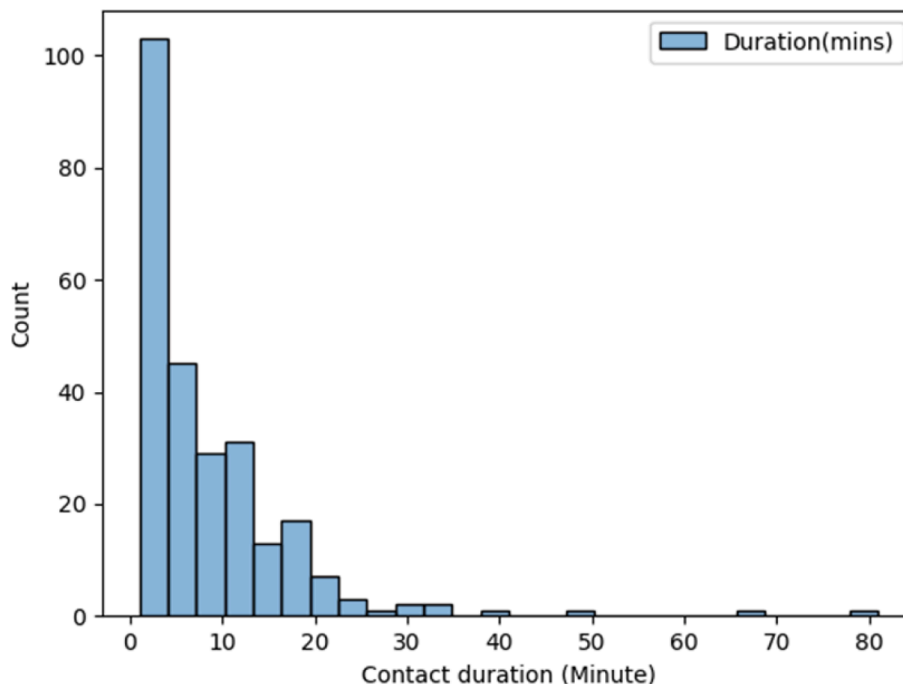

Fig. 20. The average contact duration of NSCM.

to clustering around the canteen. This in turn undermines the effectiveness of social distance rules, irrespective of whether workers are sparsely populated on the site while work.

The hourly COVID-19 infection rate is illustrated in Fig. 22 where the three spikes represent the newly infected population during lunch breaks, while the remaining spikes represent the hourly counts of new infections during work periods. It is observed that the development of infection ends at around 80 h after simulation for all scenarios. A significant portion of the infection took place during the lunch break especially on the first day after the first COVID-19 outbreak. The detailed hourly COVID-19 infection rate during lunch break and working period is listed in Table 9.

The correlation between SCMs and COVID-19 transmission during lunch break and work periods is presented in Fig. 23. The results suggest that vaccination, ventilation and face covering are the three most effective measures in preventing COVID-19 spread during lunch breaks. Isolation rules are less effective mainly because it functioned after first COVID-19 outbreak during this period. In terms of infection during work periods, it is observed that isolation rules are the most effective as it helps stop infectious workers attending the work the next day.

The core functionalities and applicability of the model and platform were further enhanced based on the feedback received from experts that represented large construction firms within the UK. Full details of the responses received are available within Appendix 4, where it could be

observed that their comments are mostly positive, which could be an indication of the potentials of the platform to be integrated into existing safety management systems.

5. Conclusion

A proof-of-concept like model that integrated ABM and SEIR modelling approaches in an interactive and user-friendly manner was established to simulate the dynamics of COVID-19 transmission and the epidemiological effects of various protective control measures, including social distancing, face covering, vaccinations rate, ventilation, and isolation. The model also considered population heterogeneity (e.g., age, vaccination status and household size), duration of contacts and site layout.

The work detailed how the model was built on an interactive and user-friendly platform using AnyLogic. In addition, it also showcased how to use the model and platform for estimating the transmission risk and identifying high-risk work areas on a construction site under COVID-19 outbreak. In particular, the work enables users to select the level of compliance for different protective control measures so as to create different scenarios and visualise how different scenarios can affect the COVID transmission dynamic as well as the identification of high-risk areas. As a result, users can identify the scenario (i.e., a combination of compliance on different protective control measures) that is

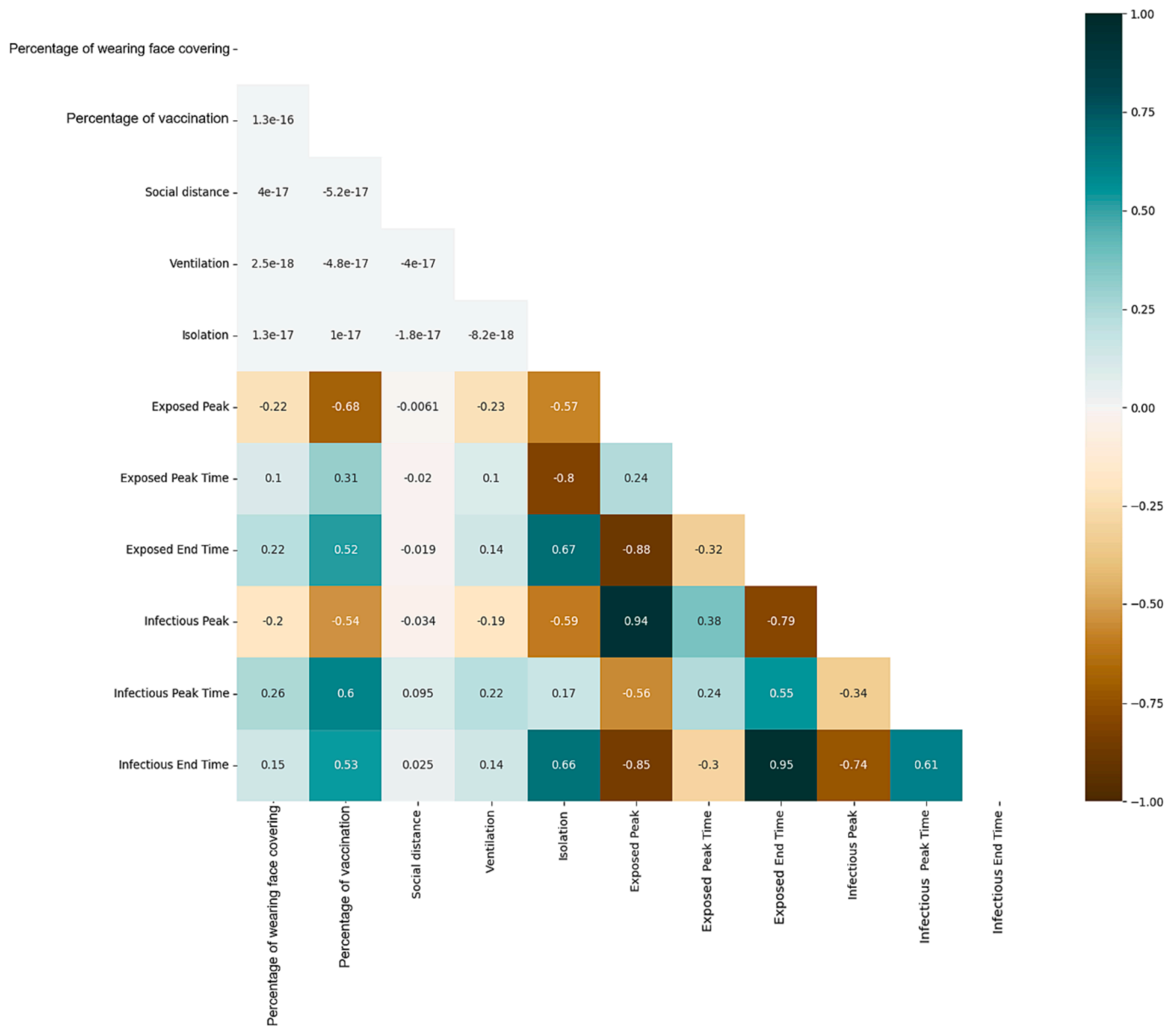

Fig. 21. The correlation between SCMs and the peak time and value of COVID-19 transmission.

optimal with the consideration of operational costs and controlling the spread of the diseases.

The results of COVID-19 development on a construction site based on various safety control measures scenarios revealed a strong positive correlation between preventing COVID-19 transmission risk and vaccination status as well as isolation. The use of face covering and maintaining good ventilation can to a certain extent alleviate the spread of COVID-19. As a labour-intensive space where agents have to physically collaborate within close proximities, maintaining social distance is difficult to comply with. It is also revealed that COVID-19 transmission during lunch breaks contributed to a significant portion of the total infections, despite the implementation of several protective control measures. Especially, compliance with social distance rules was impeded by the clustering of workers in the canteen.

In order to ascertain the usability of the model in real life, an engagement session was held with professionals from the industry. While most of the feedback received during the sessions were mostly positive, such outputs were still used to enhance certain core functionalities of the platform to increase its potential to be integrated into

existing safety management systems.

Since the first confirmed case of COVID-19 in December 2019, COVID-19 has been evolving from a wild variant then to Alpha, Beta, Delta, Omicron, etc. The characteristics in terms of transmission capability and severity vary dramatically. The Omicron variant was emerging when this study began, therefore, the parameters of COVID-19 applied in this study focus on the Delta variant. Also, with a better understanding of COVID-19, the value of parameters of the Delta variant of COVID-19 may have a certain possibility that is different from what is quoted in this study. The main vectors of COVID-19 virus revealed by existing research are droplet and airborne. It should be emphasised in this study that the ‘message’ or the virus the infectious agent sends to his/her surrounding is droplets as there is a lack of comprehensive understanding about the impact of airborne on COVID-19 transmission, thereby constituting one of the potential future research directions of COVID-19 transmission modelling.

SEIR model was employed in this study for describing the pathogenesis of COVID-19 where COVID-19 was divided into ‘Susceptible’, ‘Exposed’, ‘Infectious’ and ‘Recovery’ states and the values of

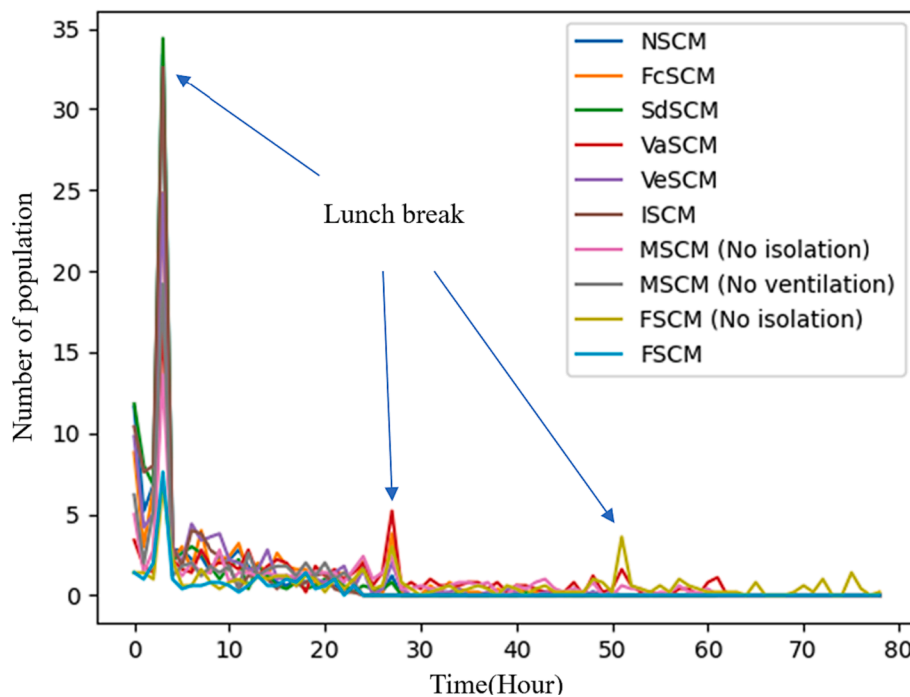

Fig. 22. Hourly COVID-19 infection rate.

Table 9
COVID-19 development during lunch and working periods (mean and standard deviation) based on different SCMs scenarios.

Scenario	[Fc, Sd, Va, Ve, I]	Infection during lunch break	Infection during working period
NSCM	[0, 0, 0, 0, 0]	34.6 (4.04)	65.4 (4.04)
FcSCM	[1, 0, 0, 0, 0]	28.6 (7.16)	71.4 (7.16)
SdSCM	[0, 1, 0, 0, 0]	35.2 (3.03)	64.8 (3.03)
VaSCM	[0, 0, 1, 0, 0]	24.8 (2.68)	75.2 (2.68)
VeSCM	[0, 0, 0, 1, 0]	26.8 (2.77)	73.2 (2.77)
ISCM	[0, 0, 0, 0, 1]	32.6 (6.42)	66.8 (5.81)
MSCM (No isolation)	[0.5, 0.5, 0.5, 1, 0]	17.0 (6.28)	83.0 (6.28)
MSCM (No ventilation)	[0.5, 0.5, 0.5, 0, 1]	19.2 (3.11)	61.0 (8.92)
FSCM (No isolation)	[1, 1, 1, 1, 0]	6.8 (3.03)	82.6 (3.36)
FSCM	[1, 1, 1, 1, 1]	7.6 (1.50)	36.6 (3.05)

parameters regarding COVID-19 (for instance, transmission probability per contact and incubation duration) were acquired from a wide range of resources that were mostly based on experimental or publicly available data, which are inevitably less representative for all countries or areas worldwide. It should be emphasised that the established COVID-19 transmission model in this study does not aim at providing an exact prediction about the development of COVID-19 on a construction site, but rather, the foundation to evaluate the feasibility of the proposed integrated ABM and SEIR framework in simulating COVID-19 transmission. The limitation of the integrated model exists in the following aspects. First, it should be noted that the COVID-19 simulation in this model is based on an extreme scenario for demonstration purpose. For instance, the basic transmission probability of each contact is 50% which was derived from the COVID-19 human challenge experiment (Killingley et al., 2022) (i.e., volunteers were directly exposed to the COVID-19 virus and the result indicated that half of the volunteers became infected). However, a 50% chance of infection from a single exposure to the COVID-19 is considered unlikely. Also, the simulation assumed that 10 messages were randomly sent to agents at the beginning

of the simulation to create an outbreak of COVID-19, so as to evaluate the effectiveness of different safety control measures. This assumption may not be a true representation of all cases in reality. In addition, the purpose of safety control measures is to investigate the relative potential of each measure in mitigating COVID-19 transmission, but not the feasibility of implementing those measures in practice. For instance, it may not be possible to isolate a new infectious agent immediately (e.g., FSCM in the report) unless regular daily testing for COVID-19 is conducted on site. It is important to highlight that the construction site examined in this study was regarded as an enclosed system, wherein the agents/workers were not exposed to any potentially hazardous environments beyond the confines of the system (e.g., transportation and dormitories in certain large and/or remote sites). However, transportation and dormitories are significantly associated with poor ventilation, lack of social distancing and poor hygiene, which may to a great extent affect the status (i.e., susceptible/exposed/infected/recovery) of an agent/worker when entering the construction site. Additionally, further analyses have revealed that COVID-19 is more than just ‘SEIR’ states. For instance, ‘Infectious’ is further divided into pre-symptom, asymptomatic and symptomatic. Besides, some parameters are far more complex (e.g., a function of time) instead of a fixed value that is not captured in this study.

CRedit authorship contribution statement

Qingyao Qiao: Methodology, Software, Validation, Formal analysis, Investigation, Resources, Data curation, Writing – original draft, Visualisation. **Clara Cheung:** Conceptualisation, Methodology, Software, Validation, Formal analysis, Investigation, Resources, Data curation, Writing – review & editing, Supervision, Project administration, Funding acquisition. **Akilu Yunusa-Kaltungo:** Conceptualisation, Methodology, Software, Validation, Formal analysis, Investigation, Resources, Data curation, Writing – review & editing, Supervision, Project administration, Funding acquisition. **Patrick Manu:** Conceptualisation, Methodology, Software, Validation, Formal analysis, Investigation, Resources, Data curation, Writing – review & editing, Supervision, Project administration, Funding acquisition. **Ruifeng Cao:** Methodology, Software, Formal analysis, Investigation, Data curation, Writing – original

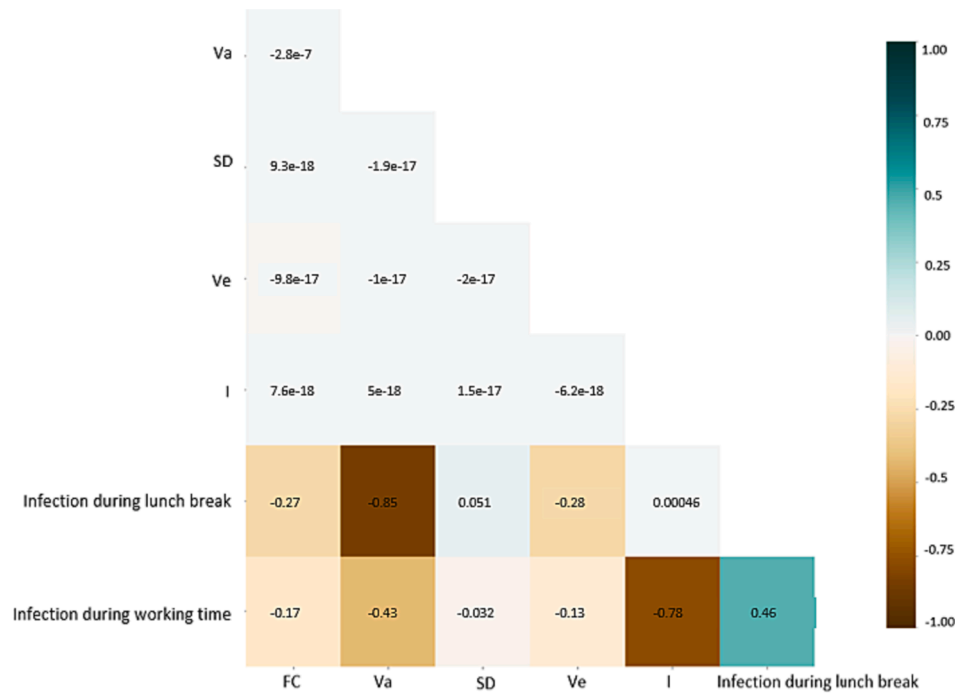

Fig. 23. The correlation between SCMs and COVID-19 transmission during lunch break and working time.

draft, Visualisation. Ziyue Yuan: Methodology, Writing – review & editing.

Acknowledgement

This work was funded by the PROTECT COVID-19 National Core Study on transmission and environment which is managed by The Health and Safety Executive (HSE) on behalf of HM Government. Its contents, including any opinions and/or conclusions expressed, are those of the authors alone and do not necessarily reflect Government or HSE Policy.

Declaration of Competing Interest

The authors declare that they have no known competing financial interests or personal relationships that could have appeared to influence the work reported in this paper.

Appendix

Appendix 1 108 Scenarios of the five SCMs.

Scenario	Fc [0, 0.5, 1]	Va [0, 0.5, 1]	Sd [0, 0.5, 1]	Ve [0, 1]	I [0, 1]
1	0	0	0	0	0
2	0	0	0	0	1
3	0	0	0	1	0
4	0	0	0	1	1
5	0	0	0.5	0	0
6	0	0	0.5	0	1
7	0	0	0.5	1	0
8	0	0	0.5	1	1
9	0	0	1	0	0
10	0	0	1	0	1
11	0	0	1	1	0
12	0	0	1	1	1
13	0	0.5	0	0	0
14	0	0.5	0	0	1
15	0	0.5	0	1	0
16	0	0.5	0	1	1
17	0	0.5	0.5	0	0
18	0	0.5	0.5	0	1
19	0	0.5	0.5	1	0
20	0	0.5	0.5	1	1
21	0	0.5	1	0	0
22	0	0.5	1	0	1
23	0	0.5	1	1	0
24	0	0.5	1	1	1

(continued on next page)

(continued)

Scenario	Fc [0, 0.5, 1]	Va [0, 0.5, 1]	Sd [0, 0.5, 1]	Ve [0, 1]	I [0, 1]
25	0	c	0	0	0
26	0	1	0	0	1
27	0	1	0	1	0
28	0	1	0	1	1
29	0	1	0.5	0	0
30	0	1	0.5	0	1
31	0	1	0.5	1	0
32	0	1	0.5	1	1
33	0	1	1	0	0
34	0	1	1	0	1
35	0	1	1	1	0
36	0	1	1	1	1
37	0.5	0	0	0	0
38	0.5	0	0	0	1
39	0.5	0	0	1	0
40	0.5	0	0	1	1
41	0.5	0	0.5	0	0
42	0.5	0	0.5	0	1
43	0.5	0	0.5	1	0
44	0.5	0	0.5	1	1
45	0.5	0	1	0	0
46	0.5	0	1	0	1
47	0.5	0	1	1	0
48	0.5	0	1	1	1
49	0.5	0.5	0	0	0
50	0.5	0.5	0	0	1
51	0.5	0.5	0	1	0
52	0.5	0.5	0	1	1
53	0.5	0.5	0.5	0	0
54	0.5	0.5	0.5	0	1
55	0.5	0.5	0.5	1	0
56	0.5	0.5	0.5	1	1
57	0.5	0.5	1	0	0
58	0.5	0.5	1	0	1
59	0.5	0.5	1	1	0
60	0.5	0.5	1	1	1
61	0.5	1	0	0	0
62	0.5	1	0	0	1
63	0.5	1	0	1	0
64	0.5	1	0	1	1
65	0.5	1	0.5	0	0
66	0.5	1	0.5	0	1
67	0.5	1	0.5	1	0
68	0.5	1	0.5	1	1
69	0.5	1	1	0	0
70	0.5	1	1	0	1
71	0.5	1	1	1	0
72	0.5	1	1	1	1
73	1	0	0	0	0
74	1	0	0	0	1
75	1	0	0	1	0
76	1	0	0	1	1
77	1	0	0.5	0	0
78	1	0	0.5	0	1
79	1	0	0.5	1	0
80	1	0	0.5	1	1
81	1	0	1	0	0
82	1	0	1	0	1
83	1	0	1	1	0
84	1	0	1	1	1
85	1	0.5	0	0	0
86	1	0.5	0	0	1
87	1	0.5	0	1	0
88	1	0.5	0	1	1
89	1	0.5	0.5	0	0
90	1	0.5	0.5	0	1
91	1	0.5	0.5	1	0
92	1	0.5	0.5	1	1
93	1	0.5	1	0	0
94	1	0.5	1	0	1
95	1	0.5	1	1	0
96	1	0.5	1	1	1
97	1	1	0	0	0
98	1	1	0	0	1
99	1	1	0	1	0
100	1	1	0	1	1

(continued on next page)

(continued)

Scenario	Fc [0, 0.5, 1]	Va [0, 0.5, 1]	Sd [0, 0.5, 1]	Ve [0, 1]	I [0, 1]
101	1	1	0.5	0	0
102	1	1	0.5	0	1
103	1	1	0.5	1	0
104	1	1	0.5	1	1
105	1	1	1	0	0
106	1	1	1	0	1
107	1	1	1	1	0
108	1	1	1	1	1

Appendix 2. The user interface of the proposed ABM-SEIR model



Appendix 3. Results summary of 108 scenarios of the five SCMs

No	[Fc, Sd, Va, Ve, I]	Infection during lunch break	Infection during working time	Peak value (Exposed)	Peak time (Exposed)	End time (Exposed)	Peak value (Infectious)	Peak time (Infectious)	End time (Infectious)
1	[0, 0, 0, 0, 0]	33.4	1	91.2	49	158	100	158	414
2	[0, 0, 0, 0, 1]	32.6	0.38	88.4	24	241	99.2	193	482

(continued on next page)

(continued)

No	[Fc, Sd, Va, Ve, I]	Infection during lunch break	Infection during working time	Peak value (Exposed)	Peak time (Exposed)	End time (Exposed)	Peak value (Infectious)	Peak time (Infectious)	End time (Infectious)
3	[0, 0, 0, 1, 0]	24.8	1.09	91.2	51	167	100	167	422
4	[0, 0, 0, 1, 1]	25.2	0.43	83.4	24	238	99.2	203	487
5	[0, 0, 0.5, 0, 0]	29	0.71	92	45	183	100	183	421
6	[0, 0, 0.5, 0, 1]	27.2	0.5	83.8	24	223	99	208	486
7	[0, 0, 0.5, 1, 0]	26.6	0.77	91.4	49	165	100	165	427
8	[0, 0, 0.5, 1, 1]	16.8	0.32	75	24	300	96	215	537
9	[0, 0, 1, 0, 0]	34.4	0.91	90	42	160	100	160	418
10	[0, 0, 1, 0, 1]	36	0.37	87	24	199	99.6	199	439
11	[0, 0, 1, 1, 0]	31.6	0.62	89.6	52	177	100	177	426
12	[0, 0, 1, 1, 1]	28.8	0.32	84.4	24	270	99	218	534
13	[0, 0.5, 0, 0, 0]	20.6	0.63	86.6	64	222	100	222	468
14	[0, 0.5, 0, 0, 1]	27.4	0.26	71	24	310	92.6	220	556
15	[0, 0.5, 0, 1, 0]	16.8	0.57	80.6	77	232	99.4	215	502
16	[0, 0.5, 0, 1, 1]	11.8	0.2	53.8	24	409	80.2	221	668
17	[0, 0.5, 0.5, 0, 0]	16.4	0.6	87.4	59	216	99.6	209	459
18	[0, 0.5, 0.5, 0, 1]	19.6	0.25	69.4	25	324	90.2	220	569
19	[0, 0.5, 0.5, 1, 0]	16.8	0.43	77.4	67	285	94.8	220	554
20	[0, 0.5, 0.5, 1, 1]	12.6	0.16	53.8	70	448	76.4	219	699
21	[0, 0.5, 1, 0, 0]	19.2	0.64	86.8	61	231	98.2	192	498
22	[0, 0.5, 1, 0, 1]	21.4	0.18	66.4	23	449	87.8	226	694
23	[0, 0.5, 1, 1, 0]	19.6	0.53	79.6	65	265	96.2	203	525
24	[0, 0.5, 1, 1, 1]	13.2	0.15	49.4	25	395	74.4	229	719
25	[0, 1, 0, 0, 0]	17.4	0.67	83.8	66	216	98.8	216	472
26	[0, 1, 0, 0, 1]	13	0.2	56.6	25	456	82.8	224	687
27	[0, 1, 0, 1, 0]	8.6	0.2	74	82	319	97.4	221	537
28	[0, 1, 0, 1, 1]	9	0.18	42	25	406	64	237	664
29	[0, 1, 0.5, 0, 0]	13.4	0.38	80.8	63	298	99.6	222	524
30	[0, 1, 0.5, 0, 1]	12.2	0.26	52.6	24	358	83.8	225	609
31	[0, 1, 0.5, 1, 0]	8.8	0.55	69.4	89	278	96.8	231	543
32	[0, 1, 0.5, 1, 1]	5.8	0.15	35.4	63	456	60.6	225	671
33	[0, 1, 1, 0, 0]	16	0.65	83.4	69	212	98.8	196	473
34	[0, 1, 1, 0, 1]	13.6	0.2	58.2	25	385	82.4	227	654
35	[0, 1, 1, 1, 0]	9.2	0.66	72.4	79	247	96.2	227	504
36	[0, 1, 1, 1, 1]	8.2	0.14	38.2	24	395	55.2	227	673
37	[0.5, 0, 0, 0, 0]	31.6	0.57	91.2	52	196	100	196	438
38	[0.5, 0, 0, 0, 1]	30.6	0.4	81.2	24	224	98.8	211	502
39	[0.5, 0, 0, 1, 0]	24.2	0.77	90	52	193	100	193	446

(continued on next page)

(continued)

No	[Fc, Sd, Va, Ve, I]	Infection during lunch break	Infection during working time	Peak value (Exposed)	Peak time (Exposed)	End time (Exposed)	Peak value (Infectious)	Peak time (Infectious)	End time (Infectious)
40	[0.5, 0, 0, 1, 1]	26.6	0.28	80	25	304	98	210	531
41	[0.5, 0, 0.5, 0, 0]	26.4	0.72	91	52	202	99.8	178	445
42	[0.5, 0, 0.5, 0, 1]	26.4	0.4	82.2	24	244	98.8	200	494
43	[0.5, 0, 0.5, 1, 0]	17.4	0.74	90	52	203	99.8	203	473
44	[0.5, 0, 0.5, 1, 1]	20.6	0.28	75.6	24	334	96.6	214	559
45	[0.5, 0, 1, 0, 0]	29.8	0.53	89.6	46	199	100	199	453
46	[0.5, 0, 1, 0, 1]	29.2	0.3	82.6	39	234	98.6	220	482
47	[0.5, 0, 1, 1, 0]	23.2	0.71	89	52	198	100	198	446
48	[0.5, 0, 1, 1, 1]	25.6	0.15	79.8	24	337	97.4	218	675
49	[0.5, 0.5, 0, 0, 0]	17.4	0.47	81	68	250	99	220	509
50	[0.5, 0.5, 0, 0, 1]	20.6	0.18	62.8	24	407	87	219	647
51	[0.5, 0.5, 0, 1, 0]	13.4	0.37	73.4	67	274	97	222	531
52	[0.5, 0.5, 0, 1, 1]	14.6	0.15	51.4	24	445	74.8	221	657
53	[0.5, 0.5, 0.5, 0, 0]	13	0.56	80.4	67	243	97.8	219	491
54	[0.5, 0.5, 0.5, 0, 1]	19.2	0.14	63	57	494	84.6	220	696
55	[0.5, 0.5, 0.5, 1, 0]	13.6	0.41	74.2	76	269	96	211	538
56	[0.5, 0.5, 0.5, 1, 1]	10.8	0.11	50.8	24	489	69.6	212	719
57	[0.5, 0.5, 1, 0, 0]	15.2	0.47	79.2	65	265	96	227	498
58	[0.5, 0.5, 1, 0, 1]	21.4	0.18	61	24	420	81.8	229	629
59	[0.5, 0.5, 1, 1, 0]	13	0.32	73.4	78	350	94.4	250	618
60	[0.5, 0.5, 1, 1, 1]	13.4	0.22	48.8	24	369	70.4	267	621
61	[0.5, 1, 0, 0, 0]	9.6	0.52	76.6	77	263	98	218	521
62	[0.5, 1, 0, 0, 1]	13	0.13	48.6	24	481	70.2	220	712
63	[0.5, 1, 0, 1, 0]	7.8	0.38	62.2	79	326	92.8	240	563
64	[0.5, 1, 0, 1, 1]	7.6	0.05	32.6	52	409	48.6	230	658
65	[0.5, 1, 0.5, 0, 0]	9.6	0.54	73.4	76	261	97.6	224	516
66	[0.5, 1, 0.5, 0, 1]	10.8	0.13	42.4	24	569	68.4	231	710
67	[0.5, 1, 0.5, 1, 0]	8.4	0.41	60.8	87	318	92.4	235	559
68	[0.5, 1, 0.5, 1, 1]	5.8	0.09	30	25	501	46	224	710
69	[0.5, 1, 1, 0, 0]	15.2	0.5	75.6	76	259	95.4	226	507
70	[0.5, 1, 1, 0, 1]	13.2	0.18	49.8	24	438	73	234	682
71	[0.5, 1, 1, 1, 0]	7.8	0.4	67.6	87	318	92.2	226	543
72	[0.5, 1, 1, 1, 1]	10.2	0.12	36.4	25	516	55.8	225	660
73	[1, 0, 0, 0, 0]	24.8	0.73	91	45	189	100	189	454
74	[1, 0, 0, 0, 1]	24	0.31	82	24	254	98.2	196	504
75	[1, 0, 0, 1, 0]	23.6	0.7	90.4	55	187	100	187	448
76	[1, 0, 0, 1, 1]	19	0.16	72	24	467	94.4	216	615

(continued on next page)

(continued)

No	[Fc, Sd, Va, Ve, I]	Infection during lunch break	Infection during working time	Peak value (Exposed)	Peak time (Exposed)	End time (Exposed)	Peak value (Infectious)	Peak time (Infectious)	End time (Infectious)
77	[1, 0, 0.5, 0, 0]	19.2	0.88	91	52	186	100	186	444
78	[1, 0, 0.5, 0, 1]	21.4	0.27	76.2	24	361	95.4	211	595
79	[1, 0, 0.5, 1, 0]	18	0.79	90	52	213	99.8	200	438
80	[1, 0, 0.5, 1, 1]	17.4	0.29	68.6	25	339	93.4	231	607
81	[1, 0, 1, 0, 0]	27	0.72	89.6	52	172	100	172	435
82	[1, 0, 1, 0, 1]	27.6	0.31	82.4	24	296	97.8	217	553
83	[1, 0, 1, 1, 0]	25.4	0.65	88.6	55	190	100	190	440
84	[1, 0, 1, 1, 1]	25.6	0.29	77.4	25	309	96.6	218	506
85	[1, 0.5, 0, 0, 0]	11.6	0.51	77.4	71	274	98.4	222	545
86	[1, 0.5, 0, 0, 1]	15.2	0.14	56	56	521	77	220	669
87	[1, 0.5, 0, 1, 0]	12.6	0.45	73.2	76	271	94.4	222	521
88	[1, 0.5, 0, 1, 1]	12.4	0.17	47.6	25	402	70.2	222	636
89	[1, 0.5, 0.5, 0, 0]	11.8	0.53	75.6	73	260	96.6	210	502
90	[1, 0.5, 0.5, 0, 1]	12.6	0.15	52.4	24	459	72.8	219	709
91	[1, 0.5, 0.5, 1, 0]	8.8	0.41	69.6	71	281	94.8	220	554
92	[1, 0.5, 0.5, 1, 1]	9.8	0.14	45.2	64	451	65	219	614
93	[1, 0.5, 1, 0, 0]	15.4	0.45	74.2	76	275	95	227	539
94	[1, 0.5, 1, 0, 1]	16	0.16	51.4	61	451	70.4	229	681
95	[1, 0.5, 1, 1, 0]	12.8	0.44	70.8	77	305	93.4	287	585
96	[1, 0.5, 1, 1, 1]	12.2	0.13	44.6	25	531	65.4	229	678
97	[1, 1, 0, 0, 0]	10.2	0.51	69	78	285	95.8	228	537
98	[1, 1, 0, 0, 1]	7.2	0.1	38.8	24	512	57.8	235	694
99	[1, 1, 0, 1, 0]	3.6	0.33	57.2	109	375	92.2	287	626
100	[1, 1, 0, 1, 1]	5.2	0.13	28.2	24	382	44	223	610
101	[1, 1, 0.5, 0, 0]	4.4	0.43	64.6	100	307	93.2	225	558
102	[1, 1, 0.5, 0, 1]	7.4	0.11	31.2	25	494	52.4	219	689
103	[1, 1, 0.5, 1, 0]	6.2	0.3	58.2	104	385	91.4	294	611
104	[1, 1, 0.5, 1, 1]	4	0.06	21.8	25	492	37	219	566
105	[1, 1, 1, 0, 0]	7.6	0.47	69.6	79	268	93.8	226	512
106	[1, 1, 1, 0, 1]	10.8	0.12	40.6	24	361	57.4	226	611
107	[1, 1, 1, 1, 0]	6.8	0.38	56.2	100	339	90.8	271	609
108	[1, 1, 1, 1, 1]	7.6	0.09	25.8	24	443	41	227	662

Appendix 4 Feedback template on the four criteria set to evaluate the model.

Assessment Criteria	Comments	Improvements and suggestions
C1 Usability of the platform	<p><i>"It's very plug and play, very interactive."</i></p> <p><i>"I think on the basis of what you've presented so far, taking away those logic pieces and quietening down the screen to have those functions of adding in or taking out control measures, would be pretty functionally usable. As long as it was able to help us to formulate a quantitative risk assessment on things like, what would the R rate be on our project"</i></p>	<p><i>"We would probably need to see what it would look like in its final user usable state."</i></p>

(continued on next page)

(continued)

Assessment Criteria	Comments	Improvements and suggestions
	potentially.” “I see this as being potentially something which this model might be able to give us in terms of a quantitative reproduction number based on the project behaviour. As you talked about, everything through from behaviours through two particular risk areas of and hot spots and transmission within that model, might enable us to create a more quantitative risk assessment where we can be more certain in terms of the required controls that we need to identify to manage that situation.”	
C2 Structure and layout	“In terms of the structure and layout, I don’t have any major issues with that. I think you know that’s something that can be evolved over time, as you make it less busy, as you make it more user friendly.” “I think it looked great. The usability and structure of it. It seems you can put anything in. I guess it would be just more on our end of how we use it and how good the data is that we put in.”	“That’s something I think we’ll just need to keep working with you on and put that in front of some of our NHS professionals to see how they would work with that particularly.”
C3 Ease of integration with other platforms	“As with all of these things, we want to pull the information into a central source such as power BI because we use power apps for an awful lot of the data that we put together. So, our construction data is visible on power BI and that will be something very simply.” “All into one system, the power BI, we definitely follow that sort of trend here and it would be more for me because the data going into it. It looks like you are capable of putting anything in the model obviously how we would monitor it on site and then pull that data back in.”	“We would need to be able to have an API that we can plug into power BI from the system to tell us vital information about our numbers by project. So if you have this running on each individual project, our health and safety managers, occupational health managers would be utilising this model on a project by project basis and we would want to be able to see a project specific data alongside business wide overview as well, and that would be something where an API would be vitally important in enabling us to reproduce the information onto dashboards and other visual representation of that, so that our leadership team could be pulling on the rope of that information and monitoring that effectively.”
C4 Representativeness and relevance of captured information	“I would just probably say, any system is only as good as what you put into it, and it’s for you then falls to us to, as you say, get and put that work scheduling in, get those accurate representations of what the entire project looks like, what the floor plates would look like, what the welfare and office space would look like, to enable us to have that relevance to the project. So, the detail would be absolutely vital here in having something which actually provides us with that quantitative rather than the qualitative nature of the information.” “The control measures might vary in different areas. Rather than just saying social distance in its two meters everywhere where we’ve got rid of that in some places, we’ve left open some places. We’ve got sort of the canteens might still be 2 m, but have you walking down certain corridors, it might go back to whatever. Obviously if it’s for modelling future ways, if we do go back into a pandemic, then we will be set at 2 m everywhere. But in terms of modelling, how it is now and how it is on different sites.”	“I think the control measures might vary in different rooms or areas which could be a good thing to see if you could change the variables.”

References

- Afkhamiaghda, M., Elwakil, E., 2020. Preliminary modeling of Coronavirus (COVID-19) spread in construction industry. *Journal of Emergency Management* 18 (7), 9–17. <https://doi.org/10.5055/JEM.2020.0481>.
- UK Health Security Agency (2022) Guidance for contacts of people with confirmed coronavirus (COVID-19) infection who do not live with the person. Available online at: <https://www.gov.uk/government/publications/guidance-for-contacts-of-people-with-possible-or-confirmed-coronavirus-covid-19-infection-who-do-not-live-with-the-person/guidance-for-contacts-of-people-with-possible-or-confirmed-coronavirus-covid-19-infection-who-do-not-live-with-the-person> (Accessed 9 March 2023).
- Allan-Blitz, L.-T. et al. (2020) ‘High frequency and prevalence of community-based asymptomatic SARS-CoV-2 infection’, *medRxiv*, p. 2020.12.09.20246249.
- Alsharef, A., et al., January 2020. (2021) ‘Early Impacts of the COVID-19 Pandemic on the United States Construction Industry’. *International Journal of Environmental Research and Public Health* 18, 1559.
- Araya, F., 2021a. Modeling the spread of COVID-19 on construction workers: An agent-based approach. *Safety Science* 133. <https://doi.org/10.1016/j.ssci.2020.105022>.
- Araya, F., 2021b. Modeling working shifts in construction projects using an agent-based approach to minimize the spread of COVID-19. *Journal of Building Engineering* 41. <https://doi.org/10.1016/j.jobe.2021.102413>.
- Araya, F., 2022. Modeling the influence of multiskilled construction workers in the context of the covid-19 pandemic using an agent-based approach. *Revista de la Construcción* 21 (1), 105–117. <https://doi.org/10.7764/RDLC.21.1.105>.
- Bakker, P.E. and Halford, G.S. (1988) ‘A basic computational theory of structure-mapping in analogy and transitive inference’, (May 1996).
- Bossert, A. et al. (2021) ‘Limited containment options of COVID-19 outbreak revealed by regional agent-based simulations for South Africa’, *F1000Research*, 10, p. 98. Available at: Doi: 10.12688/f1000research.28250.1.
- Burridge, H.C. et al. (2021) *The ventilation of buildings and other mitigating measures for COVID-19: A focus on wintertime*. *Proceedings of the Royal Society A: Mathematical, Physical and Engineering Sciences*. Doi: 10.1098/rspa.2020.0855.
- Chen, J., et al., 2021. Epidemiological and economic impact of COVID-19 in the US. *Scientific Reports* 11 (1), 1–12. <https://doi.org/10.1038/s41598-021-99712-z>.
- Chen, C.-Y., et al., 2023. Recommendations for ventilation of remodeled negative-pressure isolation wards for COVID-19 patients: A comparison of international guidelines. *Journal of the Formosan Medical Association* 122 (2), 91–97. <https://doi.org/10.1016/j.jfma.2022.11.013>.
- Chu, D.K., et al., 2020. Physical distancing, face masks, and eye protection to prevent person-to-person transmission of SARS-CoV-2 and COVID-19: a systematic review and meta-analysis. *The Lancet* 395 (10242), 1973–1987. [https://doi.org/10.1016/S0140-6736\(20\)31142-9](https://doi.org/10.1016/S0140-6736(20)31142-9).
- Dai, H., Zhao, B., 2020. Association of the infection probability of COVID-19 with ventilation rates in confined spaces. *Building simulation* 13 (6), 1321–1327. <https://doi.org/10.1007/s12273-020-0703-5>.
- Ferguson, H.R.P. and Bailey, D.H. (1992) ‘A polynomial time, numerically stable integer relation algorithm’, (January), pp. 1–14.
- Gerami Seresht, N., 2022. Enhancing resilience in construction against infectious diseases using stochastic multi-agent approach. *Automation in Construction* 140. <https://doi.org/10.1016/j.autcon.2022.104315>.
- Helbing, D., Molnár, P., 1995. Social force model for pedestrian dynamics. *Physical Review E* 51 (5), 4282–4286. <https://doi.org/10.1103/PhysRevE.51.4282>.
- Housing design quality and standards supplementary planning guidance* (2019).
- Huang, C., et al., 2020. Clinical features of patients infected with 2019 novel coronavirus in Wuhan, China. *The Lancet* 395 (10223), 497–506. [https://doi.org/10.1016/S0140-6736\(20\)30183-5](https://doi.org/10.1016/S0140-6736(20)30183-5).
- Issa, U.H., et al., 2021. Developing a Risk Model for Assessment and Control of the Spread of COVID-19. Available at: <https://doi.org/10.3390/risks>.
- Jallow, H., Renukappa, S., Suresh, S., 2021. The impact of COVID-19 outbreak on United Kingdom infrastructure sector. *Smart and Sustainable Built Environment* 10 (4), 581–593. <https://doi.org/10.1108/SASBE-05-2020-0068>.
- Jefferson, T., et al., 2008. Physical interventions to interrupt or reduce the spread of respiratory viruses: Systematic review. *Bmj* 336 (7635), 77–80. <https://doi.org/10.1136/bmj.39393.510347.BE>.
- Kang, M. et al. (2021) ‘Transmission dynamics and epidemiological characteristics of Delta variant infections in China’, *medRxiv*, p. 2021.08.12.21261991.
- Killingley, B., et al., 2022. Safety, tolerability and viral kinetics during SARS-CoV-2 human challenge in young adults. *Nature Medicine* 28 (5), 1031–1041. <https://doi.org/10.1038/s41591-022-01780-9>.
- Killingley, B. et al. (2022) ‘COVID-19 human challenge study reveals detailed insights into infection’ *Imperial News*, Imperial College London.

- Kim, P., et al., 2022. 'Duration of Severe Acute Respiratory Syndrome Coronavirus 2 Natural Immunity and Protection Against the Delta Variant: A Retrospective Cohort Study', *Clinical infectious diseases: an official publication of the Infectious Diseases Society of America* 75 (1), e185–e190. <https://doi.org/10.1093/cid/ciab999>.
- Lauring, A.S. et al. (2022) 'Clinical Severity and mRNA Vaccine Effectiveness for Omicron, Delta, and Alpha SARS-CoV-2 Variants in the United States: A Prospective Observational Study.', *medRxiv : the preprint server for health sciences* [Preprint]. Doi: 10.1101/2022.02.06.22270558.
- Lopez Bernal, J., et al., 2021. Effectiveness of Covid-19 Vaccines against the B.1.617.2 (Delta) Variant. *New England Journal of Medicine* 385 (7), 585–594. <https://doi.org/10.1056/nejmoa2108891>.
- Luo, X., et al., 2021. Suitability of human settlements in mountainous areas from the perspective of ventilation: A case study of the main urban area of Chongqing. *Journal of Cleaner Production* 310. <https://doi.org/10.1016/j.jclepro.2021.127467>.
- Luo, Y., et al., 2023. Carbon footprint assessment of face masks in the context of the COVID-19 pandemic: Based on different protective performance and applicable scenarios. *Journal of Cleaner Production* 387. <https://doi.org/10.1016/j.jclepro.2023.135854>.
- Madewell, Z.J. et al. (2020) 'REACT-1 round 15 interim report: High and rising prevalence of SARS-CoV-2 infection in England from end of September 2021 followed by a fall in late October 2021', *medRxiv*, (165), pp. 1–13.
- Mathur, R., et al., 2021. Ethnic differences in SARS-CoV-2 infection and COVID-19-related hospitalisation, intensive care unit admission, and death in 17 million adults in England: an observational cohort study using the OpenSAFELY platform. *The Lancet* 397 (10286), 1711–1724. [https://doi.org/10.1016/S0140-6736\(21\)00634-6](https://doi.org/10.1016/S0140-6736(21)00634-6).
- Mikulčić, H., et al., 2021. Sustainable development in period of COVID-19 pandemic. *Journal of Cleaner Production* 328, 129577. <https://doi.org/10.1016/j.jclepro.2021.129577>.
- Mourad, A., Mroue, F., Taha, Z., 2022. Stochastic mathematical models for the spread of COVID-19: A novel epidemiological approach. *Mathematical Medicine and Biology* 39 (1), 49–76. <https://doi.org/10.1093/imammb/dqab019>. Available at: <https://doi.org/10.1186/s13104-020-05192-1>.
- Mwalli, S., et al., 2020. 'SEIR model for COVID-19 dynamics incorporating the environment and social distancing', *BMC Research Notes*, 13(1). Available at: <https://doi.org/10.1186/s13104-020-05192-1>.
- Nanduri, S., et al., 2021. Effectiveness of Pfizer-BioNTech and Moderna Vaccines in Preventing SARS-CoV-2 Infection Among Nursing Home Residents Before and During Widespread Circulation of the SARS-CoV-2 B.1.617.2 (Delta) Variant — National Healthcare Safety Network, March 1–August. *MMWR. Morbidity and Mortality Weekly Report* 70 (34), 1163–1166. <https://doi.org/10.15585/mmwr.mm7034e3>.
- Nundy, S., et al., 2021. Impact of COVID-19 pandemic on socio-economic, energy-environment and transport sector globally and sustainable development goal (SDG). *Journal of Cleaner Production* 312, 127705. <https://doi.org/10.1016/j.jclepro.2021.127705>.
- Olanrewaju, A.L., et al., 2021. Evaluation of measures to prevent the spread of COVID-19 on the construction sites. *Cleaner Engineering and Technology* 5. <https://doi.org/10.1016/j.clet.2021.100277>.
- Oliva, C., Favato, G., 2022. 'From 15 Minutes to 15 Seconds: How the Delta Variant Changed the Risk of Exposure to COVID-19. A Comparative Epidemiological Investigation Using Community Mobility Data From the Metropolitan Area of Genoa, Italy', *Frontiers. Public Health* 10. <https://doi.org/10.3389/fpubh.2022.872698>.
- Pasco, R.F., et al., 2020. Estimated Association of Construction Work with Risks of COVID-19 Infection and Hospitalization in Texas. *JAMA Network Open* 3 (10), 1–11. <https://doi.org/10.1001/jamanetworkopen.2020.26373>.
- Prem, K., et al., 2020. The effect of control strategies to reduce social mixing on outcomes of the COVID-19 epidemic in Wuhan, China: a modelling study. *The Lancet Public Health* 5 (5), e261–e270. [https://doi.org/10.1016/S2468-2667\(20\)30073-6](https://doi.org/10.1016/S2468-2667(20)30073-6).
- Qiao, Q., Yunusa-Kaltungo, A., 2023. A hybrid agent-based machine learning method for human-centred energy consumption prediction. *Energy and Buildings* 283, 112797. <https://doi.org/10.1016/j.enbuild.2023.112797>.
- Ribeiro, M.H.D.M., et al., 2020. Short-term forecasting COVID-19 cumulative confirmed cases: Perspectives for Brazil. *Chaos, Solitons & Fractals* 135, 109853. <https://doi.org/10.1016/j.chaos.2020.109853>.
- Scobie, H.M. et al. (2021a) 'Monitoring Incidence of COVID-19 Cases, Hospitalizations, and Deaths, by Vaccination Status - 13 U.S. Jurisdictions, April 4–July 17, 2021.', *MMWR. Morbidity and mortality weekly report*, 70(37), pp. 1284–1290. doi: 10.15585/mmwr.mm7037e1.
- Stiles, S., Golightly, D., Ryan, B., 2021. Impact of COVID-19 on health and safety in the construction sector. *Human Factors and Ergonomics In Manufacturing* 31 (4), 425–437. <https://doi.org/10.1002/hfm.20882>.
- Thompson, M.G., et al., 2021. Prevention and Attenuation of Covid-19 with the BNT162b2 and mRNA-1273 Vaccines. *New England Journal of Medicine* 385 (4), 320–329. <https://doi.org/10.1056/nejmoa2107058>.
- Uddin, S., et al., 2023. Title page Road networks to explore COVID-19 infection. Available at: <https://doi.org/10.1101/2023.01.31.23285228>.
- UK Office for National Statistics, 2020. Coronavirus (COVID-19) Infection Survey, UK. *Journal of Chemical Information and Modeling* 43 (1), 25.
- Varotsos, C.A., et al., 2021. COVID-19 pandemic decision support system for a population defense strategy and vaccination effectiveness. *Safety Science* 142. <https://doi.org/10.1016/j.ssci.2021.105370>.
- Varotsos, C.A., Krapivin, V.F., 2020. 'A new model for the spread of COVID-19 and the improvement of safety. *Safety Science* 132. <https://doi.org/10.1016/j.ssci.2020.104962>.
- Varotsos, C.A., Krapivin, V.F., Xue, Y., 2021. 'Diagnostic model for the society safety under COVID-19 pandemic conditions'. *Safety Science* 136. <https://doi.org/10.1016/j.ssci.2021.105164>.
- World Health Organization, 2021. WHO Coronavirus Disease (COVID-19) Dashboard with Vaccination Data | WHO Coronavirus (COVID-19) Dashboard with Vaccination Data. World Health Organization 1–5.
- Xu, J., et al., 2021. Impacts of the COVID-19 Pandemic on construction industry: a comparison between Hong Kong and Singapore Pandemic on construction industry: a comparison between. Springer.
- Yuan, Z., et al., 2022. Effectiveness of Interventions for Controlling COVID-19 Transmission between Construction Workers and Their Close Contacts. *Journal of Management in Engineering* 38 (3), 1–14. [10.1061/\(asce\)me.1943-5479.0001033](https://doi.org/10.1061/(asce)me.1943-5479.0001033).
- Yuan, Z., et al., 2023. Uncovering Construction Site-Specific Transmission Patterns of COVID-19: A Spatiotemporal Connectivity Analysis in Hong Kong. *Journal of Management in Engineering* 39 (1). [https://doi.org/10.1061/\(asce\)me.1943-5479.0001100](https://doi.org/10.1061/(asce)me.1943-5479.0001100).
- Zhang, C., et al., 2021. The role of weather conditions in COVID-19 transmission: A study of a global panel of 1236 regions. *Journal of Cleaner Production* 292, 125987. <https://doi.org/10.1016/j.jclepro.2021.125987>.
- Zhang, N., et al., 2022. An agent-based diffusion model for Residential Photovoltaic deployment in Singapore: Perspective of consumers' behaviour. *Journal of Cleaner Production* 367, 132793. <https://doi.org/10.1016/j.jclepro.2022.132793>.
- Zhao, Y., et al., 2022. Differences in the superspreading potentials of COVID-19 across contact settings. *BMC infectious diseases* 22 (1), 936. <https://doi.org/10.1186/s12879-022-07928-9>.
- World Health Organisation (2023) Advice for the public: Coronavirus disease (COVID-19). Available online at: <https://www.who.int/emergencies/diseases/novel-coronavirus-2019/advice-for-public> (Accessed on 18 March 2023).