

## **An activity-based approach for optimization of land use and transportation network development**

### **Meng Xu**

State Key Laboratory of Rail Traffic Control and Safety  
Beijing Jiaotong University  
No. 3 of Shangyuan Residence, Haidian District, Beijing, 100044, China  
Tel: +86-10-5168-7070  
E-mail: mengxu@bjtu.edu.cn

### **William H.K. Lam**

Department of Civil and Environmental Engineering  
The Hong Kong Polytechnic University  
Hung Hom, Kowloon, Hong Kong, China  
And  
School of Traffic and Transportation  
Beijing Jiaotong University,  
No. 3 of Shangyuan Residence, Haidian District, Beijing, 100044, China  
E-mail: cehklam@polyu.edu.hk

### **Ziyou Gao**

School of Traffic and Transportation  
Beijing Jiaotong University,  
No. 3 of Shangyuan Residence, Haidian District, Beijing, 100044, China  
Tel: +86-10-5168-8193  
E-mail: zygao@bjtu.edu.cn

### **Susan Grant-Muller**

Institute for Transport Studies  
University of Leeds  
34-40 University Road, LS2 9JT Leeds, UK  
Tel: +44 (0)113 34 36618  
E-mail: s.m.grant-muller@leeds.ac.uk

Paper accepted for publication in Transportmetrica B: Transport Dynamics  
23<sup>st</sup> Dec., 2015

**Abstract:**

This paper tentatively makes use of an activity-based approach to investigate the optimization problem of land use allocation and transportation network enhancement, in which the budget for investment and some other constraints are given for the purpose of sustainable urban development. To make investigation on residential and employment development as well as road link capacity expansions for short-term strategic planning purpose, a new bi-level programming model is proposed to capture the interactions between land use and transportation network development together with their impacts on activity-travel choice behaviors. The lower level of the proposed model is used to model the choice behavior of commuters on activity chain, departure time, path and activity scheduling duration simultaneously over the time of day, while the upper level is to maximize the population allocation and network enhancement subject to a set of given constraints. A heuristic solution method is developed to solve the proposed bi-level model. Finally, two numerical examples are presented to demonstrate the application of the proposed model and solution algorithm together with some insightful findings.

**Keywords:** Activity-based approach; land use and transportation network optimization; bi-level programming model; genetic algorithm; sustainable urban development.

## **1. Introduction**

Travel demands are derived from the needs of people for participating in various activities, such as work, eating and shopping over time (Batty, 1976; Recker, 2001; Ouyang, et al., 2011). These activities are also based on temporal and spatial distributions of various land use patterns, and regulatory policies play an important role for the distributions (Xu, Grant-Muller, and Gao, 2015). Land use is related to the interactions among social, ecological and geophysical processes (Munroe and Muller, 2007). The interaction of land use and transportation development has long been regarded as key issue on the sustainable development of land use and transportation system. The future land use pattern is crucial for strategic transportation planning, since it is a prerequisite of the travel demand modeling process, and is the basis of generating socioeconomic and demographic data for transportation planning models (Waddell, 2002; Feng and Hsieh, 2009; Peng, Zhao, and Yang, 2011). On the other hand, the transportation development is based on the land use pattern. The transportation system with various land use patterns is a key factor with respect to accessibility and travel cost, and efficient transportation system is essential to the sustainability and prosperity of modern and urbanized societies (Xu et al., 2015). The improvements of transportation system contribute to the connection of different places between city centers and suburban areas, and would affect the development of Central Business District (CBD) and dwelling areas with different land use patterns. Different scales of cities in a region are involved in an economically hierarchical system. Therefore, without the sustainable development of transportation system and effective land use allocation, it is impossible to maintain an effective urban economy development and a convenient, comfortable urban living.

Although we enjoy the development of the modern transport systems in urban areas, it should not ignore the negative impacts of traffic growth such as traffic congestion, traffic noise, emissions (Grant-Muller and Xu, 2014). An optimal solution cannot be automatically obtained by market mechanism if the transportation system and land use pattern are not planned coherently and efficiently. When users of private cars enjoy the

convenience of transport, they could have not realized what they have caused to the whole society and how much their environmental burdens are. Therefore, it is important to understand the interactions between land use and transportation development with the need of making travel for performing various activities.

The studies of the temporal and spatial interactions between land use allocation and transportation development are essential for urban planning and transportation policy-making. These issues have attracted much attention of many urban planners, transportation engineers and researchers in the past decades (Boyce and Southworth, 1979; Boyce and Xiong, 2007). Integrated Land use allocation and transport optimization models are used to forecast land use responses to change of transportation system. Such models are dynamic in structure, and iterate between alternative transportation systems and land-use schemes. The essence of an integrated land use allocation and transport optimization model is the interaction between land-use and transportation developments. The land use sub-models generate social-economic changes by zones, inputs for the transport model, while the transport model generates accessibility indicators as inputs for the land-use sub-models (Bok, Zondag and Petersen, 2006). For example, Abraham and Hunt (1997) developed a discrete choice model using the random utility theory to describe the interactions between land use allocation and transportation so as to investigate the joint choice of residence and workplace. Yang and Meng (1998) developed a mixed, combined, and stochastic network equilibrium model for urban location and travel choice problems, in which both travel and location choices are based on random utility theory, and thus achieved consistency between location and route choices. Boyce and Mattsson (1999) proposed a bi-level programming approach for the welfare maximization model of a housing location problem. Yang, Bell, and Meng (2000) proposed a bi-level programming approach to a land use and transportation problem, in which the maximum number of trips are generated from each zone and can be accommodated within the road network capacity and zonal capacity. And these trips which are generated from each zone are allocated to various destinations in the network using a joint distribution-assignment

model with variable destination costs. Meng, Yang, and Wong (2000) combined the Lowry model (1964) and network equilibrium model in a multiple period framework, in which the decisions of housing and job location choices are based on the round trip travel time that is experienced at different peak periods. Nagurney and Dong (2002) developed a general, multi-commodity model for a land use and transportation problem, in which zonal travel demand is endogenously determined together with the link congestion cost and optimal amount of production, and the multiclass, multi-criteria housing location and the route choice problem under the influence of advances in telecommunications. Lin and Feng (2003) developed a bi-level programming model for a land use and network design problem, which can consider road types in the integrated sketch layouts of land use, transportation network and public facilities with the use of a combined trip distribution and assignment model on the trip-based approach. Balling, Powell, and Saito (2004) considered the future land use development patterns and transportation plans for high growth cities. Chang and Mackett (2006) proposed a bi-level programming model to approach the interaction between residential location and transportation. Furthermore, Lee, Wu, and Meng (2006) studied the equity issues in land use and transportation development problems. Ying (2007) studied the continuous optimization method for integrated land use and transportation development. Yim et al. (2011) studied a reliability-based land use and transportation optimization problem. More reviews and case studies on this issue can refer to Timmermans (2003), Wegener (2004), Hunt, Miller, and Kriger (2005), Hao, Hatzopoulou, and Miller (2010), and Farooq and Miller (2012).

The literature review provides a framework for us to further investigating the interaction of land use and transportation development, and attempting to gain insights into the long-term effects of changes in the urban land use to the transport system and the impacts of changes in the transportation network to the allocation of population and employment. Previous studies have been devoted to the integration of the travel equilibrium with the land use development. However, little attention has been paid to the optimal residential and employment development and optimal capacity

enhancement by the system allocation, which causes a more comprehensive land use and transportation development plan. It is important to note that the trip-based approach has generally been adopted in most of these studies. The disadvantages and limitations of the trip-based transportation models have been discussed and have been pointed out by researchers, i.e. Boyce and Xiong (2007), Lam and Yin (2001).

Recently, it has known that the activity-based approach provides a better understanding of travel choice behaviors (e.g., departure time, destination, modal and route choices), which are directly motivated by the predetermination of activities such as shopping or recreation (Kitamura, 1988; Lam and Yin, 2001; Recker, 2001; Arentze, and Timmermans, 2003; Hoogendoorn and Bovy, 2004; Lam and Huang, 2003; Recker, Duan, and Wong, 2008). Different the approaches with dynamic user optimum and/or dynamic user equilibrium (Ge and Zhou, 2012; Stewart and Ge, 2014; Ge, et al., 2015), the initial stimulus to the development of travel demand and behaviors analysis based on the activity approach can be traced to critical assessments of both traditional models and emerging behavioral models in the United States in the early of 1970s (Jones, et al., 1983), and the activity framework has provided a new perspective on travel choice behaviors and their analysis. There has been an increasing attention, which has focused on the complex inter-relationships between location and travel choice behaviors (e.g., Williams and Coelho, 1978; Waddell, 2001; Bhat and Koppelman, 1999; Cao, Mokhtarian, and Handy, 2006; Bhat, 2005, 2008; Bhat and Guo, 2007; Pinjari, Bhat, and Hensher, 2009; Ruiz and Roorda, 2011; Wang and Li, 2011). Furthermore, there has been growing number of studies on different transportation network equilibrium models for the travel choice behaviors using activity-based approach rather than trip-based approach (e.g., Lam and Huang, 2002; Timmermans, 2005; Huang and Lam, 2005; Huang, et al., 2005; Li, et al., 2010; Szeto, Jaber, and O'Mahony, 2010; Ouyang, et al., 2011; Fu and Lam, 2014).

Ouyang and Lam (2009) has investigated the joint optimization problem of land use development and transportation network improvement. They proposed a novel bi-level

programming model, in which with the upper level is to determine residential/employment developments and road link capacity expansions with a budget constraint and the lower level is an equivalent network user equilibrium model. An activity-based approach was used to analyze the location choice behavior in the land use model together with their impacts on the transport model. As a result, the user location choice, activity pattern choice and path choice behaviors are modeled with a hierarchical choice structure in which the location choices are firstly made. It follows with the next activity/destination choice and then the path choice finally. In this paper, an activity-based approach will be used to model the activity-travel choice behaviors simultaneously. The interactions between land use allocation and transportation network improvement are approached by a time-dependent activity-based approach to capture the multiple choice behaviors. Using the time-dependent activity-based approach, a bi-level programming model is proposed in this paper to deal with the joint land use and network optimization problem so as to determine simultaneously the residential, employment allocation and network link capacity enhancement for short-term strategic planning purpose (within 5 years). To maintain the sustainable development of the urban system of land use and transportation network, the upper level of the proposed model is to maximize the number of population that could be accommodated with the development of residential and employment allocation and link capacity expansions subjected to a budget constraint. The lower level is an equivalent network equilibrium model to capture the choices of individuals for activity chain, departure time, path and activity schedule duration. These choices will be determined simultaneously based on the network equilibrium condition, as shown in Section 3.1. The combined choices behavior is dependent on the resultant maximum total utility of a typical day with the consideration of various activities and associated travel arrangements. In the proposed bi-level model, the land use allocation and network optimization problem can be considered in a consistent manner to improve the resources allocation of the community in order to maintain the sustainable development.

This paper is organized as follows: In the next section, the basic components of the

proposed model are presented. With the above mentioned benefits of the activity-based approach, In Section 3, a time-dependent activity-based transportation network equilibrium model is firstly formulated. It follows with a new bi-level programming model for the joint optimization problem of land use allocation and transportation network optimization. As a result, the proposed optimization model could capture the interactions between land use and transportation development with their impacts on activity-travel choice behaviors. In Section 4, a genetic-based heuristic algorithm is proposed for solving the bi-level programming problem. Section 5 presents two numerical examples for illustrating the application of the proposed model and solution algorithm. Conclusions are drawn in Section 6 together with recommendations for further studies.

## 2. Basic Considerations

### 2.1 Assumptions and network formulation

To facilitate the presentation of the essential ideas of this paper, the following assumptions are firstly specified.

**A1.**The proposed land use allocation and transportation network model is mainly used for short-term strategic planning purpose. It is assumed that both the original situation and optimal solution would satisfy the location and travel choice equilibrium conditions.

**A2.**The studied time horizon  $T$  is 12 hours from 00:00am to 12:00am, which is divided into equal interval  $t \in T = \{0, 1, \dots, \bar{T}\}$ . For example, the half day is separated into 720 intervals with each one minute.

**A3.**All individuals are assumed to be homogenous in terms of their values of time. They choose their residential location and employment location to obtain the maximum utility by considering the tradeoff between their activities utility obtained and travel disutility.

**A4.** The daily activity-travel schedules of trip-makers involve the following decisions: which trip chain to choose, when to depart from origin (e.g. home), which path to choose, and how long to spend participating in each activity (activity duration).



Trip-makers have their decisions about activities and travel schedules based on a tradeoff between the utility derived from activity participation at different locations and the disutility incurred by journey between activity locations. It is assumed that all individuals in the system are utility-maximizing decision makers and they schedule their activity-travel patterns to maximize their own utility during a day. For simplicity, the set of feasible trip chains and path set is assumed to be pre-specified in this paper.

Consider a network  $G = (N, A)$ , where  $N$  is the set of nodes and  $A$  is the set of links. Let  $H$  be the set of all home-based trip (origin) nodes,  $h$  be an origin of a trip,  $h \in H \subseteq N$ ,  $w$  be a destination of a trip and  $W$  be the set of workplace (destination set),  $w \in W \subseteq N$ . Each trip is associated with a trip chain  $p$ , the trip chain consists of an ordered set of sojourn nodes (i.e. activity nodes)  $i, j$ . Individuals pursue their activities in these sojourn nodes. Let  $I$  denote the set of all activity nodes (or locations), a trip chain  $p$  that traverses a series of nodes can be denoted as  $p = \{h, 2, \dots, i, j, \dots, w\}$ ,  $i, j \in I \subseteq N$ . Let  $P_{hw}$  be the set of all chains from home  $h \in H \subseteq N$  to workplace  $w \in W$ ,  $p \in P_{hw}$ .

A path  $r$  in the network is a sequence of links. Let  $R_{i,j}^p$  be the set of all paths (or links) between activity nodes  $i$  and  $j$  (i.e. both are regarded as a pair of origin and destination nodes. Generally, node  $j$  is the next location of activity  $i$  (node  $i$ )) in trip chain  $p$ ,  $s \in R_{i,j}^p$ , and  $R_{hw}^p$  be the set of all paths in trip chain  $p$ , which starts from home place  $h \in H$  and the final destination is  $w \in W$ .  $R_{hw}^p$  is then the combination of all possible paths between each pair of consecutive activity nodes in the trip chain  $p$ , i.e.  $R_{hw}^p = \{R_{h,2}^p \times \dots \times R_{i,j}^p \dots \times R_{j',w}^p\}$ , where “ $\times$ ” denotes the Cartesian product,  $r \in R_{hw}^p$ .

As an illustration, Figure 1 shows a typical activity case in a small transport network.

There are five nodes (activity locations) in the network: home, recreation, serve passenger, eat meal, work. The activity set  $I = \{h, 2, 3, 4, w\}$ . There are seven home-based trip chains:  $p1$  (“home – eat meal – recreation – work”),  $p2$  (“home – eat meal – serve passenger – work”),  $p3$  (“home –recreation – work”),  $p4$  (“home –serve passenger– work”),  $p5$  (“home –eat meal– work”),  $p6$  (“home– work”). There are different paths for different activity chains, (e.g., path  $r1$  for  $p1$ ,  $r1 = \{1 - 5 - 6\}$ ).

From **A4**, the daily activity-travel schedules of individuals in the network involve the following decisions: which trip chain to choose, which path to choose, when to depart from origin, and how long to perform each activity. Individuals have their decisions about activity and travel schedules based on a tradeoff between the utility derived from activity participation at different locations and the disutility incurred by travel between activity locations. The utility that is gained from an activity depends on the start time of that activity and the duration that it lasts. The activity start time, end time, and activity duration satisfy the following relationship (see Figure 1):

$$\tau_i^E = \tau_i^S + \tau_i, \quad \forall i \in I \quad (1)$$

$$\tau_j^S = \tau_i^E + T_{i,j}, \quad \forall i, j \in I \quad (2)$$

where  $\tau_i^S$  is the start time of activity  $i$ , which is also the arrival time at activity location  $i$ ,  $\tau_i$  is the duration for performing activity  $i$ , and  $\tau_i^E$  is the end time of activity  $i$  (i.e. the departure time from activity location  $i$ ).  $T_{i,j}$  is the travel (or journey) time from activity location  $i$  to activity location  $j$  (the next activity location  $i$ ). For ease of presentation, we define an activity schedule pattern as all possible combinations of activity start time, activity duration, and activity end time, which is denoted as  $\boldsymbol{\tau} = \{\tau_i^S, \tau_i, \tau_i^E, \forall i \in I\}$ , and define  $\Theta$  as the set of all activity schedule patterns in the network.

## 2.2 Utility of path in trip chain

Let  $U_r^p(t, \boldsymbol{\tau})$  be the utility of using path  $r \in R_{hw}^p$  on the chain  $p \in P_{hw}$ , departure at time  $t$  and activity schedule pattern  $\boldsymbol{\tau}$ . It is the difference between the total utility

derived from all instances of activity participation along the chain minus the total disutility of travel along the chain, that is, for  $\forall r \in R_{hw}^p, s \in R_{i,j}^p, p \in P_{hw}, h \in H, w \in W, t \in T, \tau \in \Theta$ ,

$$U_r^p(t, \tau) = \sum_{i \in I} U_i(\tau_i^S, \tau_i) \delta_{ip} - \sum_{i \in I} C_s(\tau_i^E) \delta_{s,r}^p, \quad (3)$$

Where  $U_i(\tau_i^S, \tau_i)$  is the utility achieved by a commuter performing activity  $i$  at time  $\tau_i^S$  for duration  $\tau_i$ .  $\delta_{ip}$  equals 1 if activity location  $i$  is on chain  $p$ , and 0 otherwise.  $C_s(\tau_i^E)$  is the disutility of traveling along path sections from activity location  $i$  at interval  $\tau_i^E$  (i.e. activity  $i$ 's end time  $\tau_i^E = \tau_i^S + \tau_i$ ) to activity location  $j$  on chain  $p$ .  $\delta_{s,r}^p$  equals 1 if path  $s$  between activity nodes  $i$  and  $j$  on trip chain  $p$  is a part of path  $r$  on trip chain  $p$ , and 0 otherwise. The utility of activity and the disutility of travel will be defined as below.

### 2.3. Utility of activity

Generally, it is assumed that individuals gain utility or benefits from taking part in an activity are dependent on the start time and duration of the activity. Let  $MU_i(x)$  denote the marginal utility of activity  $i$  that is gained from participation in one time unit of activity  $i$  at time  $x$ . Thus, the utility achieved by a commuter performing activity  $i$  with start time  $t$  and duration  $\tau_i$  can be defined as

$$U_i(t, \tau_i) = \int_t^{t+\tau_i} MU_i(x) dx, \quad \forall \tau_i, i \in I, t \in T. \quad (4)$$

The marginal utility of activity  $i$ ,  $MU_i(x)$ , can be measured by the following bell-shaped marginal utility function (Joh, Arentze, and Timmermans, (2002), Li et al. (2010))

$$MU_i(x) = U_i^0 + \frac{\rho_i \lambda_i U_i^{max}}{\exp(\rho_i(x-\xi_i))(1+\exp(-\rho_i(x-\xi_i)))^{\lambda_i+1}}, \quad \forall i \in I, \quad (5)$$

Where  $U_i^0$  is the baseline utility level of activity  $i$ .  $U_i^{max}$  is the maximum utility of activity  $i$ , and  $\rho_i$ ,  $\lambda_i$  and  $\xi_i$  are activity-specific parameters, which  $\rho_i$  determines the slope or steepness of the curve,  $\lambda_i$  determines the relative position of the inflection

point, and the parameter  $\xi_i$  determines the time of day at which the marginal utility reaches its maximum value. These parameters can be estimated based on survey data.

#### 2.4 Travel disutility

We now define the travel disutility,  $C_s(t)$ ,  $s \in R_{i,j}^p$ , of commuters who depart from activity location  $i$  at time  $t$  to activity location  $j$  along path  $s$  in the trip chain  $p$ . It consists of the travel time cost on the road and the operating cost (fuel cost) of the vehicles, i.e.,

$$C_s(t) = \alpha_1 T_s(t) + \Phi_s, \forall s \in R_{i,j}^p, i \in I, t \in T, \quad (6)$$

where  $\alpha_1$  is the commuter's value of travel time, which is used to convert travel time into equivalent monetary units.  $T_s(t)$  is the travel time of commuters departing from activity location  $i$  at interval  $t$  to activity location  $j$  along path  $s$  in trip chain  $p$ .  $\Phi_s$  is the fuel cost of path  $s$  from activity location  $i$  to activity location  $j$  in trip chain  $p$ , which is measured in terms of monetary units. It is assumed that  $\Phi_s$  is a linear function of the distance traveled, and thus not related to the departure time interval (Liu, et al., 2009).

Travel time  $T_s(t)$  in Equation (6) can be calculated by

$$T_s(t) = \sum_{a \in A} \sum_{k \geq t} T_a(k) \delta_{at}^s(k), \forall s \in R_{i,j}^p, i \in I, t \in T, \quad (7)$$

where  $T_a(k)$  is the travel time of commuters on link  $a$  during interval  $k$ .  $\delta_{at}^s(k)$  equals to 1 if the commuter departing from activity location  $i$  at interval  $t$  to activity location  $j$  via path  $s$  and arriving link  $a$  at interval  $k$ , and 0 otherwise.

The link travel time experienced by commuters who enter link  $a$  during interval  $k$  can be expressed as a function of all inflows entering that link by interval  $k$  (Chen and Hsueh, 1998; Chen, 1999; Lam et al., 2006), i.e.,

$$T_a(k) = f(v_a(1), v_a(2), \dots, v_a(k)), \forall a \in A, k \in T, \quad (8)$$

Where  $v_a(k)$  is the inflow that commuters enter link  $a$  during interval  $k$ , which is

given by

$$v_a(k) = \sum_{i \in I} \sum_{s \in R_{i,j}^p} \sum_{t \in T} v_{a,s,t}(k), \quad \forall a \in A, k \in T, \quad (9)$$

where  $v_{a,s,t}(k)$  is the inflow to link  $a$  during interval  $k$  that departs from location  $i$  at interval  $t$  to location  $j$  along path  $s$ , which can be determined in terms of path inflows as follows:

$$v_{a,s,t}(k) = f_s(t) \delta_{at}^s(k), \quad \forall a \in A, s \in R_{i,j}^p, i \in I, t \in T, k \in T, \quad (10)$$

where  $f_s(t)$  is the path inflow who departs from location  $i$  at interval  $t$  to location  $j$  via path  $s$ , which can be given by

$$f_s(t) = \sum_{h \in H} \sum_{p \in P_{hw}} \sum_{r \in R_{hw}^p} \sum_{k \in T} q_r^p(k) \delta_{sk}^r(t), \quad \forall s \in R_{i,j}^p, i \in I, t \in T, \quad (11)$$

where  $q_r^p(k)$  is the travel demand departing at interval  $k$  and using path  $r$  in chain  $p$ .  $\delta_{sk}^r(t)$  equals 1 if the commuters departing from origin  $h$  along path  $r$  in chain  $p$  at interval  $k$  entering path  $s$  between location  $i$  and location  $j$  at interval  $t$ , and 0 otherwise.  $q_r^p(k)$  can be represented as

$$q_r^p(k) = \sum_{\tau \in \Theta} q_r^p(k, \tau), \quad \forall r \in R_{hw}^p, p \in P_{hw}, h \in H, k \in T, \quad (12)$$

where  $q_r^p(k, \tau)$  is the travel demand departing at interval  $k$  from origin  $h$  along path  $r$  in chain  $p$  with activity schedule pattern  $\tau$ .

The fuel cost,  $\Phi_s$ , from activity location  $i$  to activity location  $j$  along path  $s$  is a linear function of the distance traveled (Liu, et al., 2009), i.e.

$$\Phi_s = \eta_0 \phi D_s, \quad \forall s \in R_{i,j}^p, i \in I, p \in P_{hw}, \quad (13)$$

where  $\eta_0$  is the unit price of fuel consumption, and  $\phi$  is the fuel consumption of auto per kilometer.  $D_s$  is the length of path  $s$  between activity locations  $i$  and  $j$  in the trip chain  $p$ , which is expressed as

$$D_s = \sum_{a \in S} D_a \delta_a^s, \quad \forall s \in R_{i,j}^p, i \in I, \quad (14)$$

Where  $\delta_a^s$  equals 1 if link  $a$  on path  $s$  between location  $i$  and location  $j$ , and 0 otherwise.

### 3. Model Formation

#### 3.1 Time-dependent activity-based transportation network equilibrium

According to **A4**, each individual in the network schedules his/her activity-travel pattern to maximize his/her utility during a day. This leads to a time-dependent Wardrop's user equilibrium of joint choices of trip chain, departure time, path, and activity duration.

**Definition 1.** At equilibrium, for all the given home-work activity patterns, the utility of all of the used combinations of activity chain, departure time, path and activity schedule duration are equal and maximal, and the utility of any unused combination of trip chain, departure time, path, and activity schedule duration is smaller than or equal to the maximum.

Definition 1 means that for a given home-work activity pattern, no individual would be better off by unilaterally changing his/her trip chain, departure time, path and activity schedule duration. The activity scheduling equilibrium can mathematically be expressed in a complementary form. That is, for  $\forall r \in R_{hw}^p$ ,  $p \in P_{hw}$ ,  $h \in H$ ,  $w \in W$ ,  $t \in T$ ,  $\tau \in \Theta$ ,

$$(U_r^{p*}(t, \tau) - U_{hw}^{max})q_r^{p*}(t, \tau) = 0, \quad (15)$$

$$U_r^{p*}(t, \tau) \leq U_{hw}^{max}, \quad (16)$$

$$U_{hw}^{max} = \max\{U_r^{p*}(t, \tau), \forall r, p, t, \tau\}, \quad (17)$$

$$q_r^{p*}(t, \tau) \geq 0, \quad (18)$$

where the superscript “\*” represents the equilibrium state, and  $U_{hw}^{max}$  is the maximal utility received by individuals with home-work activity pattern ( $h - w$ ).

The following proposition shows that above activity-travel scheduling equilibrium conditions (15)-(18) is in fact equivalent to a variational inequality (VI) problem.

**Proposition 1.** A time-dependent travel demand pattern  $\{q_r^{p*}(t, \tau)\}$  in the context of daily activity-travel schedules reaches an equilibrium state if and only if it solves the

following VI problem:

For  $\forall q_r^p(t, \tau) \in \Omega$ ,

$$\sum_{h \in H} \sum_{w \in W} \sum_{p \in P_{hw}} \sum_{r \in R_{hw}^p} \sum_{\tau \in \Theta} \sum_{t \in T} U_r^{p*}(t, \tau) \left( q_r^p(t, \tau) - q_r^{p*}(t, \tau) \right) \leq 0, \quad (19)$$

where the variables with asterisks(‘\*’) in the above VI represent the optimal solutions,  $\Omega$  is the feasible set of home-work activity pattern, which is defined as

$$\sum_{w \in W} \sum_{p \in P_{hw}} \sum_{r \in R_{hw}^p} \sum_{\tau \in \Theta} \sum_{t \in T} q_r^p(t, \tau) = q_h, \forall h \in H; \quad (20)$$

$$\sum_{h \in H} \sum_{p \in P_{hw}} \sum_{r \in R_{hw}^p} \sum_{\tau \in \Theta} \sum_{t \in T} q_r^p(t, \tau) = q_w, \forall w \in W; \quad (21)$$

$$\sum_{h \in H} q_h = \sum_{w \in W} q_w = Q; \quad (22)$$

$$q_r^p(t, \tau) \geq 0, \forall r \in R_{hw}^p, s \in R_{i,j}^p, p \in P_{hw}, h \in H, w \in W, t \in T, \tau \in \Theta. \quad (23)$$

$$\Omega = \{q_r^p(t, \tau) | (20) - (23)\} \quad (24)$$

where  $q_h$  is the total population at home  $h \in H$ ,  $q_w$  is the total population at work place  $w \in W$ .

**Theorem 1:** The path-based VI Problem (19)-(24) is equivalent to the activity scheduling equilibrium conditions (15)-(18).

**Proof:** The idea of this proof is similar as given in Frieszet al. (1993) and Chen (1999).

Define a feasible solution  $\{q_r^p(t, \tau)\}$  to be the same as the equilibrium flow pattern

$\{q_r^{p*}(t, \tau)\}$ , except for two path  $r_1 \in R_{hw}^p$  during interval  $t_1$  with trip chain  $p_1 \in P_{hw}$

and activity schedule duration  $\tau_1$ , and  $r_2 \in R_{hw}^p$  during interval  $t_2$  with trip chain

$p_2 \in P_{hw}$  and activity schedule duration  $\tau_2$ . Without loss of generality, we consider

two situations that could appear at equilibrium:

(i) Both travel demand are positive, i.e.,  $q_{r_1}^{p_1*}(t_1, \tau_1) > 0$ , and  $q_{r_2}^{p_2*}(t_2, \tau_2) > 0$ . We switch a small amount of travel demand  $\Delta_1$  from path  $r_1$  to  $r_2$ , where  $0 \leq \Delta_1 \leq q_{r_1}^{p_1*}(t_1, \tau_1)$ . That is,

$$q_{r_1}^{p_1}(t_1, \tau_1) = q_{r_1}^{p_1*}(t_1, \tau_1) - \Delta_1 \quad \text{and} \quad q_{r_2}^{p_2}(t_2, \tau_2) = q_{r_2}^{p_2*}(t_2, \tau_2) + \Delta_1.$$

By substituting the two new feasible solutions into the VI formulation (19), we have:

$$U_{r_1}^{p_1^*}(t_1, \boldsymbol{\tau}_1) \left( q_{r_1}^{p_1}(t_1, \boldsymbol{\tau}_1) - q_{r_1}^{p_1^*}(t_1, \boldsymbol{\tau}_1) \right) + U_{r_2}^{p_2^*}(t_2, \boldsymbol{\tau}_2) \left( q_{r_2}^{p_2}(t_2, \boldsymbol{\tau}_2) - q_{r_2}^{p_2^*}(t_2, \boldsymbol{\tau}_2) \right) \leq 0 \quad (25)$$

Therefore,

$$U_{r_1}^{p_1^*}(t_1, \boldsymbol{\tau}_1) \geq U_{r_2}^{p_2^*}(t_2, \boldsymbol{\tau}_2) \quad (26)$$

Similarly, by switching a small amount of flow  $\Delta_2$  from path  $r_2$  to  $r_1$  with  $0 \leq \Delta_2 \leq q_{r_2}^{p_2^*}(t_2, \boldsymbol{\tau}_2)$ , we obtain

$$U_{r_1}^{p_1^*}(t_1, \boldsymbol{\tau}_1) \leq U_{r_2}^{p_2^*}(t_2, \boldsymbol{\tau}_2) \quad (27)$$

Combination of the two inequalities imply:

$$U_{r_1}^{p_1^*}(t_1, \boldsymbol{\tau}_1) = U_{r_2}^{p_2^*}(t_2, \boldsymbol{\tau}_2) \quad (28)$$

We can repeat this procedure to verify that positive travel demand with all used activity chain with different activity pattern and with all used paths have the same actual utility.

**(ii)** One travel demand is positive and the other travel demand is nil, e.g.,  $q_{r_1}^{p_1^*}(t_1, \boldsymbol{\tau}_1) > 0$ , and  $q_{r_2}^{p_2^*}(t_2, \boldsymbol{\tau}_2) = 0$ . We switch a small amount of flow  $\Delta_1$  from path  $r_1$  to  $r_2$ , where  $0 \leq \Delta_1 \leq q_{r_1}^{p_1^*}(t_1, \boldsymbol{\tau}_1)$ . By the same argument shown in (i), we have  $U_{r_1}^{p_1^*}(t_1, \boldsymbol{\tau}_1) \geq U_{r_2}^{p_2^*}(t_2, \boldsymbol{\tau}_2)$ . We can repeat this procedure to verify for each activity chain with different activity pattern that all unused paths with zero flow will have an actual utility no higher than the maximal actual utility.

Since both (i) and (ii) must hold, it follows that the VI problem (19)-(24) implies equilibrium conditions

$$U_r^{p^*}(t, \boldsymbol{\tau}) \begin{cases} = U_{hw}^{max} & \text{if } q_r^{p^*}(t, \boldsymbol{\tau}) > 0 \\ \geq U_{hw}^{max} & \text{if } q_r^{p^*}(t, \boldsymbol{\tau}) = 0 \end{cases}, \forall r \in R_{hw}^p, p \in P_{hw}, h \in H, w \in W, t \in T, \boldsymbol{\tau} \in \Theta \quad (29)$$

The equilibrium conditions are equivalent to the complementary form given in (15)-(18).

From the Proposition 1 and Theorem 1, we have shown that the VI problem (19)-(24) indeed reproduces the activity scheduling equilibrium conditions (15)-(18). The VI



problem (19)-(24) is path-based and path set is given in the solution algorithm. The path travel disutility functions defined in Section 2.4 are non-linear and non-convex with respect to path flow (Sheffi, 1985; Huang and Lam, 2002; Xu and Gao, 2009). VI (19)-(24) is thus non-convex, and multiple local solutions could exist.

### 3.2 An optimization model for land use allocation and transportation optimization

In this section, a bi-level programming model is proposed that integrates the land use allocation including the residential and employment allocations and link capacity enhancement. The upper level problem is to maximize the allocated population with the budget and some other physical resource constraints. We need the activity chain, departure time, path and activity schedule duration information of individuals, which can be determined by the lower-level subprogram with an activity scheduling equilibrium approach as shown in Section 3.1. It is noted that the lower-level model is a class of dynamic network flow model to approach the multiple choice behaviors, which is respond to obtaining of the maximum total utility in a typical day. The utility definition for an activity pattern is given in Equation (3). Comparing with existing trip-based model, e.g., the classical UE based network equilibrium model, the presented utility based model provides an approach to the different activities choice clearly. Therefore, different with existing approaches, the proposed bi-level programming model, with the determination of population allocation and transport network enhancement for the strategic development purpose in upper level model and the multiple travel choice behaviors model with the dynamic network flow approach in lower level model, provides a connection between regional development planning optimization and dynamic multiple travel choices adjustment.

We have the following bi-level optimization model:

#### **Upper-level problem:**

$$\text{Maximize } Q(\mathbf{M}_h, \mathbf{M}_w, \mathbf{L}) \quad (30)$$

*s. t.*

$$\sum_{h \in H} A_h(M_h) + \sum_{w \in W} A_w(M_w) + \sum_{a \in A} B_a(L_a) \leq B; \quad (31)$$

$$\sum_{h \in H} M_h = \sum_{w \in W} M_w = Z; \quad (32)$$

$$M_h \geq 0, \forall h \in H; \quad (33)$$

$$M_w \geq 0, \forall w \in W; \quad (34)$$

$$0 \leq L_a \leq L_a^{max}, \forall a \in A; \quad (35)$$

$$q_h = \bar{q}_h + M_h, \forall h \in H; \quad (36)$$

$$q_w = \bar{q}_w + M_w, \forall w \in W; \quad (37)$$

$$\sum_{h \in H} q_h = \sum_{w \in W} q_w = Q; \quad (38)$$

$$\sum_{h \in H} \bar{q}_h = \sum_{w \in W} \bar{q}_w = \bar{Q}; \quad (39)$$

$$\sum_{h \in H} M_h = \sum_{w \in W} M_w = \Delta Q; \quad (40)$$

$$Q = \bar{Q} + \Delta Q; \quad (41)$$

where the definition of  $A_h(M_h), A_w(M_w)$  are separately the cost of residential development on  $h$  and employment development on  $w$ , which is the function of residence allocation  $M_h$  and employment allocation  $M_w$  respectively,  $B_a(L_a)$  is the cost of capacity enhancement on link  $a$ , which is the function of link capacity enhancement  $L_a$ , the  $\bar{q}_h, q_h$  are the original population and potential population development at residential location  $h$ , the  $\bar{q}_w, q_w$  are the original population and potential population development at employment location  $w$ ,  $Q, \bar{Q}, \Delta Q$  are respectively the total population, original population and potential population development,  $B$  is the given total budget, and  $Z$  is the maximal development potential of population.

The potential population development at residence and workplace  $q_h, q_w$  can be determined by solving the lower-level VI formulation.

#### Lower-level problem:

$$\sum_{h \in H} \sum_{w \in W} \sum_{p \in P_{hw}} \sum_{r \in R_{hw}^p} \sum_{\tau \in \Theta} \sum_{t \in T} U_r^{p*}(t, \tau) \left( q_r^p(t, \tau) - q_r^{p*}(t, \tau) \right) \leq 0. \quad (42)$$

The  $q_r^p(t, \tau)$  in above VI formulation is given in  $\Omega$  ( $\forall q_r^p(t, \tau) \in \Omega$ ) and  $\Omega$  is determined as in set (24).

The optimization model is actually a bi-level mathematical programming problem with a VI constraint (or a mathematical programming with equilibrium constraints). It is intrinsically non-convex and hence it might be difficult to solve for a global optimum, and difficult to guarantee their solutions are “true solutions” for time-varying traffic flows. An initial heuristic solution algorithm is discussed in the next section.

#### **4. Solution Algorithm: A Genetic Algorithm (GA) based Approach**

Bi-level problems are generally difficult to solve because the evaluation of the upper-level objective function/constraints requires the solution of the lower-level subprogram. To solve the proposed combined land use and transportation network optimization problem, a GA based solution procedure that embeds the modified projection method to solve traffic assignment problem (Chen, 1999) is developed. The modified projection method is extended to solve the activity and travel choice equilibrium problem (42), and a GA is used to determine a near-optimal residential allocation, employment allocation, and capacity enhancement in the upper-level subprogram. In the GA based solution procedure, the evaluation of the fitness of each solution (i.e., residential (home) and employment (work) allocation, and capacity enhancement) requires the solution of the lower-level subprogram. The details of these two algorithms are described as follows.

##### **4.1. The modified projection method for solving the lower-level optimal problem**

To solve the lower-level VI problem (42) of the bilevel program formulated above, we may choose different approaches, e.g., general iterative algorithm, projection method, and modified projection method. Note that a necessary condition for convergence of the general iterative algorithm is that the utility item  $U_r^p(t, \boldsymbol{\tau})$  is strictly monotone (Chen, 1999); however, this requirement is not met in the problem under investigation. Here we use a heuristic, modified projection method to solve the time-dependent activity and travel choice equilibrium problem (42).

Step 0. Initialization. Choose initial values for activity pattern  $\mathbf{q}^{(0)} = \{q_r^{p(0)}(t, \boldsymbol{\tau})\}$ .

Set iteration counter  $n = 0$ , and select  $\sigma$ , such that  $0 < \sigma < \frac{1}{l}$ , where  $l$  is the Lipschitz constant for utility function  $U_r^p(t, \boldsymbol{\tau})$  in the VI problem (42) and setting  $l = 0.5$ .

Step 1. Construction and Computation. Compute  $\bar{\mathbf{q}}^{(n)}$  by solving the VI subproblem:

$$[\bar{\mathbf{q}}^{(n)} + (\sigma \mathbf{U}^{(n)}(\mathbf{q}^{(n)}) - \mathbf{q}^{(n)})](\mathbf{q}' - \bar{\mathbf{q}}^{(n)}) \leq 0, \quad \forall \mathbf{q}' \in \Omega, \quad \text{where}$$

$$\mathbf{U}^{(n)}(\mathbf{q}^{(n)}) = \{U_r^{p(n)}(t, \boldsymbol{\tau}, \mathbf{q}^{(n)})\}.$$

Step 2. Adaptation. Compute  $\mathbf{q}^{(n+1)}$  by solving the VI problem:

$$[\mathbf{q}^{(n+1)} + (\sigma \mathbf{U}^{(n)}(\bar{\mathbf{q}}^{(n)}) - \mathbf{q}^{(n)})](\mathbf{q}' - \mathbf{q}^{(n)}) \leq 0, \quad \forall \mathbf{q}' \in \Omega$$

Step 3. Convergence check. If the gap,  $|\mathbf{q}^{(n+1)} - \mathbf{q}^{(n)}| \leq \varepsilon$ ,

is smaller than a pre-specified tolerance, then stop. Otherwise, set  $n = n + 1$  and go to Step 1.

In Step 0, the initial travel demand pattern can be set to the original travel demand  $(\bar{q}_h, \bar{q}_w, \bar{Q})$ . In Step 1, solving the VI problem can refer to Ran and Boyce (1996) and Chen (1999), there is also possible to solve it with the concept of tolerance-based DUO (Ge, et al., 2015).

#### 4.2. Computing land use allocations and capacity enhancement

Many heuristic algorithms have been developed to solve the bi-level programming problem (see Yang and Bell (1998) for a summary survey). Due to the non-convex nature of the bi-level program, it is difficult to guarantee that the resultant solution will be globally optimal because the activity pattern are generally non-convex and continuous, but non-differentiable functions with respect to the upper-level variables  $(\mathbf{M}_h, \mathbf{M}_w$  and  $\mathbf{L})$ . In view of this difficulty, the genetic algorithm is used to solve the land use allocation and transportation optimization model.

GA is a global search heuristic technique used to find true or approximate solutions to optimization problems (Ge, Zhang, and Lam, 2003; Zhang and Ge, 2004; Balling,

Powell, and Saito, 2004; Wong, Wong, and Tong, 1998; Yang, 2008; Yim et al., 2011). It consists of techniques including inheritance, mutation, selection and crossover, which are inspired by evolutionary biology. GA is implemented as a computer simulation in which a population of chromosomes of candidate solutions to an optimization problem evolves toward better solutions. Solutions can be represented in binary or real-coded. The evolution usually starts from a population of randomly generated individuals and happens in generations. In each generation, the fitness value of every individual in the population is evaluated, multiple individuals are randomly selected from the current population (based on their fitness value) and modified (recombined and possibly randomly mutated) to form a new population. The new population is then used in the next iteration of the algorithm. Commonly, the algorithm terminates when either a maximum number of generations arrived, or a satisfactory fitness value reached for the population.

We firstly define the fitness value, individual and GA operators that used to solve the bi-level model.

**Fitness value:** the fitness value can use the upper object function in the bi-level programming model.

**Individual:** coding the individual with real number, the benefit of using real number is that it can show the individual characters directly. The  $m$ -th gene represent the residential and employment development and the enhancement of link capacity of the  $m$ -th individual. The length of the individual is equal to the number of residence and workplace and links that need to improve the network.

**GA operators:** The sets of GA operators include choice strategy, crossover strategy and mutation strategy.

**Choice strategy:** Order the fitness value of each individual in the population size, and the individual with the least fitness value has the largest choice probability, which can guarantee the convergence level of the solution, and set the fixed choice probability

**Crossover strategy:** Choose randomly two individuals from the population size and carry out crossover operate to the two individuals, and set the crossover probability.

Mutation strategy: Take the mutation operate to one of the gene in the individual and generate new individual.

The overall real-coded genetic algorithm scheme to solve the bi-level model is summarized as follows:

Step 0: Initialization.

0.1 Define the parameters for the GA. Including the population size, crossover rate, mutation rate, and the maximum number of generations.

0.2 Generate an initial random population of chromosomes. Initialize the individual solutions, and they are represented by chromosomes of the population. Set the iteration number  $n=0$ .

Step 1: Evaluate the fitness value of each chromosome in the population by solving the lower-level problem (See Section 4.1), and calculate the upper object function value, which is regarded as fitness scale of each chromosome.

Step 2: Order the fitness value from the least to the largest.

2.1 The least fitness scale corresponds to the maximal choice probability, and the largest fitness scale corresponds to the least choice probability, where the choice probability is fixed. The local optimal solution (the minimize fitness value) can be identify from current population.

2.2 Choose individual and generate new individuals with loops.

Step 3: Crossover. Generate new offspring by exchange of information between the individuals, which generate in Step 2.2. Implement the crossover process if necessary.

Step 4: Mutation. Implement the mutation process if necessary.

Step 5: Stop if the maximum iteration arrived; otherwise, return to Step 1 and set  $n = n + 1$ .

Considering the complexity of the models, above algorithm provides only an approach to simple network case. Further studies of the algorithm are necessary for large-scale network and complex case.

## 5. Numerical Examples

### 5.1. Problem description and parameters setting

Consider a network consists of four nodes, seven links, and including one residence and one workplace, as shown in Figure 2. Following Chen and Hsueh (1998), Lam and Yin (2001), and Lam et al. (2006), the link travel time  $T_a(t)$  on link a can be computed by the following Bureau of Public Roads (BPR) function:

$$T_a(t) = T_a^0 \left[ 1 + 0.15 \left( \frac{v_a(t)}{C_a} \right)^4 \right], \forall a \in A, t \in T, \quad (43)$$

Where  $T_a^0$  is the free-flow travel time on link a, and  $C_a$  is the capacity of link a with respect to Passenger Car Unit (pcu) (pcu/hour). The input data for the link travel time functions are shown in Table 1.

It is assumed that the total number of trip-makers originating from home location is 2000 units of population ( $\bar{Q} = 2000$ ). The baseline price level per unit of fuel consumption  $\eta_0$  is CNY 8.0 per liter (“CNY” is the unit of the Chinese currency “yuan”), and the fuel consumption  $\phi = 0.092$  liter/pcu/km.

The activities concerned  $I = \{h, 2, 3, w\}$ : Activity (location, node)  $h$ : Home; Activity (location, node) 2: Eat meal; Activity (location, node) 3: Serve passenger; Activity (location, node)  $w$ : Work. The input parameters for the marginal utility functions of these four activities are shown in Table 2. The associated marginal utility curves are plotted in Figure 3. There are four home-based trip chains pattern, that is, the activity chain set  $P_{hw} = \{p1, p2, p3, p4\}$ ;  $p1 = \{h, 2, 3, w\}$  (“home – eat meal – serve passenger – work”);  $p2 = \{h, 2, w\}$  (“home – eat meal – work”);  $p3 = \{h, 3, w\}$  (“home – serve passenger – work”);  $p4 = \{h, w\}$  (“home – work”). The path set of different activity chains is  $R_{h,w}^{p1} = \{R_{h,2}^{p1} \times R_{2,3}^{p1} \times R_{3,w}^{p1}\} = \{r1: 3 - 5 - 4\}$ ;  $R_{h,w}^{p2} = \{R_{h,2}^{p2} \times R_{2,w}^{p2}\} = \{r2: 3 - 6\}$ ;  $R_{h,w}^{p3} = \{R_{h,3}^{p3} \times R_{3,w}^{p3}\} = \{r3: 1 - 4\}$ ;  $R_{h,w}^{p4} = \{r4: 2; r4: 7\}$ .

The capacity of the network links is allowed to expand up to 20 percent of the existed

link capacity, that is,  $L_a^{max} = 0.2C_a, \forall a \in A$ . The budget for network capacity expansion is given by  $\sum_{a \in A} B_a(L_a) = \sum_{a=1}^7 0.3L_a^2$ . Suppose that there are 20 percent units of population growth ( $\Delta Q = 400$ ), which requires the land use development to residents and employment in the city and setting the maximal units of population development potential  $Z = 400$ . The costs of the residential and the employment developments are  $\sum_{h \in H} A_h(M_h) = M_h^2$  and  $\sum_{w \in W} A_w(M_w) = M_w^2$  respectively, in which  $0 \leq M_h \leq 400$  represents the residential development in zone  $h \in H$ , and  $0 \leq M_w \leq 400$  represents the employment development in zone  $w \in W$ . The maximum budget for the land use development and the network capacity enhancement is CNY 368000 thousand (0.368 billion CNY). Hence, we have  $M_h^2 + M_w^2 + \sum_{a=1}^7 0.3L_a^2 \leq 368000$ .

This example was conducted with double precision arithmetic on an Intel(R) Core (TM) i5-3230M CPU@2.60 GHz, 2.60 GHz RAM, using the Microsoft Windows 7 Enterprise operating system. All of the coding was carried out using Matlab R2013a.

## 5.2. Numerical results and discussion

The values of the numerical example solution are shown in Table 3, which includes the total population, original population, increased population, total budget, residential and employment expansion, link capacity expansion, the travel demand for different activity chains, and the average durations for different activities (including stay at home, eat meal, serve passenger, and work) when the combined equilibrium conditions are satisfied. Although the original link capacity for the total seven links on the network is assumed the same (2000 pcu/hour), the link capacity enhancement are different with the budget constraint, the main link capacity expansion is conducted on link 2 and link 7, which is directly connect the home and work (with the activity pattern  $p4$ ) with the higher travel demand (the travel demand of activity pattern  $p4$  is 220 units of population, which cover 55% of the increased units of population 400). There are corresponding different increases on links 1,3,4,6 based on the activity patterns and there is no capacity on link 5 since the existed link capacity on the link satisfies the



travel demand between activity 2 and activity 3. Table 3 also shows the average duration on different activities in the study horizon that is from 00:00am to 12:00am. The average duration of staying at home is 7.5 hours, the average eating duration (breakfast outside the home) is 0.25 hours (15 minutes), the average serve passenger duration is 0.45 hours (27 minutes), and the average work duration is 3.8 hours to the end of 12:00am. The average duration of different activity shows the times use of individuals and their time allocations on different activities.

Figure 4 shows that the maximum additional population improvement that are accommodated without decreasing users' utility with the equilibrium formulation (42) which rises with the increase of budget level. It can be explained that the increase in the budget level with effective arrangement is able to substantially change the activity pattern of individuals, which works favorably with the network expansion to support the sustainable development of the network. It also needs to point out that the slope of the curve in Figure 4 decreases with the increase of the budget level, which demonstrates that the marginal cost for allocating increased population does not decrease with the increase of population.

### 5.3. Another large numerical example

To demonstrate the effectiveness of the proposed model and solution method, we reset a classical example used in transport network analysis. As shown in Figure 5, the network consists of 13 nodes, 23 links and 4 OD pairs ((1, 2), (1, 3), (4, 2), (4, 3)). The link travel time function has the following structure

$$T_a(t) = T_a^0 \left[ 1 + T_a^1 \left( \frac{v_a(t)}{c_a} \right)^{T_a^2} \right], \forall a \in A, t \in T, \quad (44)$$

The link characteristics of the Figure 5 are listed in Table 4, where  $T_a^1$  and  $T_a^2$  are parameters.

Assuming the currently units of population in the two home locations are  $\bar{Q}_1 = 3300$ ,  $\bar{Q}_4 = 2200$ . The 13 nodes are respond to different activities node set  $I =$

$\{h1, h2, em1, sp1 - sp3, oa1 - oa5, w1, w2\}$ , which “ $h1, h2$ ” means two home zones, zone 1 and home zone 2, “ $em1$ ” means one meal eating zone, “ $sp1 - sp3$ ” means 3 passenger severing zones,  $sp1, sp2, sp3$ . “ $oa1 - oa5$ ” means 5 other activities zones,  $oa1, oa2, oa3, oa4, oa5$ . We assume the associated marginal utility curves as shown in Figure 3, where the associated marginal utilities in 3 passenger severing zones are same, and the marginal utilities in 5 other activities zones are same and equals to constant. The travel demands of the four OD pairs are fixed (unit: pcu), that is,  $\bar{Q}_{12} = 800, \bar{Q}_{13} = 2500, \bar{Q}_{42} = 1400, \bar{Q}_{43} = 800$ . The capacity of the network links is allowed to expand to 100% of the existed link capacity, and the budget function is the same as in Section 5.2. We assume the units of population growth scheme is  $\Delta Q_1 = 300$  and  $\Delta Q_4 = 200$ . The costs of the residential and the employment developments are the same as in Section 5.1.

With the above settings of Figure 5, Table 5 and Table 6 demonstrate the trip pattern and land use development pattern. The genetic-based algorithm can lead to the optimal solution, and determine the optimal residential and employment allocation and road link capacity enhancement scheme. It is noted that the main trips have focused on the home-work pattern for each OD pair. This depends on the settings of the links cost function, and the utilities of involved activities (each nodes). To focus on the main effects of cost function, the settings of the severing passenger activities ( $sp1 - sp3$ ) and other activities ( $oa1 - oa5$ ) have not much effects to the trip pattern choices (as shown in Figure 3). However, it will affect the activities pattern greatly if the utilities of each activity comparable with the OD travel disutility. Furthermore, based on the numerical results, we can find the land use development scheme as shown in Table 6, is based on the travel pattern as shown in Table 5. That is, the land use development pattern are focused on the links 20-23, which cover the most travel pattern from home to work. This also demonstrates the importance of travel forecasting in the strategic urban planning.

## 6. Conclusions

This paper tentatively adopted a time-dependent activity-based approach and proposed a new bi-level programming model for investigating the land use allocation and transportation optimization problem. The upper level of the proposed model is used to determine the optimal residential and employment allocations and road link capacity enhancement. The lower-level model is to capture the choices of activity chain, departure time, path and activity duration of individuals simultaneously based on the time-dependent activity-based approach. Comparing existing modelling approach to investigate the land use allocation and transportation optimization problem, the proposed model presents a new activity-based approach. It has been shown that the activity scheduling equilibrium problem can be formulated as an equivalent variational inequality problem. A genetic-based method was adapted to solve the proposed bi-level programming model and to determine the optimal residential and employment allocations and road link capacity enhancement. Numerical examples are presented to demonstrate the application of the proposed model and solution algorithm.

In most of the existing land use and transportation optimization models, the trip-based approach was generally used to model the location and travel choice behaviors of commuters. In this paper, the time-dependent activity-based approach was adopted to model consistently the choices of activity chain, departure time, path and activity schedule duration of travelers within a typical day. As a result, the proposed bi-level optimization model can capture the interactions between land use and transportation development together with their impacts on activity-travel choice behaviors. This study provides a useful investigation for estimating the time-varying activity pattern over the time of day, and the proposed model can be used to investigate land use development and transport system at a short-term strategic planning level, and therefore could be considered a forward step from Wilson's quasi-dynamic model in his 1970 book (Wilson, 1970). The numerical results have shown that the interactive effects of the land use development and activity pattern variations of individuals.

To make our analysis tractable and intuitive, we have used two simple network examples to illustrate the insightful findings. It is definitely desirable to carry out case studies on realistic networks and further validation and calibration of the proposed optimization model with empirical data, this leaves for further studies. From the viewpoint of modeling, the proposed land use allocation and transportation optimization model can be extended to consider the uncertainty issues for short-term strategic planning. Besides the residential and employment development of land use, the development of public facilities (park, school, hospital, etc.) are also required for consideration in further study with extension of the proposed model. The influences of heterogeneous user classes should be investigated explicitly for the further development of the proposed model. The location and travel choice behaviors of individuals are also affected by members of the family together with family size and household income level. On the other hand, the algorithm development of the proposed model should be further investigated, and efficient solution algorithms could be developed for solving the proposed model in realistic large-scale networks. These issues can be explored in future studies.

### **Acknowledgements**

The work described in this paper was jointly supported by the National Natural Science Foundation of China (71361130016, 71422010, 71171013, and 71471013), National Basic Research Program of China (2012CB725401), grant from the Research Grants Council of the Hong Kong Special Administrative Region to the Hong Kong Polytechnic University (5181/13E), and the EU Marie Curie IIF (MOPED, 300674). The content is solely the responsibility of the authors and does not necessarily represent the views of the funding sources.

### **References:**

- Abraham, J., and Hunt J. 1997. "Specification and estimation of nested logit model of home, workplaces, and commuter mode choices by multiple individual households." *Journal of Transportation Research Record* 1606: 17-24.
- Arentze, T., and Timmermans, H. 2003. "Modeling learning and adaptation processes in activity-travel choice: a framework and numerical experiment." *Transportation* 30: 37-62.
- Bhat, C.R., Koppelman, F.S. 1999. "A retrospective and prospective survey of time-use research." *Transportation* 26 (2):119 - 139.
- Bhat, C.R. 2005. "A Multiple Discrete-Continuous Extreme Value model: formulation

- and application to discretionary time-use decisions.” *Transportation Research Part B* 39 (8):679 – 707.
- Bhat, C.R., Guo, J.Y. 2007.“A comprehensive analysis of built environment characteristics on household residential choice and auto ownership levels.” *Transportation Research Part B* 41 (5): 506 – 526.
- Bhat, C.R. 2008. “The Multiple Discrete-Continuous Extreme Value (MDCEV) model: role of utility function parameters, identification considerations, and model extensions.” *Transportation Research Part B* 42 (3): 274 – 303.
- Balling, R., Powell, B., Saito, M. 2004.“Generating future land use and transportation plans for high growth cities using a genetic algorithm.” *Computer-Aided Civil and Infrastructure Engineering* 19(3):213-222.
- Batty, M. 1976.*Urban Modelling: Algorithm, Calibrations, Predictions*, Cambridge University Press, Cambridge.
- Bok, M., Zondag, M., and Petersen, E. 2006.“Modelling land use in the generic urban model, Applied Method in Transport Planning: Proceedings of European Transport Conference.” *Land use and Transportation: Applied Methods in Transport Planning*.
- Boyce, D.E., Xiong, C. 2007.“Forecasting travel for very large cities: challenges and opportunities for China.” *Transportmetrica* 3:1 – 19.
- Boyce, D.E., Southworth F. 1979.“Quasi-dynamic urban location models with endogenously determined travel costs.” *Environment and planning A* 11: 575-584.
- Boyce, D.E., Mattsson, L. G. 1999.“Modeling residential location in relation to housing location and road tolls on congested urban highway networks.” *Transportation Research Part B* 33: 581-591.
- Cao, X., Mokhtarian, P.L., Handy, S.L. 2006.“Examining the impacts of residential self-selection on travel behavior: methodologies and empirical findings.” *Research Report UCD-ITS-RR-06-18*, Institute of Transportation Studies, University of California, Davis.
- Chang, J.S., and Mackett R.L. 2006.“A bi-level model of the relationship between transport and residential location.” *Transportation Research :Part B* 40: 123-146.
- Chen, H.K., 1999. “Dynamic travel choice models: a variational inequality approach.”*Springer-Verlag Berlin*.
- Chen, H.K., Hsueh, C.F. 1998.“A model and an algorithm for the dynamic user-optimal route choice problem.” *Transportation Research Part B* 32(3):219-234.
- Farooq, B. and Miller, E.J. 2012. “Towards integrated land use and transportation: a dynamic disequilibrium based micro simulation framework for built space markets, *Transportation Research A* 46(7):1030-1053.
- Feng, C.M., Hsieh, C.H. 2009.“Effect of resource allocation policies on urban transport diversity.” *Computer-Aided Civil and Infrastructure Engineering* 24(7) 525-533.
- Fu, X., Lam, W.H.K. 2014.“A network equilibrium approach for modelling activity-travel pattern scheduling problems in multi-modal transit networks with uncertainty.” *Transportation* 41(1): 37-55.
- Friesz, T.L., Bernstein, D., Smith, T.E., Tobin, R.L.,Wie, B.W. 1993.“A variational inequality formulation of the dynamic network user equilibrium problem.”

- Operations Research 41(1): 179-191.
- Ge, Y.E., Sun, B.R., Zhang, H.M., Szeto, W.Y. and Zhou, X. 2015. "A comparison of dynamic user optimal states with zero, fixed and variable tolerances," *Networks & Spatial Economics* 15(3): 583-598.
- Ge, Y.E., Zhou, X.Z. 2012. "An alternative definition of dynamic user optimum on signalized road networks." *Journal of Advanced Transportation* 46:236-253.
- Grant-Muller, S.M. and Xu, M. 2014. "The role of tradable credits schemes in road traffic congestion management." *Transport Reviews* 34(2): 128-149.
- Hao, J.Y., Hatzopoulou M. and Miller, E.J. 2010. "Integrating an activity-based travel demand model with dynamic traffic assignment and emissions models: an implementation in the Greater Toronto Area", *Journal of the Transportation Research Board* 2176: 1-13.
- Hoogendoorn, S.P., Bovy P.H.L. 2004. "Pedestrian route-choice and activity scheduling theory and models." *Transportation Research part B* 38:169-190.
- Huang, H.J., Li, Z.C., Lam, W.H.K., Wong, S.C. 2005. "A time-dependent activity and travel choice model with multiple parking options". *Transportation and Traffic Theory – Flow, Dynamics and Human Interaction*, Edited by Mahmassani, H.S., 2005, Elsevier, Oxford, 717-739.
- Huang, H.J., Lam, W.H.K. 2002. "Modeling and solving the dynamic user equilibrium route and departure time choice problem in network with queues." *Transportation Research Part B* 36(2): 253-273.
- Huang, H.J., Lam, W.H.K. 2005. "A stochastic model for combined activity/destination/route choice problems." *Annals of Operations Research* 135(1): 111-125.
- Hunt, J.D., Miller, E.J. and Kriger, D.S. 2005. "Current operational urban land-use transport modelling frameworks", *Transport Reviews* 25 (3): 329-376.
- Joh, C. H., Arentze, T. A., Timmermans, H. J. P. 2002. "Modeling individuals' activity-travel rescheduling heuristics: Theory and numerical experiments." *Transportation Research Record* 1807: 26-25.
- Jones, P.M., Dix, M.C., Clarke, M.I., Heggie, I.G. 1983. *Understanding travel behavior*, Gower, Aldershot.
- Kitamura, R. 1988. "An evaluation of activity-based travel analysis." *Transportation* 15: 9-34.
- Lam, W.H.K., Yin, Y. 2001. "An Activity-based Time Dependent Traffic Assignment Model," *Transportation Research Part B* 35(6): 549-574.
- Lam, W.H.K., Huang, H.J. 2002. "A combined activity/travel choice model for congested road networks with queues." *Transportation* 29(1): 5-29.
- Lam, W.H.K., Huang, H.J. 2003. "Combined activity/travel choice models: time-dependent and dynamic version." *Networks and Spatial Economics* 3:323-347.
- Lam, W.H.K., Li, Z.C., Huang, H.J., Wong, S.C. 2006. "Modeling time-dependent travel choice problems in road networks with multiple user classes and multiple parking facilities." *Transportation Research Part B* 40(5): 368-395.
- Lee, D.H., Wu, L., Meng, Q. 2006. "Equity based land-use and transportation problem." *Journal of Advanced Transportation* 40: 75 - 93.

- Li, Z.C., Lam, W.H.K., Wong, S.C., Sumalee, A. 2010. "An activity-based approach for scheduling multimodal transit services." *Transportation* 37(5): 751-774.
- Lin, J.J., Feng, C.M. 2003. "A bilevel programming model for the land use-network design problem." *The Annals of Regional Science* 37: 93-105.
- Liu, T.L., Huang, H.J., Yang, H., Zhang, X., 2009. "Continuum modeling of park-and-rideservices in a linear monocentric city with deterministic mode choice." *Transportation Research Part B* 43(6): 692-707.
- Lowry, I.S. (1964). *A model of metropolis*. Rand Corporation, Santa Monica.
- Meng, Q., Yang, H., Wong, S.C. 2000. "A combined land-use and transportation model for work trip." *Environment and Planning B: Planning and Design* 27: 93-103.
- Munroe, D.K., Muller, D. 2007. "Issues in spatially explicit statistical land use/cover change models: examples from western Honduras and the Central Highlands of Vietnam." *Land use Policy* 24(3): 521-530.
- Nagurney, A., Dong, J. 2002. "Urban location and transportation in the information age: a multiclass, multicriteria network equilibrium perspective." *Environment and Planning B* 29: 53 - 74.
- Ouyang, L.Q., Lam, W.H.K., Li, Z.C., Huang, D. 2011. "Network user equilibrium model for scheduling daily activity travel patterns in congested networks." *Journal of the Transportation Research Board* 2254: 131-139.
- Ouyang, L.Q., Lam, W.H.K. 2009. "An activity-based land use and transportation optimization." *Journal of the Eastern Asia Society for Transportation Studies*, 8.
- Peng, Z.R., Zhao, L., Yang, F. 2011. "Development of a prototype land use models for statewide transportation planning activities." Final report to the Systems Planning Office, Florida Department of Transportation.
- Pinjari, A.R., Bhat, C.R., Hensher, D.A. 2009. "Residential self-selection effects in an activity time-use behavior model." *Transportation Research Part B* 43: 729-748.
- Ran, B., Boyce, D.E. 1996. "Modelling dynamic transportation networks: An intelligent transportation system oriented approach (2<sup>nd</sup> revised edition)", Springer, New York.
- Ruiz, T., Roorda, M.J. 2011. "Assessing planning decisions by activity type during the scheduling process." *Transportmetrica* 7(6):417-442.
- Sheffi, Y. 1985. *Urban transportation networks: equilibrium Analysis with mathematical programming methods*. Prentice-Hall, Englewood Cliffs, N.J.
- Szeto, W.Y., Jaber, X., O'Mahony, M. 2010. "Time-dependent discrete network design frameworks considering land use." *Computer-Aided Civil and Infrastructure Engineering* 25(6): 411-426.
- Recker, W.W. 2001. "A bridge between travel demand modeling and activity-based travel analysis." *Transportation Research Part B* 35: 481-506.
- Recker, W., Duan, J., Wang, H. 2008. "Development of an estimation procedure for an activity based travel demand model." *Computer-Aided Civil and Infrastructure Engineering* 23(7): 483-501.
- Stewart, K.J., Ge, Y.E., 2014. "Optimising time-varying network flows by low-revenue tolling under dynamic user equilibrium." *European Journal of Transport and Infrastructure Research* 14(1):30-45.

- Timmermans, H., The saga of integrated land use-transport modelling: how many more dreams before we wake up? Conference Keynote Paper on 10<sup>th</sup> International Conference on Travel Behaviour Research, Lucerne, 10-15. August 2003.
- Timmermans, H.J.P. 2005. Progress in activity-based analysis. Elsevier, Amsterdam, Netherlands.
- Waddell, P. 2001. Towards a behavioral integration of land use and transportation modeling. In: Hensher, D. (Ed.), Travel Behavior Research: The Leading Edge. Pergamon, New York, 65 - 95.
- Waddell, P. 2002. "UrbanSim-Modelling urban development for land use, transportation, and environmental planning." Journal of the American Planning Association 68(3): 297-314.
- Wang, D., Li, J. 2011. "A two-level multiple discrete-continuous model of time allocation to virtual and physical activities." Transportmetrica 7(6): 395-416.
- Wegener, M., Overview of land-use transport models, Chapter 9 in David A. Hensher and Kenneth Button (Eds.): Transport Geography and Spatial Systems. Handbook 5 of the Handbook in Transport. Pergamon/Elsevier Science, Kidlington, UK, 2004, 127-146.
- Williams, H., Coelho, J.D. 1978. "On the design of land use plans through location surplus maximization." Papers of the Regional Science Association 40: 71-85.
- Wilson, A. 1970. Entropy in Urban and Regional Modelling, London: Pion.
- Wong, C.K., Wong, S.C., Tong, C.O. 1998. "A new methodology for calibrating the Lowry model." Journal of Urban Planning and Development 124: 72 - 91.
- Xu, M., Gao, Z.Y., 2009. "Multi-class multi-modal network equilibrium with regular choice behaviors: a general fixed point approach," (William H.K. Lam, S.C. Wong, Hong K. Lo, Eds) Transportation and Traffic Theory 2009: Golden Jubilee (ISTTT18), 301-326.
- Xu, M., Grant-Muller, S., Huang, H.J., Gao, Z.Y. 2015 "Transport management measures in the post-Olympic Games period: supporting sustainable urban mobility for Beijing?", International Journal of Sustainable Development & World Ecology 22(1): 50-63.
- Xu, M., Grant-Muller, S., Gao, Z.Y. 2015 "Evolution and assessment of economic regulatory policies for expressway infrastructure in China." Transport Policy 41:50-63.
- Yang, H., Bell, M.G.H. 1998. "Models and algorithms for road network design: a review and some new developments." Transport Reviews 18: 257 - 278.
- Yang, H., Meng, Q. 1998. "An integrated network equilibrium model of urban location and travel choices." Journal of Regional Science 38: 575 - 598.
- Yang, H., Bell, M.G.H., Meng, Q. 2000. "Modeling the capacity and level of service of urban transportation networks." Transportation Research Part B 34: 255 - 275.
- Yang, J. 2008. Comparing and analyzing intelligent optimization algorithms for urban transportation continuous network design problem. M.Phil Thesis, School of Traffic and Transportation, Beijing Jiaotong University.
- Yim, K.K.W., Wong, S.C., Chen, A., Wong, C.K., Lam, W.H.K. 2011. "A reliability-based land use and transportation optimization model." Transportation Research



Part C 19: 351-362.

Ying, J.Q. 2007. "Continuous optimization method for integrated land use/transportation models." *Journal of Transportation Systems Engineering and Information Technology* 7(3): 64-72.

Zhang, H. M. and Ge, Y.E.2004. "Modeling variable demand equilibrium under second-best road pricing." *Transportation Research Part B* 38: 733-749.

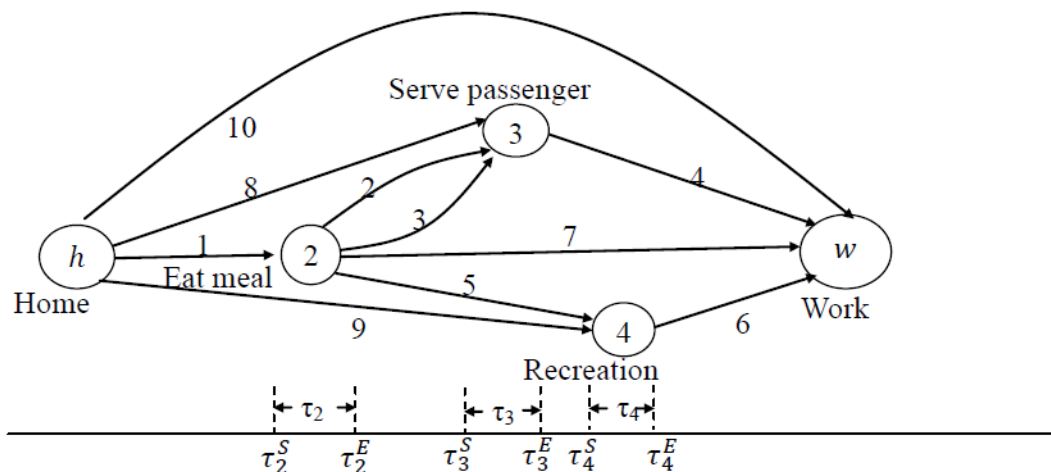

Figure 1. Home-based activity chains and their paths

1. Activity set  $I = \{h, 2, 3, 4, w\}$

Activity (location, node)  $h$ : Home;

Activity (location, node) 2: Eat meal;

Activity (location, node) 3: Serve passenger;

Activity (location, node) 4: Recreation;

Activity (location, node)  $w$ : Work.

2. Activity chain set  $P_{hw} = \{p1, p2, p3, p4, p5, p6, p7\}$



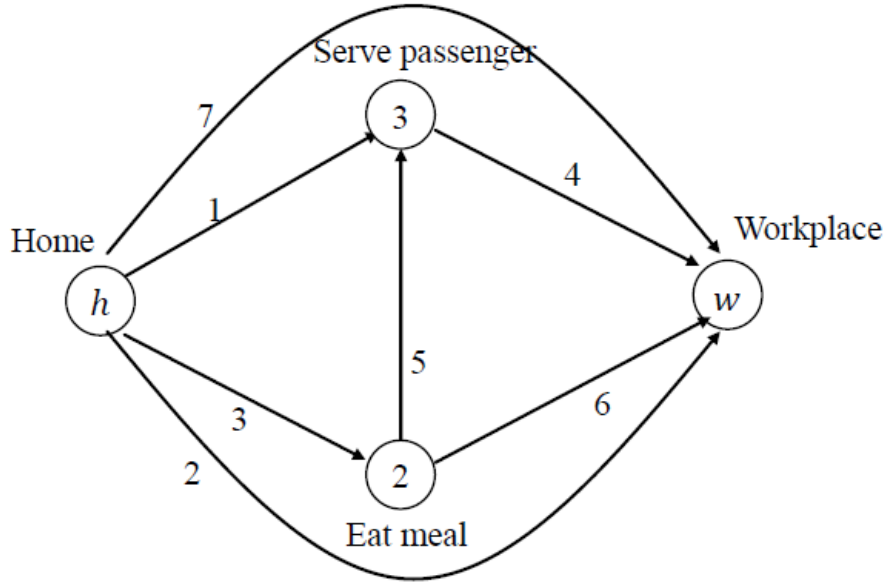

Figure2. Network in example 1

1. Activity set  $I = \{h, 2, 3, w\}$

Activity (location, node)  $h$ : Home;

Activity (location, node) 2: Eat meal;

Activity (location, node) 3: Serve passenger;

Activity (location, node)  $w$ : Work.

2. Activity chain set  $P_{hw} = \{p1, p2, p3, p4\}$

$p1 = \{h, 2, 3, w\}$  (“home – eat meal – serve passenger – work”);

$p2 = \{h, 2, w\}$  (“home – eat meal – work”);

$p3 = \{h, 3, w\}$  (“home – serve passenger – work”);

$p4 = \{h, w\}$  (“home – work”).

3. Path set between activity  $i$  and activity  $j$  and path set of activity chain

$$R_{h,2}^{p1} = \{3\}; R_{2,3}^{p1} = \{5\}; R_{3,w}^{p1} = \{4\}; R_{h,w}^{p1} = \{R_{h,2}^{p1} \times R_{2,3}^{p1} \times R_{3,w}^{p1}\} = \{r1: 3 - 5 - 4\}.$$

$$R_{h,2}^{p2} = \{3\}; R_{2,w}^{p2} = \{6\}; R_{h,w}^{p2} = \{R_{h,2}^{p2} \times R_{2,w}^{p2}\} = \{r2: 3 - 6\}.$$

$$R_{h,3}^{p3} = \{1\}; R_{3,w}^{p3} = \{4\}; R_{h,w}^{p3} = \{R_{h,3}^{p3} \times R_{3,w}^{p3}\} = \{r3: 1 - 4\}.$$

$$R_{h,w}^{p4} = \{r4: 2; r4: 7\}.$$

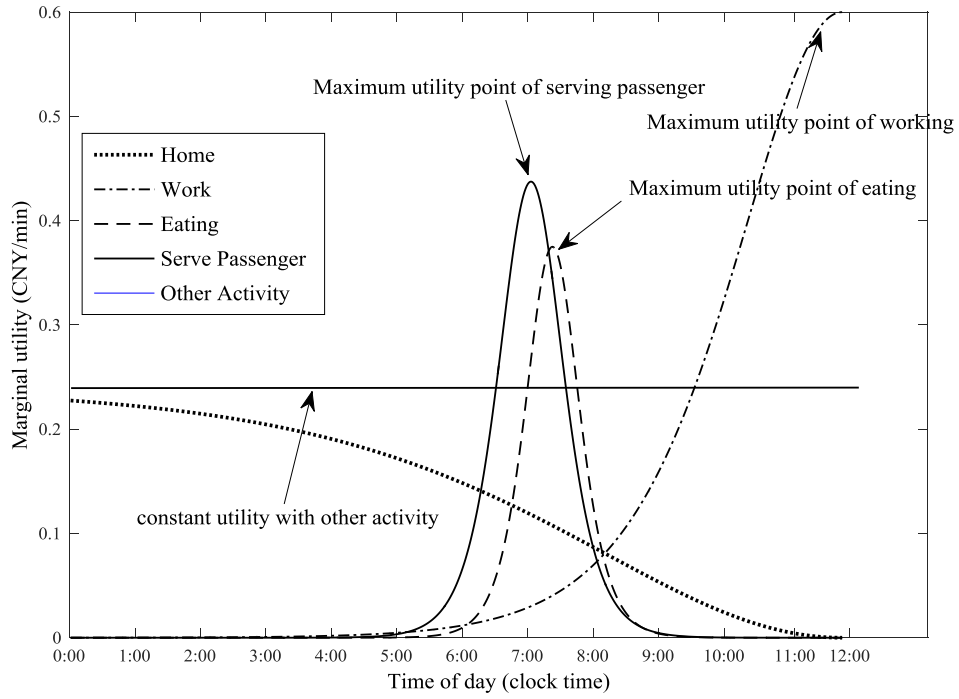

Figure 3. The marginal utility curves for different activities

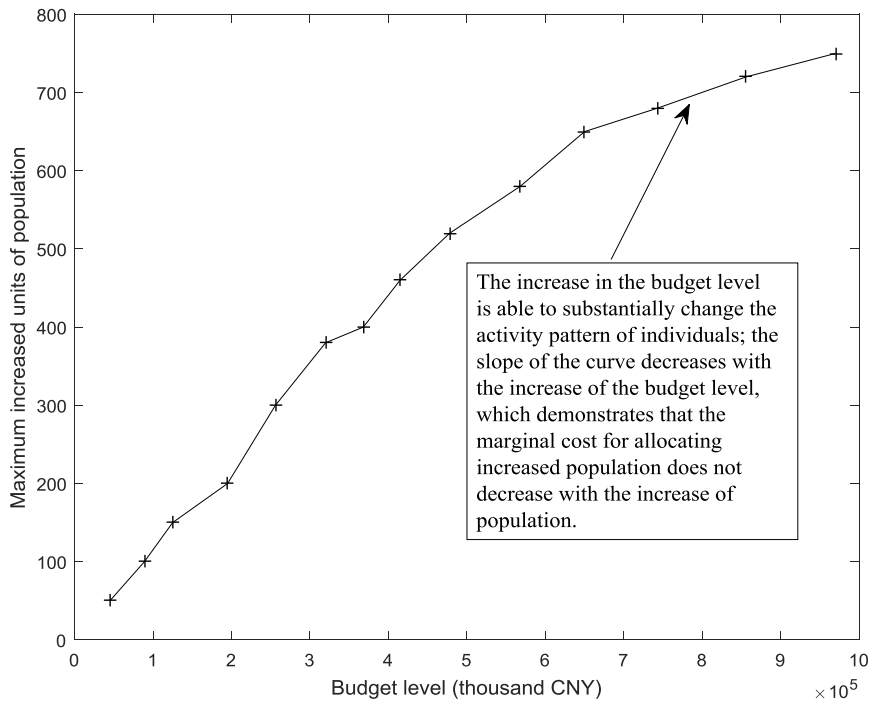

Figure 4. The maximum increased units of population versus different values of budget level (unit: Thousand CNY)

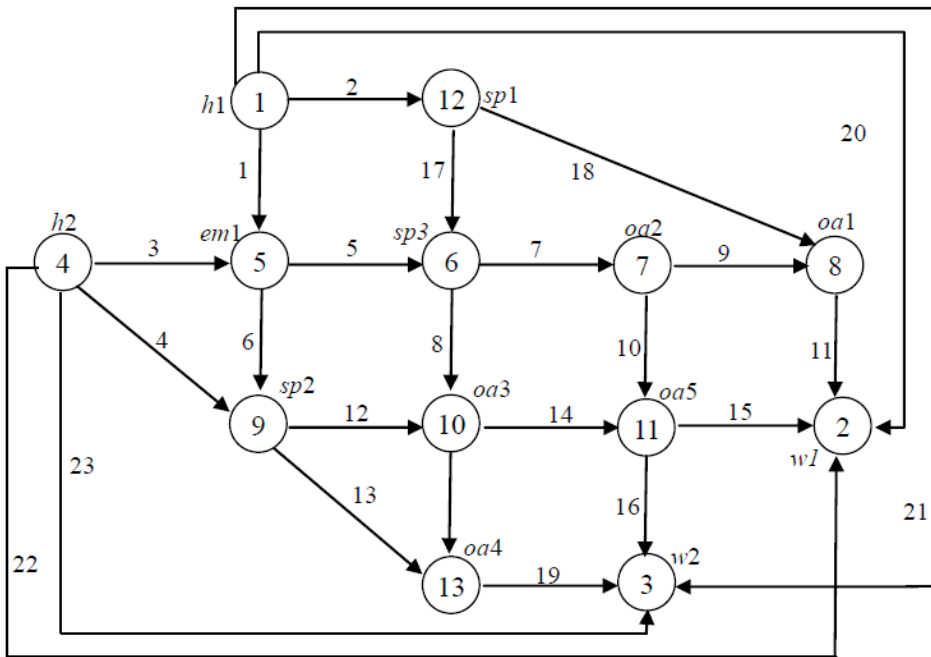

Figure 5. A slightly larger network in example 2

Table 1 Link characteristics of the example network

Link No.	Length of link (km)	Free-flow time(min)	Capacity of link (pcu/h)
1	7	9	2000
2	15	18	2000
3	6	7	2000
4	7	8	2000
5	3	2	2000
6	5	4	2000
7	10	12	2000

Table 2 Input parameters for the marginal utility functions of four activities.

Parameter	Home	Eat meal	Serve passenger	Work
$\rho$	-0.006	0.060	0.050	0.015
$\lambda$	1.0	1.0	1.0	1.0
$\xi$	720	450	430	720
$U^{max}$	160	25	35	160
$U^0$	0.24	0.00	0.00	0.00

Table 3 The optimal land use and transportation development pattern in example 1

$Q$ (units of population)	2400
$\bar{Q}$ (units of population)	2000
$\Delta Q$ (units of population)	400
$B$ (thousand CNY)	368000
Land use expansion (thousand CNY)	320000
Resident $h$ (units of residents)	400
Employment $w$ (units of employment)	400
Link capacity expansion (thousand CNY)	48000
Link 1 (pcu)	45.61
Link 2(pcu)	90.32
Link 3(pcu)	80.12
Link 4(pcu)	66.25
Link 5(pcu)	0
Link 6(pcu)	47.3
Link 7(pcu)	69.59
Travel demand for different chains	
$p1$ (“home – eat meal – serve passenger – work”) (pcu)	22
$p2$ (“home – eat meal– work”) (pcu)	57
$p3$ (“home – serve passenger – work”) (pcu)	101
$p4$ (“home – work”) (pcu)	220
Average duration for different activities (hour)	
Home (hour)	7.5
Eat meal (hour)	0.25
Serve passenger(hour)	0.45
Work(hour)	3.8



Table 4. Link characteristics of the example network in Figure 5

Link nos	$T_a^0$ (min)	$C_a$ (pcu/min)	$T_a^1$	$T_a^2$
1	7	7	0.0125	1
2	9	9	0.01	1
3	9	9	0.01	1
4	12	12	0.005	1
5	3	3	0.0075	1
6	9	9	0.0075	1
7	5	5	0.0125	1
8	13	13	0.005	1
9	5	5	0.0125	1
10	9	9	0.0125	1
11	9	9	0.0125	1
12	10	10	0.005	1
13	9	9	0.005	1
14	6	6	0.0025	1
15	9	9	0.005	1
16	8	8	0.01	1
17	7	7	0.0125	1
18	14	14	0.01	1
19	11	11	0.01	1
20	35	35	0.01	1
21	40	40	0.01	1
22	38	38	0.01	1
23	33	33	0.01	1

Table 5. The trip pattern in Figure 5

Travel demand for different chains (pcu)	Trip chain patterns (link nos)	Trip chain Flow (pcu)	Trip chain cost (min)
1-2	1. $h1 - w1$ (20)	90.88	47.05
$h1 - w1$	2. $h1 - sp1 - oa1 - w1$ (2-18-11)		
$Q_{12} = 100$	3. $h1 - em1 - sp3 - oa2 - oa1 - w1$ (1-5-7-9-11)	9.12	47.05
	4. $h1 - em1 - sp3 - oa2 - oa5 - w1$ (1-5-7-10-15)	0	49.44
	5. $h1 - em1 - sp3 - oa3 - oa5 - w1$ (1-5-8-14-15)	0	53.13
	6. $h1 - em1 - sp2 - oa3 - oa5 - w1$ (1-6-12-14-15)	0	54.52
	7. $h1 - sp1 - sp3 - oa2 - oa1 - w1$ (2-17-7-9-11)	0	58.59
	8. $h1 - sp1 - sp3 - oa2 - oa5 - w1$ (2-17-7-10-15)	0	53.35
	9. $h1 - sp1 - sp3 - oa3 - oa5 - w1$ (2-17-8-14-15)	0	56.67
		0	57.98
1-3	10. $h1 - w2$ (21)	180	61.11
$h1 - w2$	11. $h1 - em1 - sp2 - oa4 - w2$ (1- 6-13-19)	4.48	61.11
$Q_{13} = 200$	12. $h1 - em1 - sp3 - oa2 - oa5 -$ $w2$ (1-5-7-10-16)	15.52	61.11
	13. $h1 - em1 - sp2 - oa3 - oa5 -$ $w2$ (1-5-8-14-16)	0	62.35
	14. $h1 - sp1 - sp3 - oa2 - oa1 -$ $w2$ (1-6-12-14-16)	0	65.99
	15. $h1 - sp1 - sp3 - oa2 - oa5 - w2$ (2-17-7-10-16)	0	61.78
	16. $h1 - sp1 - sp3 - oa3 - oa5 - w2$ (2-17-8-14-16)	0	66.88
4-2	17. $h2 - w1$ (22)	140	52.66
$h2 - w1$	18. $h2 - sp2 - oa3 - oa5 - w1$ (4- 12-14-15)	7.97	52.66
$Q_{42} = 150$	19. $h2 - em1 - sp3 - oa2 - oa1 -$ $w1$ (3-5-7-9-11)	2.03	52.66
	20. $h2 - em1 - sp3 - oa2 - oa5 -$ $w1$ (3-5-7-10-15)	0	55.54
	21. $h2 - em1 - sp3 - oa3 - oa5 -$ $w1$ (3-5-8-14-15)	0	57.68
	22. $h2 - em1 - sp2 - oa3 - oa5 -$ $w1$ (3-6-12-14-15)	0	62.34
4-3	23. $h2 - w2$ (23)	45	43.69
$h2 - w2$	24. $h2 - sp2 - oa4 - w2$ (4-13-19)		
$Q_{43} = 50$	25. $h2 - sp2 - oa3 - oa5 - w2$ (4- 12-14-16)	5	43.69
	26. $h2 - em1 - sp2 - oa4 - w2$ (3- 6-13-19)	0	46.32
		0	47.34
	27. $h2 - em1 - sp3 - oa2 - oa5 -$ $w2$ (3-5-7-10-16)	0	50.45
	28. $h2 - em1 - sp3 - oa3 - oa5 -$ $w2$ (3-5-8-14-16)	0	52.17
	29. $h2 - em1 - sp2 - oa3 - oa5 -$ $w2$ (3-6-12-14-16)	0	57.65

Table 6 The optimal land use development pattern in Figure 5

$Q_1 = 3600; Q_4 = 2400$ (units of population)
$\bar{Q}_1 = 3300; \bar{Q}_4 = 2200$ (units of population)
$\Delta Q_1 = 300; \Delta Q_4 = 200$ (units of population)
$B = 1.32 * 10^5$ (thousand CNY)
Land use expansion= $1.3 * 10^5$ (thousand CNY)
Resident $h_1=300; h_4=200$ (units of residents)
Employment $w_2=250; w_3=250$ (units of employment)
Link capacity expansion=20000 (thousand CNY)
Link 20=33.4; Link 21=40.2; Link 22=35.9; Link 23=31.5. (pcu)