

An Adaptive Neuro-Fuzzy Inference System (ANFIS) Approach for Measuring Country Sustainability Performance

Yongtao Tan^{a*}, Chenyang Shuai^{a,b}, Liudan Jiao^{a,b} and Liyin Shen^b

^a Department of Building & Real Estate, The Hong Kong Polytechnic University, Hung Hom, Kowloon, Hong Kong.

^b School of Construction Management & Real Estate, Chongqing University, Chongqing 400045, China.

*Corresponding author. Tel: + 852 2766 5828 Fax: +852 2764 5131.

E-mail addresses: bstan@polyu.edu.hk (Yongtao Tan), 1391843874@qq.com (Chenyang Shuai), 396732441@qq.com (Liudan Jiao), shenliyin@cqu.edu.cn (Liyin Shen)

1 An Adaptive Neuro-Fuzzy Inference System (ANFIS) 2 Approach for Measuring Country Sustainability Performance

3 **Abstract**

4 With the increasing demand for sustainable development, many international
5 institutions and governments are seeking a balance between the environment, society
6 and economy. With the aim of understanding and monitoring sustainability
7 performance, various sustainability assessment methods have been developed. Fuzzy
8 logic theory has been widely used for sustainability assessment. Good as these
9 approaches are, there are criticisms that most studies use pre-defined simple linear
10 membership functions (triangular or trapezoidal) and fuzzy rules, which are largely
11 derived from experts' knowledge. However, sustainability is a very complex, multi-
12 criteria issue, which contains various complex non-linear relationships. Moreover, it
13 is time-consuming to find out the optimal membership functions and rules based on
14 the expert knowledge. Therefore, it becomes necessary to explore a new approach for
15 induction of membership functions and fuzzy rules. This paper introduces the
16 adaptive neuro-fuzzy inference system (ANFIS) approach for country level

1 sustainability assessment. The membership functions and fuzzy rules are generated
2 from 128 training samples. The assessment results are close to the SAFE,
3 *Sustainability Assessment by Fuzzy Evaluation*, model. Furthermore, three different
4 types of non-linear membership functions, including Gaussian, bell-shaped and
5 sigmoidal, are tested. The Gaussian membership function is the best one for country
6 sustainability assessment. This study explores sustainability assessment, and results
7 show that, by using appropriate training data, the ANFIS method is effective to
8 measure the countries' sustainability performance. Using ANFIS, assessment
9 accuracy can be further improved through appropriate selection of training samples
10 using alternative data from UN-Habitat, or World Bank, or even new data sets.

11 Keywords: Sustainability assessment; adaptive neuro-fuzzy inference system
12 (ANFIS); artificial neural-network; fuzzy set theory; decision-making

13 **1 Introduction**

14 Over the past few decades, the world has experienced substantial economic and
15 social development. The statistics show that the GDP has increased from 1423.6
16 billion US dollars in 1961 to 77,696 billion dollars in 2014, or approximately 54.5

1 times with an annual average growth rate of 8.1%. Over the same time period, the
2 total population has also increased from 3.076 billion (1961) to 7.259 billion (2014),
3 accounting for nearly 2.4 times. However, the economic and social development has
4 also caused a number of environmental problems, such as global warming, habitat
5 destruction, desertification and source depletion (Bond and Morrison-Saunders, 2011;
6 Chen and Lu, 2017; Lu et al., 2016; Retief et al., 2016; Shen et al., 2012; Shuai et al.,
7 2017; Wende et al., 2012). Therefore, the recognition of these problems caused by
8 rapid development has led to the promotion of sustainable development (Zhou et al.,
9 2015a).

10 Sustainable development was defined as “...*meeting the needs of the present*
11 *without compromising the ability of future generations to meet their own needs*” by
12 a key pioneer, Brundtland (1987). Since then, sustainable development has become a
13 global issue. Since the turn of the century, many intergovernmental programs and
14 private initiatives have been implemented to promote global sustainable development,
15 such as the New Urban Agenda by UN-Habitat (2016), Sustainable Development
16 Goals by United Nations (2016) , and Istanbul Declaration by North Atlantic Treaty

1 Organization (NATO) (2004), the HK2030 Study by Hong Kong Planning
2 Department (2007), City plan 2010 by Melbourne City Council (2001), and Plan
3 Verde by Government of Mexico City (2007). With the implementation of various
4 sustainable development programs, it is considered that the recognition of sustainable
5 development performance is important in the pursuit of effective sustainable
6 development, since it has been invested with a great many resources (Tan et al., 2016).

7

8 In line with the sustainable developments, many research efforts have been
9 focused on sustainability assessment (Jiao et al., 2016; Lu et al., 2015; Peng, 2015;
10 Shen et al., 2016, 2017; Shen et al., 2015; Tan et al., 2015; Tan et al., 2014; Tan et al.,
11 2011; Zhou et al., 2015b). Among them, fuzzy-set theory has also been applied for
12 sustainability performance assessment. For example, Houshyar et al. (2014) used
13 fuzzy-set theory to measure the sustainability performance of agriculture development.
14 Cavallaro (2015) proposed an application of Takagi-Sugeno fuzzy inference
15 modelling to build a synthetic index for monitoring the sustainability performance of
16 energy production. Zhao and Li (2016) established the hybrid stochastic AHP and

1 fuzzy TOPSIS model to evaluate the sustainability performance of smart grids.
2 However, in most of these existing studies, pre-defined linear membership functions
3 (triangular or trapezoidal) and fuzzy rules are commonly applied, which are based on
4 experts' knowledge. These have led to criticism that the sustainability is a very
5 complex, multi-criteria and dynamic issue, which contains various complicated non-
6 linear relationships between variables such as measures of the economy, environment
7 and resources etc. (Hjorth and Bagheri, 2006). Furthermore, Singh et al. (2012)
8 argued that it is time-consuming to find out the correct membership functions and
9 rules that result in a reliable solution, because it requires time to process the expert
10 knowledge.

11 Therefore, there is a need to explore a new approach for induction of fuzzy
12 membership function and fuzzy rules. This paper aims to: (1) review the existing
13 studies on country sustainability assessment; (2) introduce ANFIS, a new approach;
14 (3) apply the ANFIS approach to re-assess country sustainability based on the work
15 by Phillis et al. (2011); and (4) test different membership functions. The main
16 contribution of this paper is to introduce a new approach, ANFIS, for country

1 sustainability assessment, which makes the assessment process independent of expert
2 knowledge and close to human reasoning. Furthermore, a framework for optimal
3 membership function selection was proposed. The proposed ANFIS approach has
4 been shown here to be feasible and effective for country sustainability assessment,
5 and can be further improved by integrating new training data.

6 **2 Literature Review**

7 Sustainability assessment is defined as “*...a tool that can help decision-makers*
8 *and policy-makers decide which actions they should or should not take in an*
9 *attempt to make society more sustainable*” (Devuyst et al., 2001). Currently, various
10 methods, techniques and tools have been developed for country sustainability
11 assessment. These methods can be summarized into 5 categories including: (1)
12 Ecological footprint (Strezov et al., 2016); (2) Data envelopment analysis (Iribarren et
13 al., 2016; Santana et al., 2014); (3) Comprehensive evaluation (Coteur et al., 2016;
14 Dor and Kissinger, 2017; Veldhuizen et al., 2015); (4) System dynamics (Karami et
15 al., 2017; Onat et al., 2016); and (5) Fuzzy-set theory (Phillis and
16 Andriantiatsaholiniaina, 2001; Phillis et al., 2011). These methods are either

1 efficiency-oriented or output-oriented. For example, DEA is a typical efficiency-
2 oriented assessment method (Yu and Wen, 2010). This efficiency-oriented approach
3 has been widely applied in ecological footprint studies (Yan et al., 2002). However,
4 Li and Li (2009) pointed out that the results obtained from the DEA method only
5 present the relevant efficiency of individual indicators. Taking the environmental
6 dimension in the sustainable development as an example, the energy efficiency for
7 reducing carbon emission in USA is quite high, which indicates good environmental
8 performance. However, USA is the second largest carbon emitter in the world when
9 considering the total carbon emission (Guan et al., 2008). The output-orientated
10 principle has been widely used for comprehensive analysis (Yigitcanlar et al., 2015).
11 Nevertheless, Shen et al. (2015) emphasized that the output-orientated principle only
12 focuses on outcomes rather than the process, which presents difficulties for city
13 decision-makers when selecting a suitable development strategy.

14 Sustainability assessment is a complex problem, which considers multi-criteria
15 simultaneously (Ness et al., 2007). Cornelissen et al. (2001) commented that
16 uncertainty related to sustainable development must be considered in sustainability

1 assessment. Furthermore, some soft (qualitative) indicators such as corruption and
2 poverty are also significant to reflect a sustainable performance. These soft indicators
3 cannot be quantified by selecting a crisp number. Instead, discrete variables, using
4 linguistic terms, such as “Good”, “Normal”, “Bad”, can be used for representing these
5 indicators (Phillis and Andriantiatsaholiniaina, 2001). Mendoza and Prabhu (2003)
6 also stressed that sustainability assessment requires both qualitative and quantitative
7 criteria rather than only using simple qualitative criteria. These features make fuzzy-
8 set theory more appropriate for sustainability assessment than other methods. This
9 point has also been echoed by other researchers. For example, Ratnayake (2014)
10 suggested that fuzzy-set theory enables connecting and handling both qualitative and
11 quantitative criteria. Zhou et al. (2015c) pointed out that fuzzy-set theory can deal
12 with systematic uncertainties. Andriantiatsaholiniaina et al. (2004) asserted that fuzzy
13 logic is a systematic tool for sustainability assessment, which can deal with those
14 imperfect data. Phillis and Andriantiatsaholiniaina (2001) concluded that fuzzy logic
15 is a natural technical method for sustainability assessment because fuzzy logic can
16 emulate the behaviour of skilled humans and handle vague situations.

1 Fuzzy-set theory has therefore been widely applied in country sustainability
2 assessment by many researchers (Grigoroudis et al., 2014; Jayaraman et al., 2015;
3 Kouikoglou and Phillis, 2011; Kouloumpis et al., 2008; Liu et al., 2014; Phillis et al.,
4 2011; Phillis and Kouikoglou, 2009). However, ***pre-defined linear membership***
5 ***functions*** (triangular or trapezoidal) and fuzzy rules that basically depend on expert
6 knowledge are commonly used in existing studies, which cannot reflect the non-linear
7 relationships between variables (Hjorth and Bagheri (2006)and it is time-consuming
8 to define the correct membership functions and rules (Singh et al. (2012).

9 In searching for a better possible solution, the use of an artificial neural networks
10 (ANN) is considered as an intelligence technique which specifies the relationship
11 between input and output from training samples to determine distribution of
12 membership functions (Naderloo et al., 2012). However, it is not easy to determine
13 the proper size and optimal structure of the network, which is a main disadvantage of
14 neural network (Singh et al., 2012). Combining the ANN and fuzzy-set theory can
15 overcome the disadvantages of both techniques. An adaptive neural fuzzy inference
16 system (ANFIS) method for fuzzy membership function and fuzzy rules induction

1 was introduced by Jang (1993). The ANFIS has combined the advantages of fuzzy
2 systems for dealing with explicit knowledge, which can be explained and understood
3 (such as fuzzy inference system), with neural networks for dealing with implicit
4 knowledge, which can be acquired by learning (such as membership function) (Singh
5 et al., 2012).

6 Since then, the ANFIS method has been widely applied in different research
7 areas, such as knowledge discovery (Inyang and Akinyokun, 2014), prediction
8 (Abdulshahed et al., 2015; Hegde and Raju, 2015) and decision-making (Hashemi et
9 al., 2013; Özkan and Inal, 2014). Further, and even more relevant to this paper's study,
10 the ANFIS method has also been used for assessment. For example, Mohandes et al.
11 (2011) used the ANFIS method to estimate the wind speed profile, and concluded that
12 it provided high accuracy and reliability for assessing the wind speed. Sangaiah et al.
13 (2015) innovatively integrated the ANFIS approach with a Taguchi-genetic learning
14 algorithm to evaluate outcomes of global software development. This study is the first
15 attempt to apply the ANFIS approach to country sustainability assessment.

16 **3 The principle of ANFIS**

1 Adaptive Neural Fuzzy Inference System (ANFIS) was first proposed by Jang
2 (1993). ANFIS constructs a fuzzy inference system (FIS) whose membership function
3 parameters are derived from training examples. Assume a FIS under consideration has
4 two inputs x and y with two associated membership functions (MFs), and one output
5 (z). For a typical first-order Takagi-Sugeno fuzzy model (Sugeno, 1985), a common
6 rule set, with two fuzzy if-then rules, is presented as follows:

7 Rule 1: if x is A_1 and y is B_1 , then $f_1 = a_1x + b_1y + c_1$,

8 Rule 2: if x is A_2 and y is B_2 , then $f_2 = a_2x + b_2y + c_2$,

9 where A_1, A_2, B_1 and B_2 are the linguistic labels of the inputs x and y respectively, and
10 $(a_i, b_i, c_i)(i= 1, 2)$ are the parameters (Jang, 1993). Figures 1(a) and 1(b) illustrate the
11 reasoning mechanism and the corresponding ANFIS architecture, respectively (Jang,
12 1993).

13 *<Insert Figure 1(a) Here>*

14 *<Insert Figure 1(b) Here>*

15 As shown in Figure 1(b), ANFIS is a multi-layer network. The operation of ANFIS
16 model from layer 1 to layer 5 is briefly presented below (Jang, 1993).

1 Layer 1: All the nodes in this layer are adaptive nodes, which indicate that the
 2 shape of membership function can be modified through training. Taking
 3 Gaussian MFs as an example, the generalized MFs are defined as follows:

$$4 \quad O_i^1 = \mu_{A_i}(x) = e^{-\frac{(x - c_i)^2}{2\sigma_i^2}}$$

5 where x is crisp input to node i , and A_i is the linguistic label, such as low, medium
 6 and high. O_i^1 is the membership grade of fuzzy-set A_i , which can be trapezoidal,
 7 Gaussian, bell-shaped and sigmoid functions or others. The variables (σ_i, c_i) are
 8 the parameters of the MF governing the Gaussian function. Furthermore, other
 9 two types of non-linear membership functions including bell-shaped and
 10 sigmoidal membership functions will be tested in the discussion section.

$$11 \quad \mu_{A_i}(x) = \frac{1}{1 + \left| \frac{x - c_i}{a_i} \right|^{2b_i}} \text{ (Bell-shaped MF)}$$

$$12 \quad \mu_{A_i}(x) = \frac{1}{1 + e^{-a_i(x - c_i)}} \text{ (Sigmoidal MF)}$$

13 Where (a_i, b_i, c_i) and (a_i, c_i) are the parameters governing the bell-shaped MF and
 14 sigmoidal MF, respectively.

1 Layer 2: The nodes in this layer are circle nodes labeled Π , indicating that they
 2 perform as a simple multiplier. Each node output represents the firing strength
 3 of each rule.

$$4 \quad O_i^2 = w_i = \mu_{A_i}(x) \times \mu_{B_i}(x), \quad i = 1,2$$

5 Layer 3: The nodes in this layer are also circle nodes labeled N . The i th node is
 6 the ratio of the i th rule's firing strength to the sum of all rules' firing strengths.

7 The outputs of this layer can be given by

$$8 \quad O_i^3 = \bar{w}_i = \frac{w_i}{w_1 + w_2}, \quad i = 1,2$$

9 Layer 4: Each node i in this layer is adaptive. Parameters in this layer are
 10 considered as consequent parameters. The outputs of this layer can be
 11 represented as

$$12 \quad O_i^4 = \bar{w}_i f_i = \bar{w}_i (p_i x + q_i y + r_i), \quad i = 1,2$$

13 Layer 5: The node in the last layer computes the overall output as the summation
 14 of all incoming signals. The overall output is given as

$$15 \quad O_i^5 = z = \sum_{i=1}^2 \bar{w}_i f_i = \frac{w_1 \times (p_1 x + q_1 y + r_1) + w_2 (p_2 x + q_2 y + r_2)}{w_1 + w_2}$$

16 In the ANFIS architecture, the major task of the training process is to make the
 17 ANFIS output fit with the training data by optimizing the fuzzy rules and parameters

1 of membership functions. The hybrid-learning algorithm incorporating gradient
2 method and the least-squares are used in ANFIS to estimate the initial parameters and
3 quantify the mathematical relationship between input and output. The details of the
4 gradient method and the least-squares estimate method of ANFIS can be found in the
5 study of Jang (1993).

6 **4 Sustainability assessment by using ANFIS approach**

7 Fuzzy set theory has been used for sustainability assessment by Phillis and
8 Andriantiatsaholiniaina (2001). A SAFE (Sustainability Assessment by Fuzzy
9 Evaluation) model was developed, which has a hierarchical structure. The overall
10 sustainability is assessed by two major components, ecological sustainability and
11 human sustainability. Each major component is comprised with secondary
12 components, and each secondary component has three categories, including pressure,
13 status, and response. In SAFE model, each category is assessed by using relevant
14 time-series of basic indicators. The values of these basic indicators are from
15 international agreements and norms, laws and regulations, as well as expert opinion.
16 The basic indicators are normalized within [0,1] by linear interpolation between

1 sustainable and unsustainable indicator values. Furthermore, the exponential
2 smoothing method is employed for aggregating the time-series data, and an
3 imputation procedure is used for handling the missing data. Additionally, the SAFE
4 model uses fuzzy logic to combine the basic indicators to form composite indicators,
5 composite indicators to form major components, and, finally computes the overall
6 sustainability of a country. ANFIS is basically a disaggregation approach in decision-
7 making problems, while the SAFE approach is mainly an aggregation approach.

8 To demonstrate the application of the ANFIS approach for sustainability
9 assessment, training samples are required. Therefore, with the permission of Dr.
10 Yannis A Phillis, the data used in the SAFE model were collected as the training data.
11 The SAFE model uses linear triangular and trapezoidal membership functions, and
12 pre-defines the membership functions and fuzzy rules. With the ANFIS approach, a
13 Gaussian membership function will be used, because this distribution fits a lot of real-
14 world problems (Moghaddamnia et al., 2009). The membership functions and fuzzy
15 rules are derived from the existing samples. There are four steps of country
16 sustainability assessment by using the ANFIS, shown as follows.

1 Step1. Hierarchical structure of ANFIS model

2 This study is based on the SAFE model developed by Phillis et al. (2011). In
3 their study, a four-level hierarchical structure was developed to evaluate the
4 sustainability of countries. The overall sustainability performance is the first level.
5 There are two primary components in the second level to evaluate overall
6 sustainability performance (OSUS), including human sustainability (HUMS) and
7 ecological sustainability (ECOS). HUMS and ECOS are in the second level. The
8 HUMS comprises four secondary components, including education (KNOW),
9 political aspects (POLICY), economic welfare (WEALTH) and health (HEALTH),
10 which are in the third level. ECOS also comprises four secondary components,
11 including land integrity (LAND), water quality (WATER), biodiversity (BIOD), and
12 air quality (AIR). Each secondary component can be divided into tertiary indicators,
13 PRESSURE (PR), STATE (ST), and RESPONSE (RE), which are in the fourth level.
14 A total of 75 basic indicators are used to describe tertiary indicators. Based on the
15 principle of the ANFIS and the hierarchical structure of sustainability assessment

1 proposed by Phillis et al. (2011), the hierarchical structure of ANFIS model is
2 developed, as shown in Figure 2.

3 *<Insert Figure 2 Here>*

4 As shown in Figure 2, there are also four levels of the ANFIS model, including
5 tertiary, secondary, primary and overall. Taking basic ANFIS 1 as an example, it
6 includes three basic indicators, “Primary education ratio of students to teaching staff”,
7 “Secondary education ratio of students to teaching staff” and “Tertiary education ratio
8 of students to teaching staff”. The normalized values of these three basic indicators
9 are the inputs, and the value of PRKNOW is the output. The output of ANFIS 1 is the
10 input of ANFIS 25 in the upper level. Similarly, there are 35 ANFIS models for
11 evaluating a country’s sustainability performance.

12 Step 2. Data collection

13 Phillis et al. (2011) and Grigoroudis et al. (2014) have applied the indicator
14 system to evaluate the sustainability performance of 128 countries over the period of
15 1990-2005 and 1990-2011, respectively. The research data and results of Phillis et al.
16 (2011) and Grigoroudis et al. (2014) will be used as the training and checking samples

1 for the 35 ANFIS models. Wang and Elhag (2008) suggested that the reasonable ratio
2 between training and checking samples should be 3:1. Moreover, in order to avoid
3 mixing the training data sets, the 2005 data set is employed to train and check ANFIS.
4 The sample set contains 128 groups of data for each ANFIS and is divided into two
5 sample sets, 102 groups for training and 26 groups for checking.

6 Step 3. Development of ANFIS models

7 In order to develop the ANFIS models, the initial membership functions are
8 required. As mentioned earlier in this paper, there are various membership functions
9 to describe the input variables, such as Gaussian, bell-shaped, sigmoid functions or
10 other shapes. In this study, the Gaussian membership function is used, and each input
11 has three fuzzy sets, namely, Weak, Medium and Strong. With the principle of equal
12 distribution, parameters of the initial three Gaussian fuzzy sets are generated by the
13 MATLAB software.

14 After generating the initial MFs of each variable, the ANFIS 1 model is
15 developed by using the fuzzy logic toolbox of MATLAB software package, as shown

1 in Figure 3. There are three input variables and each variable has three fuzzy sets with
2 overall 27 if-then fuzzy rules.

3 **<Insert Figure 3 Here>**

4 Step 4. Training and checking

5 In this stage of running the algorithm, the developed ANFIS 1 model will be
6 trained and checked by using training and checking samples. The detailed algorithm
7 of gradient method and the least-squares method can be found in Jang (1993). In
8 ANFIS 1, the normalized values of three basic indicators including “Primary
9 education ratio of students to teaching staff”, “Secondary education ratio of students
10 to teaching staff” and “Tertiary education ratio of students to teaching staff” are the
11 inputs, the value of PRKNOW is output. Each training data sample set comprises of
12 three inputs and one output. As mentioned before, there are 102 groups of training
13 samples. Figure 4 demonstrates the training process of ANFIS 1.

14 **<Insert Figure 4 Here>**

15 As shown in Figure 4, the initial epochs are set as 100 in this study, and the
16 training error of ANFIS 1 is only 0.0011002, which is much less than the minimum

1 requirement of training error < 0.1 (Sun et al., 2015). It also can be seen that the
2 training error is already close to zero when epochs are 30. After training, the fuzzy
3 rules were established and the initial MFs were improved. Figure 5 illustrates the MFs
4 before and after training process.

5 *<Insert Figure 5 Here>*

6 In Figure 5, it can be seen that the membership function type of three inputs is
7 still a Gaussian function. It indicates that the training process does not change the type
8 of membership function. However, the initial MFs were amended and improved after
9 training. It indicates the training process operates as an optimal process to make MFs
10 more closely reflect the real distribution of the training samples, since the initial
11 parameters of MFs are automatically generated from MATLAB with the principle of
12 equal distribution. In doing so, the assessment results are more accurate and
13 representative.

14 *<Insert Figure 6 Here>*

15 The surfaces of the trained ANFIS 1 model are shown in Figure 6, which
16 indicates the non-linear relationship between inputs and outputs. The left part

1 represents the solid surface of ANFIS in 3 dimensions, the x-axis and y-axis denote
2 the normalized values of two inputs out of three, and the z-axis denotes the
3 normalized value of output. The right part represents the projection surface of ANFIS
4 1 in 2 dimensions. The x-axis and y-axis also denote the normalized values of two
5 inputs out of three. The value of the output is illustrated by using different colors,
6 which changes from orange (for lower values) to red (for higher values).

7 After training the ANFIS model, the next step is to check the trained ANFIS
8 model. Taking ANFIS 1 as an example, Figure 7 presents the output comparison
9 between checking data and the ANFIS model.

10 **<Insert Figure 7 Here>**

11 As shown in Figure 7, “+” denotes the checking data, “*” denotes the output
12 derived from ANFIS model. Most outputs derived from ANFIS model can fit the
13 checking data. It indicates that ANFIS method is effective to assess the basic indicator,
14 PRKNOW.

15 The if-then rules of ANFIS 1 model were obtained after training, as shown in
16 Figure 8.

1 *<Insert Figure 8 Here>*

2 In Figure 8, input 1, input 2 and input 3 represent the normalized values of basic
3 indicators “Primary education ratio of students to teaching staff”, “Secondary
4 education ratio of students to teaching staff” and “Tertiary education ratio of students
5 to teaching staff”, respectively. The output is represented by the value of “PRKNOW”.

6 Taking the nation of Albania as an example, the values of inputs 1-3 in the Phillis et
7 al. (2011) dataset are (0.8895, 0.9235, 0.6477) respectively, and the output value is
8 0.896. As shown in Figure 8, the values of inputs 1-3 are (0.8895, 0.9235, 0.6477)
9 respectively, and the output of ANFIS 1 is 0.897, which differs from the SAFE model
10 by 0.1%.

11 In order to do the robust checking of these 35 ANFISs, five countries were
12 randomly selected from five different continents, including “Australia”, “Brazil”,
13 “Canada”, “China” and “France”, as the checking samples. The values of 75 basic
14 indicators in the year 2011 are chosen as the original inputs, and the output values
15 generated from the trained basic ANFIS are, in turn, used as the inputs of a secondary
16 ANFIS. For example, the outputs from ANFIS 1, 2 and 3 are the inputs of ANFIS 25,

1 the outputs from ANFIS 25, 26, 27 and 28 are the inputs of ANFIS 33, and the
2 outputs from 33 and 34 are the inputs of ANFIS 35. The checking results were
3 compared with the values in the SAFE model of Phillis et al (2011). The maximum
4 difference of outputs between SAFE and ANFIS models is 4.2%. For the overall
5 sustainability performance, the difference is less than 0.9%. It indicates that the 35
6 ANFIS models are effective with appropriate training.

7 **5 Discussion**

8 5.1 The comparison between SAFE and ANFIS assessment results

9 After training and checking, the 35 ANFIS models were used to re-assess the
10 overall sustainability performance of 128 countries in two discrete years, 2005 and
11 2011. The original ranking (SAFE) and the new ranking (ANFIS) are shown in Table
12 1.

13 *<Insert Table 1 Here>*

14 As shown in Table 1, it is noted that there are minor differences between SAFE
15 and the ANFIS. The largest difference belongs to the country “Uruguay” in 2011,
16 which ranks 26 in SAFE and ranks 20 in ANFIS. It is considered that the difference is

1 mainly due to the different membership function. The non-linear Gaussian
2 membership function used in ANFIS model better fits the real world problem
3 (Kreinovich et al., 1992). This advantage will be more obvious if the ANFIS model is
4 trained by appropriate samples. Thus, the ANFIS method is validated as being
5 appropriate for assessing the country sustainability performance.

6 5.2 The membership function optimization

7 As mentioned before, the assessment results vary due to different membership
8 functions. Therefore, different MFs will be tested in this section for selecting an
9 optimal one. Three different types of frequently employed non-linear membership
10 functions, including Gaussian, bell-shaped and sigmoidal membership functions were
11 selected for testing in this study (Bigand and Colot, 2016; Garg and Sharma, 2013;
12 Mohammadi et al., 2015; Pandit et al., 2015). The overall sustainability of 128
13 countries in 2005 and 2011 was assessed by ANFIS method with three types of
14 membership functions. The absolute difference of 128 countries' sustainability rank
15 between SAFE and ANFIS with three membership functions in year 2005 and 2011
16 are shown in Figure 9.

1 *<Insert Figure 9 Here>*

2 It can be seen that the difference between SAFE and ANFIS with Gaussian
3 membership function in both 2005 and 2011, are at a minimum when comparing with
4 the other two MFs. It indicates that ANFIS with Gaussian membership function is the
5 optimal one to reflect the original training data. Gaussian membership function is
6 commonly selected for fuzzy logic problems because it is the best to represent the real
7 distribution of various real problems (Bigand and Colot, 2016; Lin and Li, 2014;
8 Mouysset et al., 2012; Pandit et al., 2015; Sanchez et al., 2013). The research by
9 Kreinovich et al. (1992) revealed that the Gaussian membership function is the most
10 accurate in representing uncertainty in majority of real-life measure situations.
11 Rasmussen and Williams (2006) concluded that the Gaussian function is very natural
12 and can be used to define a distribution over functions. Singh (2013) further pointed
13 out that the Gaussian function can approximate any real continuous function on a
14 compact set to arbitrary accuracy.

15 5.3 Merits of ANFIS

16 From the above discussion, the merits of ANFIS can be concluded in the

1 following three aspects. First, sustainability is a very complex issue, which contains
2 various complicated non-linear relationships between variables (Hjorth and Bagheri
3 (2006). The ANFIS approach can easily handle the complex non-linear MFs and is
4 suitable for sustainability assessment. This study validates that the complex non-linear
5 MFs such as Gaussian, bell-shaped and sigmoid can be easily applied in ANFIS
6 models.

7 Second, the ANFIS has the advantage of time-saving especially in membership
8 function optimization. For traditional pre-defined membership functions, it is difficult
9 and time-consuming to execute the membership function optimization because each
10 membership function is based on experts' knowledge. Experts need to spend a lot of
11 time to define the parameters of each fuzzy set of MFs, which indicates that the more
12 MFs used in the country sustainability assessment system, the more difficult and time-
13 consuming it is. For ANFIS approach, it is easy to define the parameters and optimize
14 the MFs, and the process is time-saving because it is based on the data training rather
15 than the expert knowledge. The research by Khoshnevisan et al. (2014) echoed this
16 point that the time for recognizing membership functions and rules, and determining

1 proper size and optimal structure of the neural net can be reduced by using ANFIS.

2 Last, the ANFIS approach has great performance in solving those dynamic and
3 multi-criteria problems. Sustainability assessment includes dynamic and multi-criteria,
4 and different researchers may use different indicators and benchmarks (Phillis et al.,
5 2011; Shen et al., 2016). In order to establish a universal and comprehensive
6 assessment approach, these features should be considered. The ANFIS approach has
7 the adaptive learning ability, which makes it possible to solve the dynamic and multi-
8 criteria problems (Denai et al., 2004). This study demonstrates the ANFIS approach is
9 suitable for dynamic assessment of sustainability with appropriate training. Therefore,
10 more training data from various sources, such as World Bank, and UN-Habitat will be
11 collected for training, which makes the approach adapt to the changes in future.

12 **6 Conclusions**

13 For a better understanding of sustainability, there is a need for an effective
14 sustainability assessment method. Many methods have been adopted for sustainability
15 assessment, including fuzzy logic. Currently, pre-defined simple linear fuzzy
16 membership functions and if-then rules have been widely used in existing studies.

1 However, the pre-defined MFs and rules have limitations because they are only based
2 on experts' knowledge. Thus, to overcome these limitations, this study applied the
3 adaptive neuro-fuzzy inference system (ANFIS) to assess sustainability of countries.
4 The results show that, compared to earlier studies, the ANFIS method is appropriate
5 to measure the countries' sustainability performance with appropriate training data.
6 Furthermore, the ANFIS method can also be used for sustainability assessment in
7 different levels, including city level, industrial level or project level in future studies.

8 The training data is important for the successful application of ANFIS method.

9 In this study, we have relied on only one data source, the SAFE dataset, which is one
10 limitation of this study. The assessment results from ANFIS are very close to those
11 generated from the SAFE model, indicating the effectiveness of the ANFIS method.

12 In order to model behavior that better reflects the real world, there is a need for an
13 appropriate selection of training data. Thus, the accuracy of the ANFIS method, as
14 already shown in this study, can be further improved in further study by collecting
15 training data from different sources, such as UN-Habitat, or World Bank.

16 Furthermore, the whole domain of sustainability assessment is currently part of a

1 dynamic process. Consequently, it is expected that the indicators, benchmarks, or
2 rules may change with the changing environment. The ANFIS method has the
3 potential to perform better than other methods due to its adaptive learning ability,
4 but this needs to be demonstrated through new training, with new collected data.

5 **Acknowledgements**

6 This research was fully supported by a grant from the Research Grants Council of
7 Hong Kong Special Administrative Region, China (Project No. F-PP2F). The authors
8 would like to thank Prof. Yannis A. Phillis (Technical University of Crete) and Prof.
9 Vassilis S. Kouikoglou (Technical University of Crete) for providing the training data.
10 The authors would also like to acknowledge the editing by Dr. Paul W. Fox of an
11 earlier draft of this paper.

12 **References**

- 13 Abdulshahed, A.M., Longstaff, A.P., Fletcher, S., 2015. The application of ANFIS
14 prediction models for thermal error compensation on CNC machine tools. *Applied*
15 *Soft Computing* 27, 158-168.
- 16 Andriantiatsaholiniaina, L.A., Kouikoglou, V.S., Phillis, Y.A., 2004. Evaluating
17 strategies for sustainable development: fuzzy logic reasoning and sensitivity analysis.
18 *Ecological Economics* 48, 149-172.
- 19 Bigand, A., Colot, O., 2016. Membership function construction for interval-valued
20 fuzzy sets with application to Gaussian noise reduction. *Fuzzy Sets and Systems* 286,
21 66-85.

1 Bond, A.J., Morrison-Saunders, A., 2011. Re-evaluating sustainability assessment:
2 aligning the vision and the practice. *Environmental Impact Assessment Review* 31, 1-
3 7.

4 Brundtland, C., 1987. *Our common future*. Oxford: Oxford University Press.

5 Cavallaro, F., 2015. A Takagi-Sugeno Fuzzy Inference System for Developing a
6 Sustainability Index of Biomass. *Sustainability* 7, 12359-12371.

7 Chen, X., Lu, W., 2017. Identifying factors influencing demolition waste generation
8 in Hong Kong. *Journal of Cleaner Production* 141, 799-811.

9 Cornelissen, A.M.G., Van den Berg, J., Koops, W.J., Grossman, M., Udo, H.M.J.,
10 2001. Assessment of the contribution of sustainability indicators to sustainable
11 development: a novel approach using fuzzy set theory. *Agriculture, ecosystems &*
12 *environment* 86, 173-185.

13 Coteur, I., Marchand, F., Debruyne, L., Dalemans, F., Lauwers, L., 2016. A
14 framework for guiding sustainability assessment and on-farm strategic decision
15 making. *Environmental Impact Assessment Review* 60, 16-23.

16 Denai, M.A., Palis, F., Zeghib, A., 2004. ANFIS based modelling and control of
17 non-linear systems: a tutorial, *Systems, Man and Cybernetics*, 2004 IEEE
18 International Conference on. IEEE, pp. 3433-3438.

19 Devuyst, D., Hens, L., De Lannoy, W., 2001. *How green is the city?: sustainability*
20 *assessment and the management of urban environments*. Columbia University Press.

21 Dor, A., Kissinger, M., 2017. A multi-year, multi-scale analysis of urban
22 sustainability. *Environmental Impact Assessment Review* 62, 115-121.

23 Garg, H., Sharma, S.P., 2013. Multi-objective reliability-redundancy allocation
24 problem using particle swarm optimization. *Computers & Industrial Engineering* 64,
25 247-255.

26 Government of Mexico City, 2007. Green plan “Plan Verde” (in Spanish).

27 Grigoroudis, E., Kouikoglou, V.S., Phillis, Y.A., 2014. SAFE 2013: Sustainability of
28 countries updated. *Ecological Indicators* 38, 61-66.

29 Guan, D., Hubacek, K., Weber, C.L., Peters, G.P., Reiner, D.M., 2008. The drivers of
30 Chinese CO₂ emissions from 1980 to 2030. *Global Environmental Change* 18, 626-
31 634.

32 Hashemi, A., Pilevar, A.H., Rafeh, R., 2013. Mass Detection in Lung CT Images
33 Using Region Growing Segmentation and Decision Making Based on Fuzzy

1 Inference System and Artificial Neural Network. *International Journal of Image,*
2 *Graphics and Signal Processing* 5, 16.

3 Hegde, A.V., Raju, B., 2015. Conventional Prediction vs Beyond Data Range
4 Prediction of Loss Coefficient for Quarter Circle Breakwater Using ANFIS, *Advances*
5 *in Computational Intelligence*. Springer, pp. 412-421.

6 Hjorth, P., Bagheri, A., 2006. Navigating towards sustainable development: A system
7 dynamics approach. *Futures* 38, 74-92.

8 Hong Kong Planning Department, 2007. Hong Kong 2030 planning vision and
9 strategy.

10 Houshyar, E., SheikhDavoodi, M.J., Almassi, M., Bahrami, H., Azadi, H., Omid, M.,
11 Sayyad, G., Witlox, F., 2014. Silage corn production in conventional and
12 conservation tillage systems. Part I: sustainability analysis using combination of
13 GIS/AHP and multi-fuzzy modeling. *Ecological Indicators* 39, 102-114.

14 Inyang, U.G., Akinyokun, O.C., 2014. A hybrid knowledge discovery system for oil
15 spillage risks pattern classification. *Artificial Intelligence Research* 3, p77.

16 Iribarren, D., Martín-Gamboa, M., O'Mahony, T., Dufour, J., 2016. Screening of
17 socio-economic indicators for sustainability assessment: a combined life cycle
18 assessment and data envelopment analysis approach. *The International Journal of Life*
19 *Cycle Assessment* 21, 202-214.

20 Jang, J.-S.R., 1993. ANFIS: adaptive-network-based fuzzy inference system. *Systems,*
21 *Man and Cybernetics*, IEEE Transactions on 23, 665-685.

22 Jayaraman, R., Liuzzi, D., Colapinto, C., Malik, T., 2015. A fuzzy goal programming
23 model to analyze energy, environmental and sustainability goals of the United Arab
24 Emirates. *Annals of Operations Research*, 1-16.

25 Jiao, L., Shen, L., Shuai, C., He, B., 2016. A Novel Approach for Assessing the
26 Performance of Sustainable Urbanization Based on Structural Equation Modeling: A
27 China Case Study. *Sustainability* 8, 910.

28 Karami, S., Karami, E., Buys, L., Drogemuller, R., 2017. System dynamic simulation:
29 A new method in social impact assessment (SIA). *Environmental Impact Assessment*
30 *Review* 62, 25-34.

31 Khoshnevisan, B., Rafiee, S., Omid, M., Mousazadeh, H., Clark, S., 2014.
32 Environmental impact assessment of tomato and cucumber cultivation in greenhouses
33 using life cycle assessment and adaptive neuro-fuzzy inference system. *Journal of*

1 Cleaner Production 73, 183-192.

2 Kouikoglou, V.S., Phillis, Y.A., 2011. Application of a fuzzy hierarchical model to
3 the assessment of corporate social and environmental sustainability. Corporate Social
4 Responsibility and Environmental Management 18, 209-219.

5 Kouloumpis, V.D., Kouikoglou, V.S., Phillis, Y.A., 2008. Sustainability assessment
6 of nations and related decision making using fuzzy logic. Systems Journal, IEEE 2,
7 224-236.

8 Kreinovich, V., Quintana, C., Reznik, L., 1992. Gaussian membership functions are
9 most adequate in representing uncertainty in measurements, Proceedings of NAFIPS,
10 pp. 15-17.

11 Li, Z.-f., Li, Y.-l., 2009. An Empirical Study on Performance Evaluation of
12 Infrastructure Investment of China Based on DEA Method from 2003 to 2007 [J].
13 Journal of Systems & Management 18(3), 309-315.

14 Lin, C.-M., Li, H.-Y., 2014. Adaptive dynamic sliding-mode fuzzy CMAC for voice
15 coil motor using asymmetric Gaussian membership function. IEEE transactions on
16 industrial electronics 61, 5662-5671.

17 Liu, B., Shen, Y., Chen, X., Sun, H., Chen, Y., 2014. A complex multi-attribute large-
18 group PLS decision-making method in the interval-valued intuitionistic fuzzy
19 environment. Applied Mathematical Modelling 38, 4512-4527.

20 Lu, W., Chen, X., Ho, D.C.W., Wang, H., 2016. Analysis of the construction waste
21 management performance in Hong Kong: the public and private sectors compared
22 using big data. Journal of Cleaner Production 112, 521-531.

23 Lu, W., Chen, X., Peng, Y., Shen, L., 2015. Benchmarking construction waste
24 management performance using big data. Resources, Conservation and Recycling 105,
25 49-58.

26 Melbourne City Council, 2001. City plan 2010-towards a thriving and sustainable city
27 [http://www.melbourne.vic.gov.au/rsrc/PDFs/Publications/CityPlan2010_part1.](http://www.melbourne.vic.gov.au/rsrc/PDFs/Publications/CityPlan2010_part1.pdf)
28 [pdf.](http://www.melbourne.vic.gov.au/rsrc/PDFs/Publications/CityPlan2010_part1.pdf)

29 Mendoza, G.A., Prabhu, R., 2003. Qualitative multi-criteria approaches to assessing
30 indicators of sustainable forest resource management. Forest ecology and
31 management 174, 329-343.

32 Moghaddamnia, A., Gousheh, M.G., Piri, J., Amin, S., Han, D., 2009. Evaporation
33 estimation using artificial neural networks and adaptive neuro-fuzzy inference system

1 techniques. *Advances in Water Resources* 32, 88-97.

2 Mohammadi, K., Shamshirband, S., Tong, C.W., Alam, K.A., Petković, D., 2015.

3 Potential of adaptive neuro-fuzzy system for prediction of daily global solar radiation

4 by day of the year. *Energy Conversion and Management* 93, 406-413.

5 Mohandes, M., Rehman, S., Rahman, S.M., 2011. Estimation of wind speed profile

6 using adaptive neuro-fuzzy inference system (ANFIS). *Applied Energy* 88, 4024-

7 4032.

8 Mouysset, L., Doyen, L., Jiguet, F., 2012. Different policy scenarios to promote

9 various targets of biodiversity. *Ecological Indicators* 14, 209-221.

10 Naderloo, L., Alimardani, R., Omid, M., Sarmadian, F., Javadikia, P., Torabi, M.Y.,

11 Alimardani, F., 2012. Application of ANFIS to predict crop yield based on different

12 energy inputs. *Measurement* 45, 1406-1413.

13 Ness, B., Urbel-Piirsalu, E., Anderberg, S., Olsson, L., 2007. Categorising tools for

14 sustainability assessment. *Ecological economics* 60, 498-508.

15 North Atlantic Treaty Organization (NATO), 2004. Istanbul Summit.

16 Onat, N.C., Kucukvar, M., Tatari, O., Egilmez, G., 2016. Integration of system

17 dynamics approach toward deepening and broadening the life cycle sustainability

18 assessment framework: a case for electric vehicles. *The International Journal of Life*

19 *Cycle Assessment*, 1-26.

20 Özkan, G., Inal, M., 2014. Comparison of neural network application for fuzzy and

21 ANFIS approaches for multi-criteria decision making problems. *Applied Soft*

22 *Computing* 24, 232-238.

23 Pandit, M., Chaudhary, V., Dubey, H.M., Panigrahi, B.K., 2015. Multi-period wind

24 integrated optimal dispatch using series PSO-DE with time-varying Gaussian

25 membership function based fuzzy selection. *International Journal of Electrical Power*

26 *& Energy Systems* 73, 259-272.

27 Peng, Y., 2015. A comparison of two approaches to develop concentrated rural

28 settlements after the 5.12 Sichuan Earthquake in China. *Habitat International* 49, 230-

29 242.

30 Phillis, Y.A., Andriantiatsaholiniaina, L.A., 2001. Sustainability: an ill-defined

31 concept and its assessment using fuzzy logic. *Ecological Economics* 37, 435-456.

32 Phillis, Y.A., Grigoroudis, E., Kouikoglou, V.S., 2011. Sustainability ranking and

33 improvement of countries. *Ecological Economics* 70, 542-553.

1 Phillis, Y.A., Kouikoglou, V.S., 2009. Fuzzy measurement of sustainability. Nova
2 Science Publishers.

3 Rasmussen, C.E., Williams, C.K.I., 2006. Gaussian processes for machine learning.
4 The MIT Press.

5 Ratnayake, R.M.C., 2014. Application of a fuzzy inference system for functional
6 failure risk rank estimation: RBM of rotating equipment and instrumentation. Journal
7 of Loss Prevention in the Process Industries 29, 216-224.

8 Retief, F., Bond, A., Pope, J., Morrison-Saunders, A., King, N., 2016. Global
9 megatrends and their implications for environmental assessment practice.
10 Environmental Impact Assessment Review 61, 52-60.

11 Sanchez, M.A., Castro, J.R., Castillo, O., 2013. Formation of general type-2 Gaussian
12 membership functions based on the information granule numerical evidence, 2013
13 IEEE Workshop on Hybrid Intelligent Models and Applications (HIMA). IEEE, pp.
14 1-6.

15 Sangaiah, A.K., Thangavelu, A.K., Gao, X.Z., Anbazhagan, N., Durai, M.S., 2015.
16 An ANFIS approach for evaluation of team-level service climate in GSD projects
17 using Taguchi-genetic learning algorithm. Applied Soft Computing 30, 628-635.

18 Santana, N.B., Aparecida do Nascimento Rebelatto, D., Périco, A.E., Mariano, E.B.,
19 2014. Sustainable development in the BRICS countries: an efficiency analysis by data
20 envelopment. International Journal of Sustainable Development & World Ecology 21,
21 259-272.

22 Shen, L., Peng, Y., Zhang, X., Wu, Y., 2012. An alternative model for evaluating
23 sustainable urbanization. Cities 29, 32-39.

24 Shen, L., Shuai, C., Jiao, L., Tan, Y., Song, X., 2016. A Global Perspective on the
25 Sustainable Performance of Urbanization. Sustainability 8, 783.

26 Shen, L., Shuai, C., Jiao, L., Tan, Y., Song, X., 2017. Dynamic sustainability
27 performance during urbanization process between BRICS countries. Habitat
28 International 60, 19-33.

29 Shen, L., Zhou, J., Skitmore, M., Xia, B., 2015. Application of a hybrid Entropy–
30 McKinsey Matrix method in evaluating sustainable urbanization: A China case study.
31 Cities 42, 186-194.

32 Shuai, C., Shen, L., Jiao, L., Wu, Y., Tan, Y., 2017. Identifying key impact factors on
33 carbon emission: Evidences from panel and time-series data of 125 countries from

1 1990 to 2011. Applied Energy 187, 310-325.

2 Singh, R., Kainthola, A., Singh, T.N., 2012. Estimation of elastic constant of rocks
3 using an ANFIS approach. Applied Soft Computing 12, 40-45.

4 Singh, V.K., 2013. Approximations of Fuzzy Systems. Indonesian Journal of
5 Electrical Engineering and Informatics (IJEEI) 1, 14-20.

6 Strezov, V., Evans, A., Evans, T.J., 2016. Assessment of the Economic, Social and
7 Environmental Dimensions of the Indicators for Sustainable Development.
8 Sustainable Development.

9 Sugeno, M., 1985. Industrial applications of fuzzy control. Elsevier Science Inc.

10 Sun, W., Hu, P., Lei, F., Zhu, N., Jiang, Z., 2015. Case study of performance
11 evaluation of ground source heat pump system based on ANN and ANFIS models.
12 Applied Thermal Engineering 87, 586-594.

13 Tan, Y., Ochoa, J.J., Langston, C., Shen, L., 2015. An empirical study on the
14 relationship between sustainability performance and business competitiveness of
15 international construction contractors. Journal of Cleaner Production 93, 273-278.

16 Tan, Y., Shen, L., Langston, C., 2014. A fuzzy approach for adaptive reuse selection
17 of industrial buildings in Hong Kong. International Journal of Strategic Property
18 Management 18, 66-76.

19 Tan, Y., Shen, L., Yao, H., 2011. Sustainable construction practice and contractors'
20 competitiveness: A preliminary study. Habitat International 35, 225-230.

21 Tan, Y., Xu, H., Zhang, X., 2016. Sustainable urbanization in China: A
22 comprehensive literature review. Cities 55, 82-93.

23 UN-Habitat, 2016. The New Urban Agenda. [http://habitat3.org/the-new-urban-
agenda/](http://habitat3.org/the-new-urban-
24 agenda/).

25 United Nations, 2016. Transforming our world: the 2030 Agenda for Sustainable
26 Development.
27 http://www.un.org/ga/search/view_doc.asp?symbol=A/RES/70/1&Lang=E.

28 Veldhuizen, L.J.L., Berentsen, P.B.M., Bokkers, E.A.M., de Boer, I.J.M., 2015. A
29 method to assess social sustainability of capture fisheries: An application to a
30 Norwegian trawler. Environmental Impact Assessment Review 53, 31-39.

31 Wang, Y.-M., Elhag, T.M.S., 2008. An adaptive neuro-fuzzy inference system for
32 bridge risk assessment. Expert Systems with Applications 34, 3099-3106.

33 Wende, W., Bond, A., Bobylev, N., Stratmann, L., 2012. Climate change mitigation

1 and adaptation in strategic environmental assessment. *Environmental Impact*
2 *Assessment Review* 32, 88-93.

3 Yan, H., Wei, Q., Hao, G., 2002. DEA models for resource reallocation and
4 production input/output estimation. *European Journal of Operational Research* 136,
5 19-31.

6 Yigitcanlar, T., Dur, F., Dizdaroglu, D., 2015. Towards prosperous sustainable cities:
7 A multiscale urban sustainability assessment approach. *Habitat International* 45, 36-
8 46.

9 Yu, Y., Wen, Z., 2010. Evaluating China's urban environmental sustainability with
10 Data Envelopment Analysis. *Ecological Economics* 69, 1748-1755.

11 Zhao, H., Li, N., 2016. Performance Evaluation for Sustainability of Strong Smart
12 Grid by Using Stochastic AHP and Fuzzy TOPSIS Methods. *Sustainability* 8, 129.

13 Zhou, J., Shen, L., Song, X., Zhang, X., 2015a. Selection and modeling sustainable
14 urbanization indicators: A responsibility-based method. *Ecological Indicators* 56, 87-
15 95.

16 Zhou, J., Zhang, X., Shen, L., 2015b. Urbanization bubble: Four quadrants
17 measurement model. *Cities* 46, 8-15.

18 Zhou, Y., Li, Y.P., Huang, G.H., 2015c. Planning sustainable electric-power system
19 with carbon emission abatement through CDM under uncertainty. *Applied Energy*
20 140, 350-364.

21
22
23
24
25
26
27
28
29
30

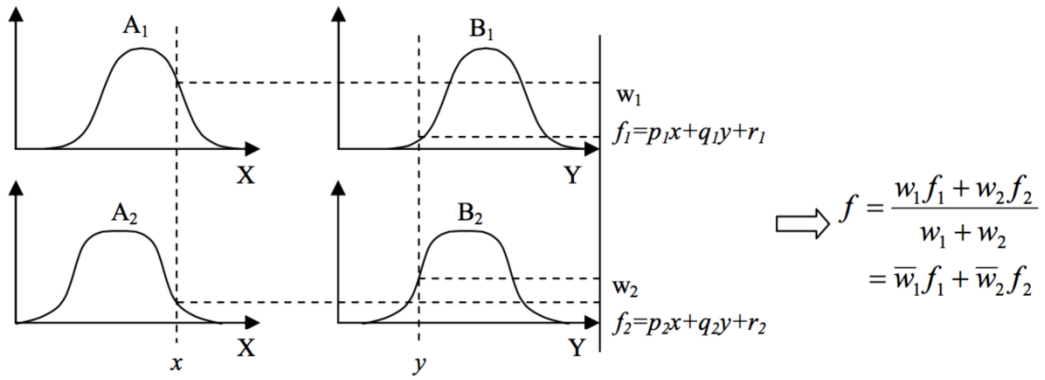

1
 2 Figure 1(a) A first order Takagi-Sugeno fuzzy model with two inputs and two rules
 3 (Jang, 1993)

4

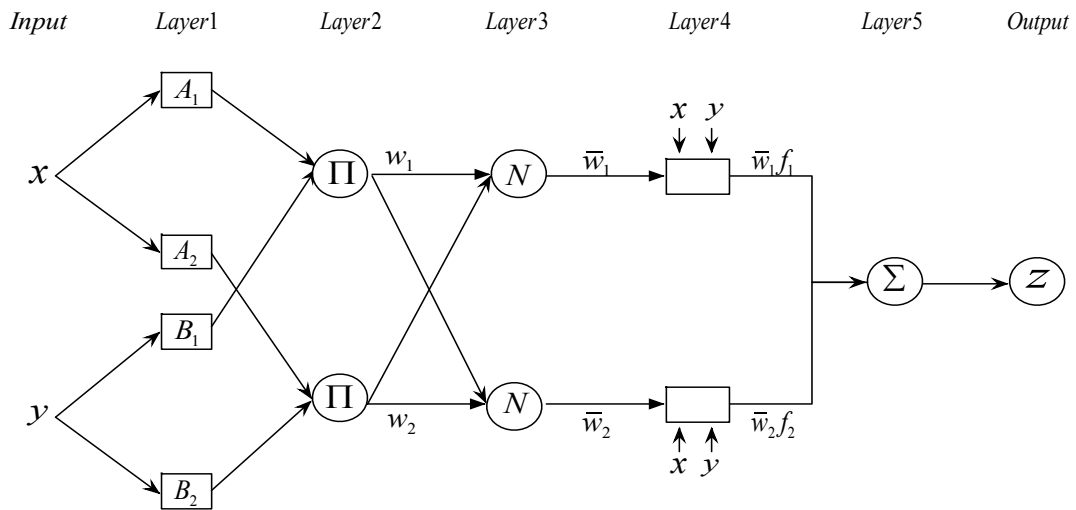

5

6 Figure 1(b) The equivalent ANFIS architecture (Jang, 1993)

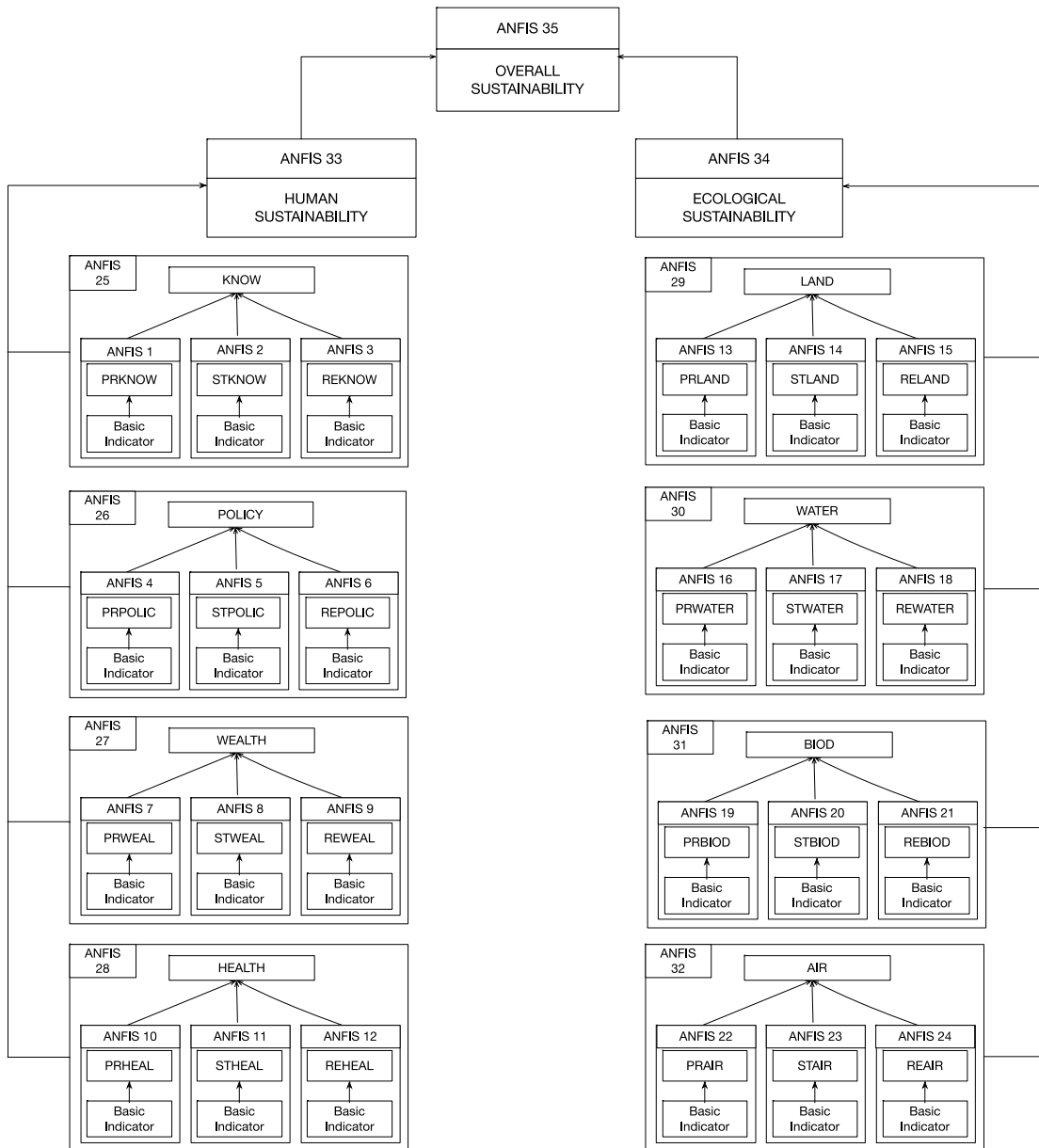

- 1
- 2
- 3
- 4
- 5
- 6
- 7

Figure 2 Assessment framework of sustainability performance

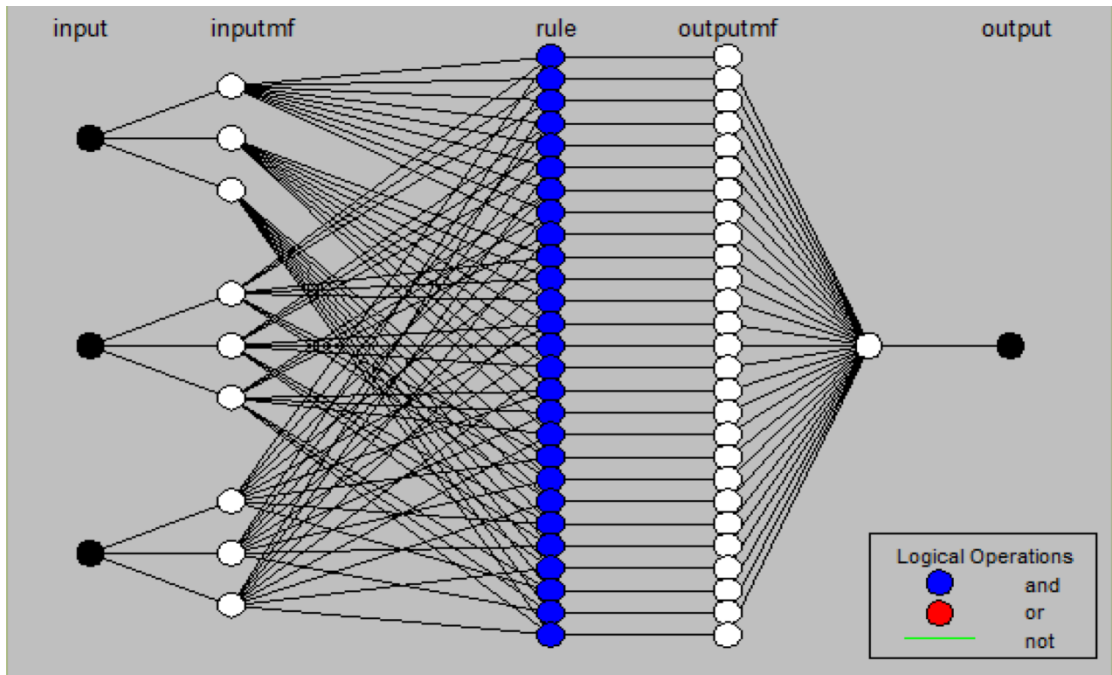

1

2

Figure 3 FIS structure of ANFIS 1 in MATLAB

3

4

5

6

7

8

9

10

11

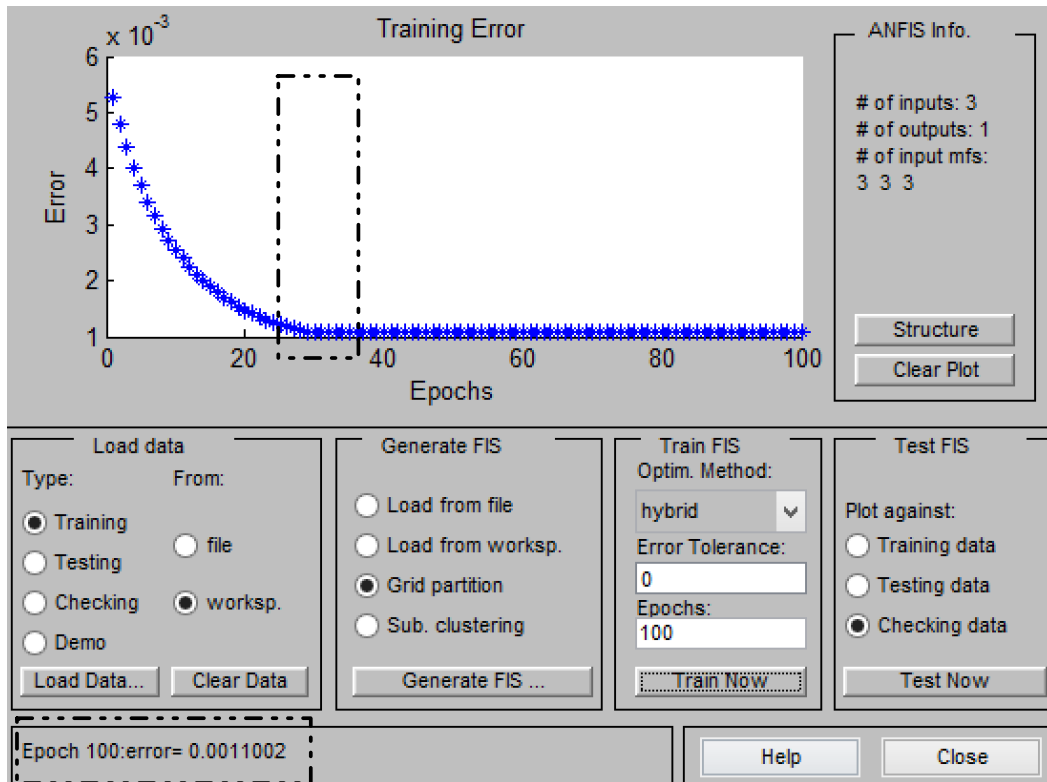

1

2

Figure 4 Training process of ANFIS 1

3

4

5

6

7

8

9

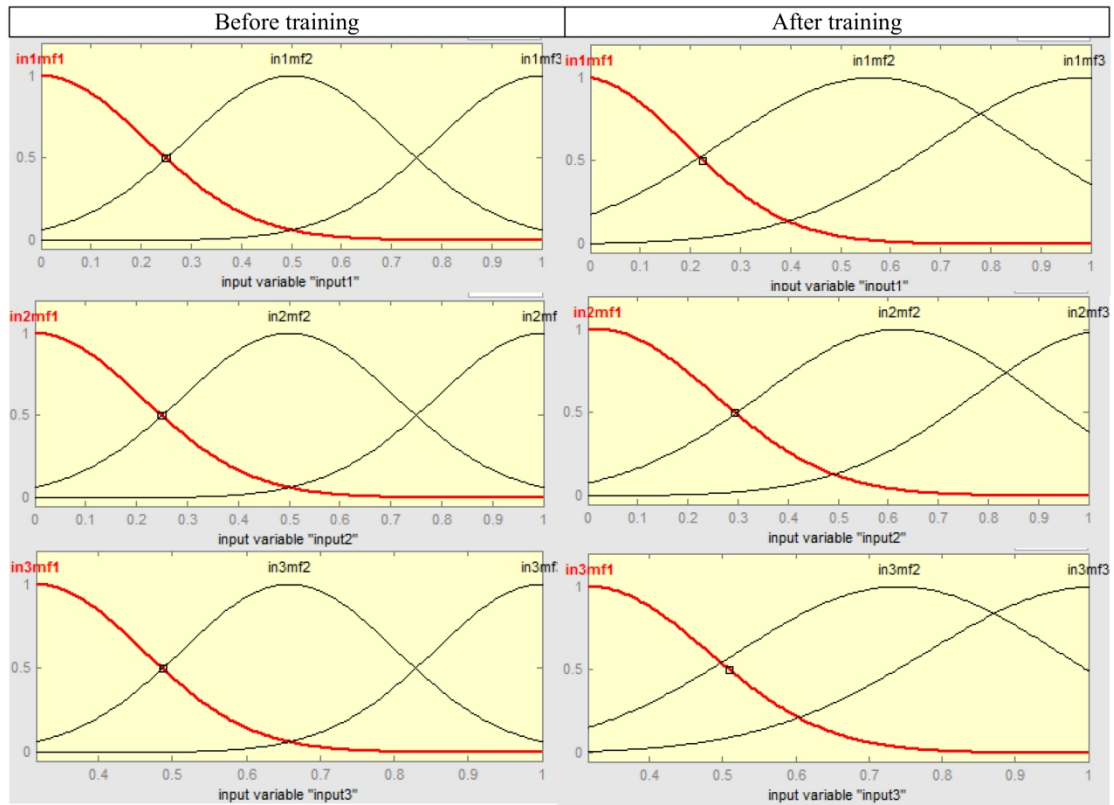

1

2

Figure 5 Membership functions of ANFIS 1 before and after training

3

4

5

6

7

8

9

10

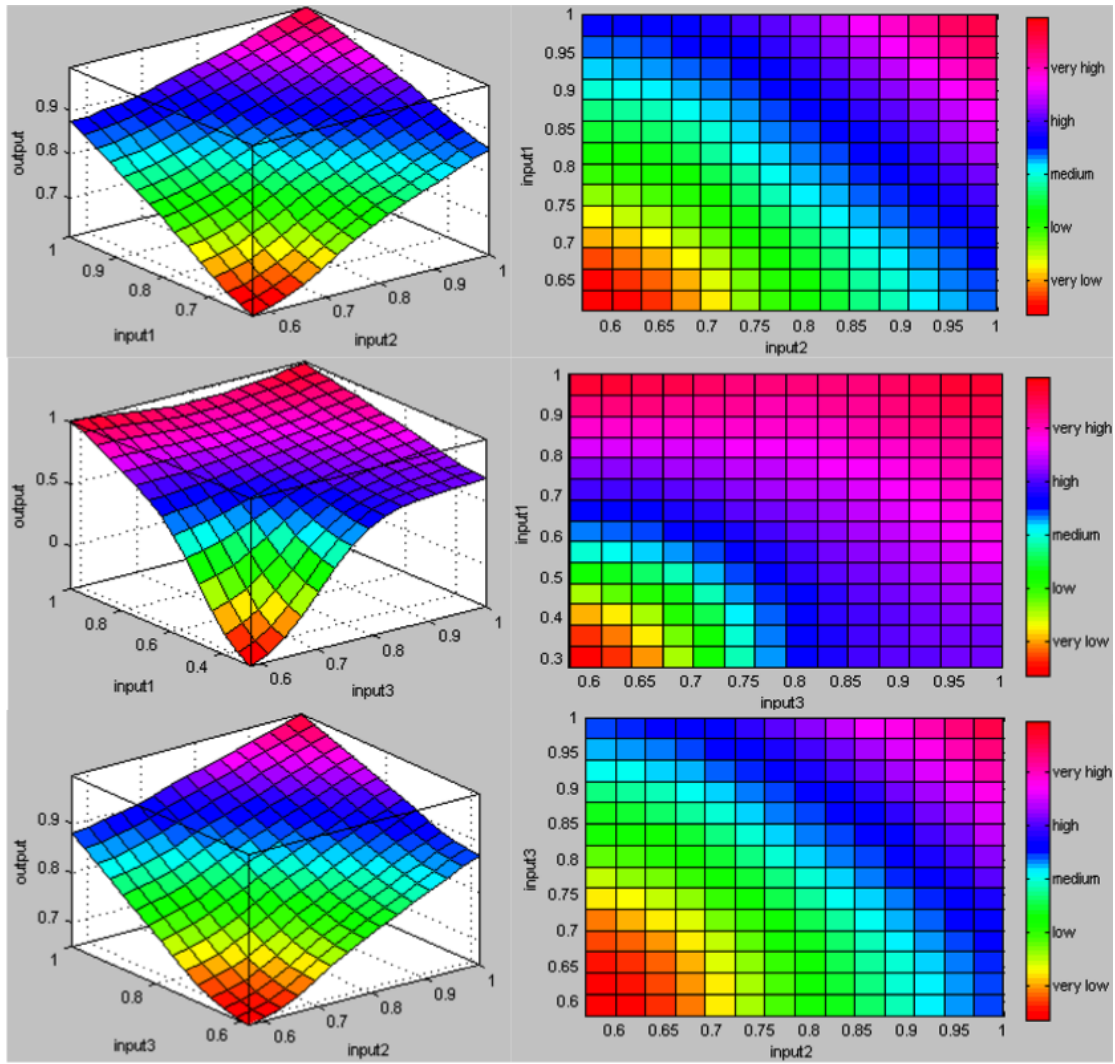

1

2

Figure 6 Surfaces of ANFIS 1 model

3

4

5

6

7

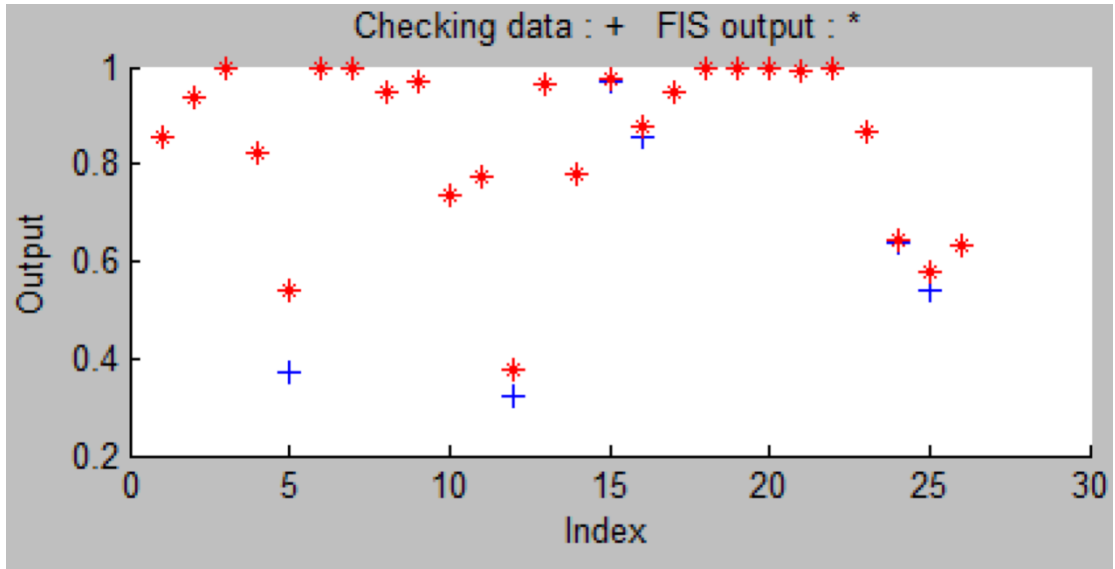

1

2

Figure 7 Comparison between checking data and the ANFIS

3

4

5

6

7

8

9

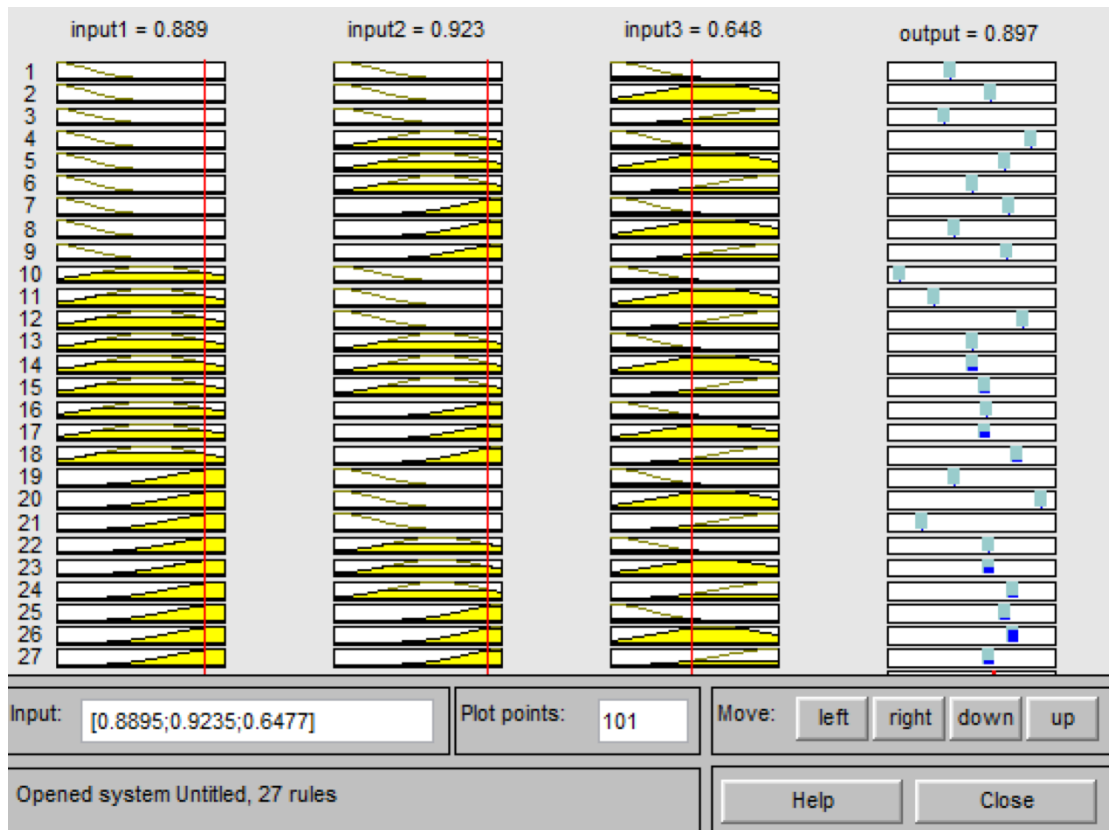

1

2

Figure 8 If-then rules after training

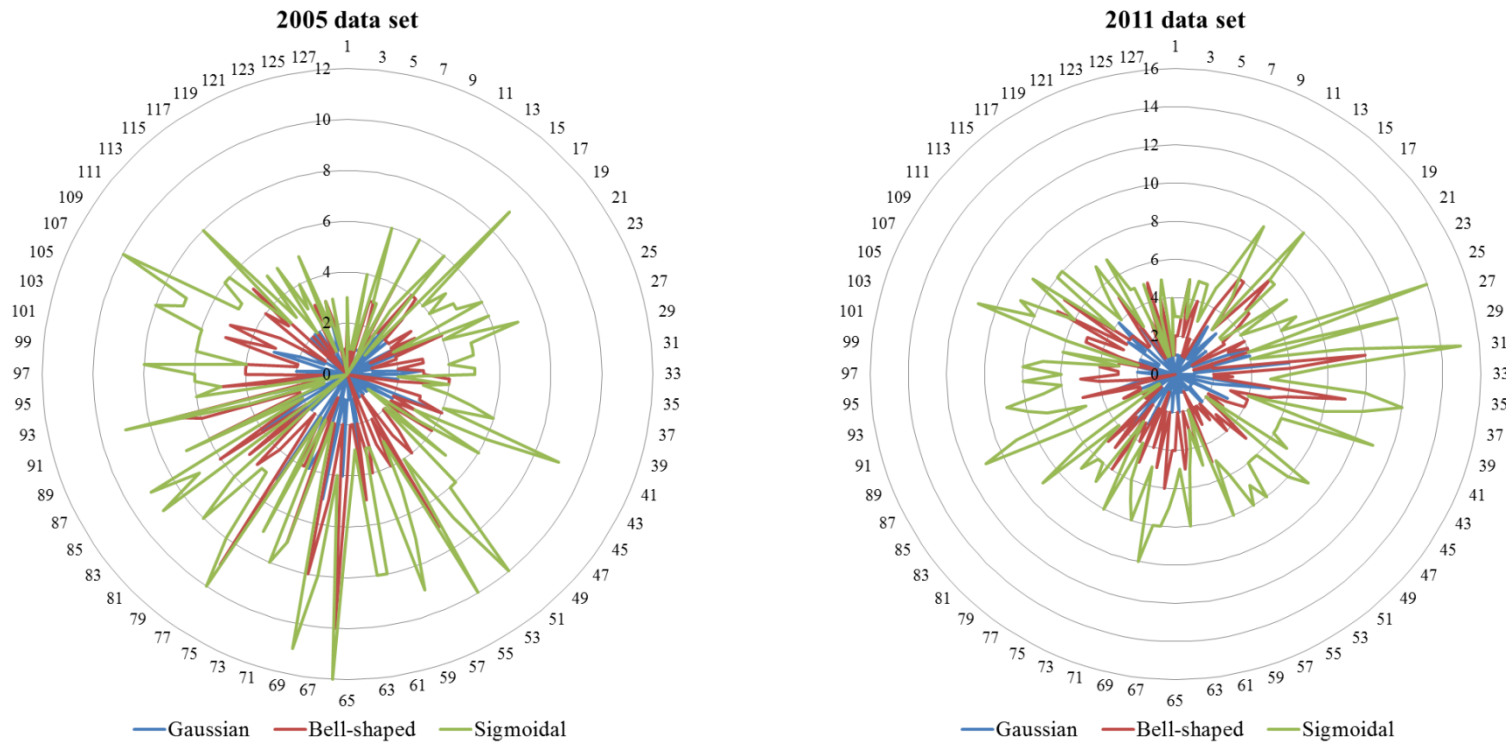

Figure 9 The absolute difference of rank between SAFE and ANFIS with three MFs in year 2005 and 2011

Table 1 Sustainability ranking by SAFE and ANFIS

Country	Ranking (2005)			Ranking (2011)		
	SAFE	ANFIS	Difference	SAFE	ANFIS	Difference
Switzerland	1	2	1	2	3	1
Sweden	2	1	-1	3	2	-1
Finland	3	3	0	5	6	1
Denmark	4	4	0	6	5	-1
Norway	5	5	0	4	4	0
Austria	6	6	0	7	8	1
France	7	8	1	10	11	1
Netherlands	8	7	-1	8	7	-1
Germany	9	10	1	1	1	0
Belgium	10	9	-1	9	9	0
Canada	11	13	2	13	13	0
New Zealand	12	12	0	11	10	-1
Latvia	13	11	-2	18	21	3
Estonia	14	15	1	25	23	-2
Lithuania	15	18	3	15	16	1
Italy	16	16	0	17	19	2
Slovakia	17	14	-3	20	17	-3
Czech Rep.	18	19	1	16	15	-1
Australia	19	17	-2	14	14	0
Portugal	20	20	0	24	22	-2
Croatia	21	21	0	29	28	-1
UK	22	23	1	12	12	0
Poland	23	25	2	23	24	1
Hungary	24	24	0	33	32	-1
Greece	25	22	-3	31	30	-1
Spain	26	27	1	21	25	4
Japan	27	26	-1	28	31	3

Ireland	28	28	0	22	26	4
USA	29	30	1	32	33	1
Slovenia	30	29	-1	19	18	-1
Uruguay	31	32	1	26	20	-6
Chile	32	35	3	45	44	-1
Bulgaria	33	31	-2	36	37	1
Georgia	34	34	0	42	42	0
Israel	35	33	-2	49	48	-1
South Korea	36	36	0	48	53	5
Panama	37	37	0	43	46	3
Malaysia	38	38	0	57	55	-2
Belarus	39	39	0	27	27	0
Albania	40	40	0	44	43	-1
Bolivia	41	45	4	56	57	1
Tunisia	42	42	0	55	58	3
Thailand	43	41	-2	64	64	0
Venezuela	44	43	-1	51	50	-1
Romania	45	44	-1	30	29	-1
Paraguay	46	46	0	53	52	-1
Ukraine	47	48	1	39	38	-1
FYR Maced.	48	47	-1	38	39	1
Peru	49	49	0	61	59	-2
El Salvador	50	50	0	58	56	-2
Brazil	51	52	1	35	35	0
Moldova	52	51	-1	66	65	-1
Nicaragua	53	53	0	50	49	-1
Kazakhstan	54	54	0	40	40	0
Argentina	55	56	1	34	34	0
Kyrgyzstan	56	55	-1	54	54	0
Ecuador	57	58	1	46	45	-1

Armenia	58	57	-1	52	51	-1
Azerbaijan	59	60	1	68	67	-1
Russia	60	61	1	41	41	0
Vietnam	61	59	-2	81	82	1
Jordan	62	66	4	76	75	-1
Mongolia	63	63	0	75	77	2
Mexico	64	65	1	60	60	0
China	65	64	-1	62	63	1
Syria	66	62	-4	73	73	0
Kuwait	67	68	1	59	61	2
Turkey	68	67	-1	37	36	-1
Saudi Arabia	69	74	5	79	78	-1
Botswana	70	70	0	71	72	1
Algeria	71	73	2	83	85	2
Morocco	72	75	3	47	47	0
Uzbekistan	73	69	-4	80	79	-1
Gambia	74	71	-3	90	90	0
Congo	75	77	2	95	92	-3
Gabon	76	76	0	82	81	-1
Colombia	77	72	-5	105	105	0
Lebanon	78	78	0	93	94	1
Egypt	79	79	0	92	96	4
Zimbabwe	80	80	0	70	69	-1
Senegal	81	83	2	94	91	-3
Namibia	82	81	-1	77	76	-1
Zambia	83	86	3	88	87	-1
Malawi	84	82	-2	86	88	2
Papua NG	85	89	4	118	118	0
Oman	86	84	-2	115	115	0
Ghana	87	87	0	69	70	1
Honduras	88	85	-3	67	68	1

Sri Lanka	89	88	-1	87	89	2
Kenya	90	91	1	84	84	0
Cambodia	91	90	-1	117	117	0
Angola	92	95	3	101	104	3
Cote d'Ivoire	93	93	0	99	97	-2
Bangladesh	94	94	0	123	122	-1
Benin	95	92	-3	120	120	0
Laos	96	96	0	112	111	-1
Guatemala	97	97	0	72	71	-1
South Africa	98	100	2	85	83	-2
Philippines	99	98	-1	74	74	0
Chad	100	99	-1	102	103	1
United Arab E	101	101	0	78	80	2
Niger	102	103	1	124	124	0
Tanzania	103	106	3	104	102	-2
Uganda	104	102	-2	108	107	-1
Nigeria	105	104	-1	110	112	2
Togo	106	107	1	111	110	-1
Tajikistan	107	105	-2	63	62	-1
Indonesia	108	108	0	65	66	1
Guinea Bissau	109	109	0	97	100	3
Centr. Afr. R	110	110	0	121	123	2
Mozambique	111	112	1	96	93	-3
Rwanda	112	113	1	91	95	4
Madagascar	113	111	-2	114	114	0
Burkina Faso	114	114	0	98	98	0
Cameroon	115	117	2	113	113	0
Nepal	116	116	0	89	86	-3

Mali	117	115	-2	122	121	-1
Iran	118	118	0	103	101	-2
Guinea	119	119	0	100	99	-1
DR Congo	120	122	2	106	108	2
India	121	120	-1	116	116	0
Yemen	122	123	1	126	125	-1
Ethiopia	123	121	-2	119	119	0
Pakistan	124	125	1	125	126	1
Sierra Leone	125	124	-1	109	109	0
Burundi	126	126	0	107	106	-1
Mauritania	127	127	0	128	127	-1
Sudan	128	128	0	127	128	1

Highlights

- An ANFIS method is introduced for measuring country sustainability.
- 128 countries are re-assessed and the new ranking is close to SAFE model.
- The results show that Gaussian membership function fits the real world best..
- Appropriate selection of training data is important for the success of ANFIS method.