

Energy harvesting with piezoelectric drum transducer

Sheng Wang^{a)}

Department of Applied Physics, The Hong Kong Polytechnic University, Hung Hom, Kowloon, Hong Kong, China; Materials Research Centre, The Hong Kong Polytechnic University, Hung Hom, Kowloon, Hong Kong, China; and Department of Physics, Wuhan University, Wuhan 430072, China

Kwok Ho Lam, Cheng Liang Sun, Kin Wing Kwok, and Helen Lai Wa Chan

Department of Applied Physics, The Hong Kong Polytechnic University, Hung Hom, Kowloon, Hong Kong, China and Materials Research Centre, The Hong Kong Polytechnic University, Hung Hom, Kowloon, Hong Kong, China

Ming Sen Guo and Xing-Zhong Zhao

Department of Physics, Wuhan University, Wuhan 430072, China

(Received 22 December 2006; accepted 9 February 2007; published online 12 March 2007)

Piezoelectric materials can convert ambient vibrations into electrical energy. In this letter, the capability of harvesting the electrical energy from mechanical vibrations in a dynamic environment through a piezoelectric drum transducer has been investigated. Under a prestress of 0.15 N and a cyclic stress of 0.7 N, a power of 11 mW was generated at the resonance frequency of the transducer (590 Hz) across an 18 k Ω resistor. It is found that the energy from the transducer increases while the resonance frequency of the transducer decreases when the prestress increases. The results demonstrate the potential of the drum transducer in energy harvesting. © 2007 American Institute of Physics. [DOI: 10.1063/1.2713357]

With the recent advances in wireless and microelectro-mechanical systems technology, the demand for portable electronics and wireless sensors is growing rapidly. Since these devices are portable, it becomes necessary to carry their own power supply. Piezoelectric materials are ideal sources of such energy because they can convert mechanical strain energy into electrical energy or vice versa. Energy can be reclaimed and stored for later use to recharge a battery or power a device through a process called energy harvesting. Many researchers have studied the concept of utilizing piezoelectric material for energy generation over the past few decades.¹⁻⁵ In one prototype of power harvesting system, a polyvinylidene fluoride film was used and implemented *in vivo* on a mongrel dog. The feasibility of extracting energy from the expansion and contraction of the rib cage during breathing was explored in 1984.⁶ The power harvesting system produces a peak voltage of 18 V, which corresponded to a power of about 17 μ W. Another investigation for power harvesting from ambulation to provide supplemental power to operate artificial organs by using lead zirconate titanate (PZT)-based piezoelectric stacks during walking or jogging was performed by Antaki *et al.* in 1995.⁷ An average power of 250–700 mW was extracted from walking, and over 2 W was obtained from jogging. The recent progress in power harvesting from mechanical vibration to power generation was performed at Pennsylvania State University.⁸⁻¹⁰ These studies were made on a cymbal transducer having a ceramic disc with a diameter of 29 mm and 1 mm thickness. A power of 39 mW can be transferred across the low impedance load under a dynamic force of 7.8 N at 100 Hz. The effective piezoelectric field constant of the material is a crucial parameter for selecting an element of the piezoelectric energy harvesting device, which is proportional to the harvested power. In this letter, a drum transducer was studied as the energy

harvesting device because it was reported previously that the drum transducer has good electrical and mechanical performance.¹¹ It is expected that the energy harvesting performance of the drum transducer can be better than that of the cymbal transducer. The electrical power generation from a single drum transducer element under a cyclic force of 0.7 N with different prestressed conditions was investigated. The electrical power generated was transferred across a simple resistive load attached to the piezoelectric transducer.

Figure 1 shows the schematic diagram of the drum transducer consisting of a steel ring sandwiched between two thin ceramic-metal composite disks, which were fabricated by bonding a piezoceramic disk on a brass thin plate, serving as the driving units of the drum transducer.¹¹ Figure 2 shows the photograph and schematic diagram of the drum transducer. The brass plates of the composite disks were bonded on the steel ring using epoxy (Emerson & Cumming), and then cured at 60 °C for several hours. One of the electrical connections was made on the brass plate and the other electrical connection was on the piezoelectric disk. The polarity of both top and bottom piezoelectric ceramic disks is the same, which is along the thickness direction (in Fig. 2). As reported in previous investigations,¹¹ the inner diameter and the thickness of the steel ring are important design parameters for enhancing the performance of the transducer. As shown in Fig. 2, the diameter of the drum actuator is 20 mm, the inner diameter of the steel ring is 18 mm, the thickness of both the

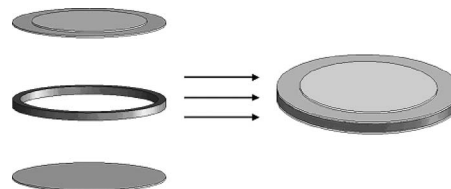

FIG. 1. Schematic diagram of a piezoelectric drum transducer.

^{a)}Electronic mail: apwangsh@polyu.edu.hk

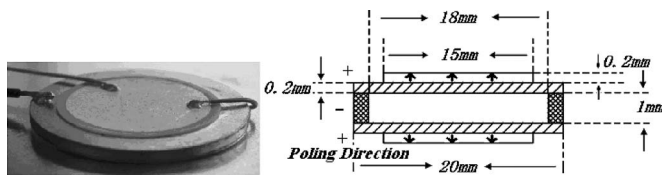

FIG. 2. Photo (left) and the schematic diagram (right) of the drum transducer.

ceramic and brass plate is 0.2 mm, and the thickness of the steel ring is 1 mm. The piezoelectric disk with a diameter of 15 mm was fabricated using PZT 502. Figure 3 shows the impedance plots of the drum transducer under free and different prestress conditions (by adding different loads on top of the transducer). It can be seen that the fundamental resonance mode of the transducer was about 6 kHz without any prestressing. When comparing the impedance plots of different prestressed conditions, the resonance frequency of the drum transducer was shifted to lower frequency as the prestress increases.

The experimental setup is shown in Fig. 4.¹² The mechanical shaker (Brüel & Kjær Instruments, model type V406) was used for measuring the response of the drum transducer under dynamic conditions. The shaker can apply a maximum of 89 N force within a wide frequency range of 5–9000 Hz. The prestress was provided by the mass weight. The mass weight was bonded on the transducer using epoxy before the measurement. The shaker was driven at various driving voltages and frequencies by using an arbitrary function generator (AFG 310) and an amplifier (Brüel & Kjær, model type PA 100E) to produce a cyclic force of the desired magnitude and frequency. The output voltage from the transducer was monitored by a Tektronix digital oscilloscope (TDS 210). In order to avoid any interference caused by the noise from the surroundings, all the experiments were performed on a spongy cushion.

The schematic diagram of the electronic circuit and photograph of the physical circuit are shown in Fig. 5. The equivalent circuit of the drum transducer is modeled as a current source in parallel with its capacitance C_p . The rectifier and a capacitor were used for storing the generated electrical energy of the drum transducer. The piezoelectric transducer charges up the large energy storage capacitor through a full wave rectifier bridge. The functions of different parts in the electronic circuit are described as follows. The full wave rectifying bridge circuit consists of the four small signal Schottky diodes (ST Microelectronics 1N5711). These diodes

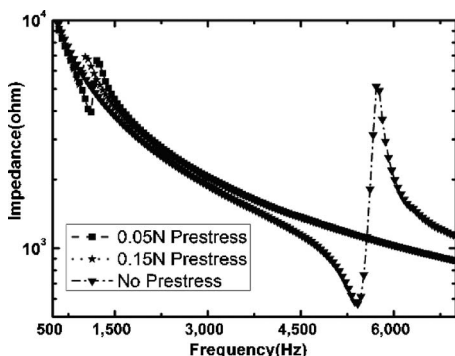

FIG. 3. Impedance plots of the drum transducer under free and different prestressed conditions.

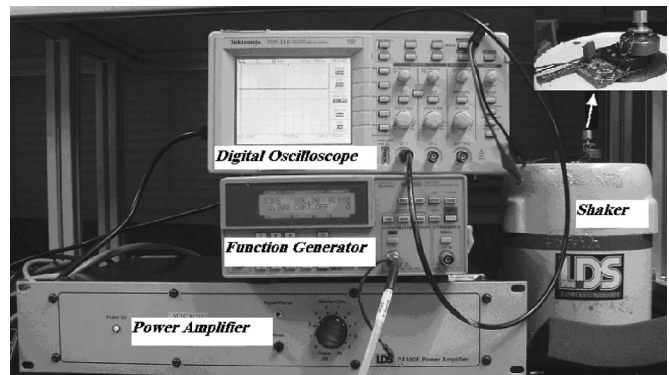

FIG. 4. Experimental setup of energy harvesting with a drum transducer.

were chosen because, compared to most discrete components, they have the smallest forward voltage drop (approximately 0.2 V). This allows for the largest possible dc voltage to develop across the capacitor/load. The storage capacitor is a 10 μ F tantalum capacitor (NEC) with a very low leakage current (approximately 20 μ A). The performance including the output voltage and the output power of the transducer were initially characterized with the circuit directly across the resistive loads without any amplification. When the impedance of the load resistor, R_{load} , is matched to the equivalent impedance of the drum transducer, the energy harvested would be the maximum.

Figure 6 shows the results of the drum transducer as a function of the frequency with various resistive loads. The results were measured as a function of load resistance with a fixed prestress condition (0.05 N) under a cyclic stress of 0.7 N. A maximal output power of about 3 mW can be obtained from the transducer at the operating frequency of 980 Hz across a resistive load of 18 k Ω . It was shown that

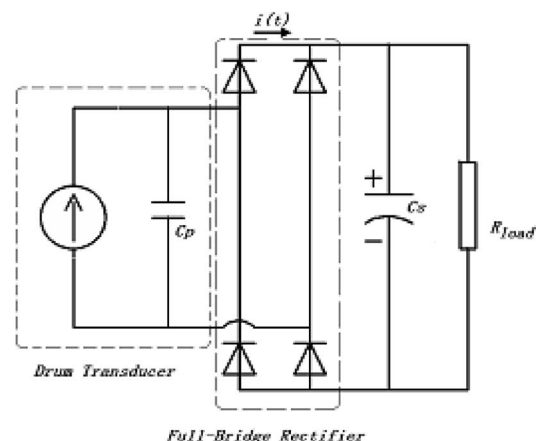
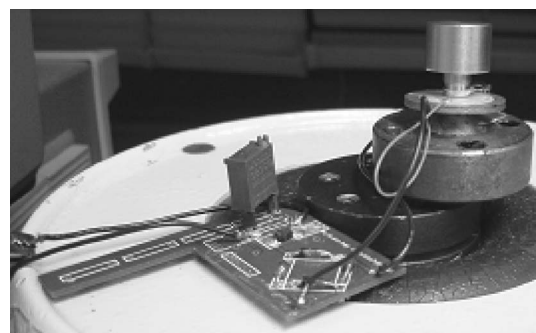

FIG. 5. Schematic diagram of the energy harvesting circuit.

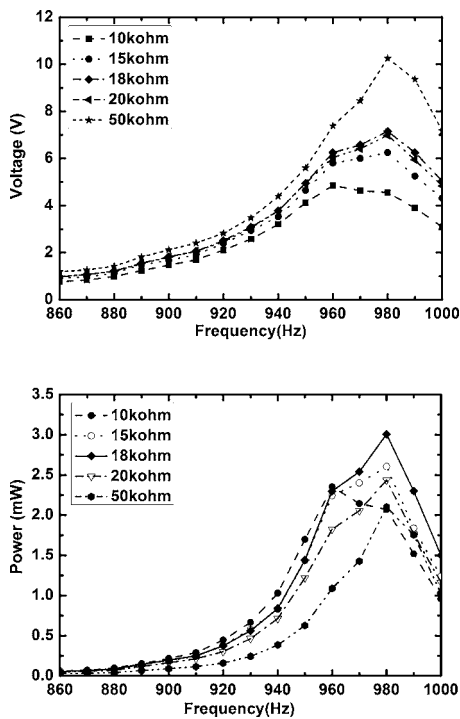

FIG. 6. Output voltage and power of a drum transducer as a function of frequency with various resistive load after rectification under a cyclic stress of 0.7 N and a prestress of 0.05 N.

the output voltage of the transducer increases with the resistive load. The voltage approaches 7 V when the resistive load is 18 k Ω . Nevertheless, the electrical power decreases when the load resistance is further increased.

As shown in Fig. 3, the resonance frequency of the transducer is shifted to lower frequency as the prestress increases. It is expected that the output voltage and power of the transducer vary with different prestressed conditions. However, the prestress cannot be increased indefinitely because of the mechanical limitation of the transducer. When the prestress is increased, the output power of the transducer increases at lower resonance frequency, as shown in Fig. 7. A maximal output power of ~ 11 mW can be obtained from the transducer at 590 Hz across a resistive load of 50 k Ω . A 14 V dc voltage was measured at the 11 mW power level. As a result, a power of 11 mW can be harvested at 590 Hz across the resistive load of 18 k Ω while the voltage of 14 V can be generated under the same condition. In this study, the dynamic force applied to the transducer was around 0.7 N. Comparing the results in Figs. 6 and 7, the output voltage and the output power of the transducer are increased as the prestress increases, and the frequency of the maximal output signal is shifted to a lower frequency.

The characteristics of energy storage by a piezoelectric drum transducer with a full wave rectifier bridge and a capacitor have been investigated. A preload of 0.7 N at 590 Hz applied on the drum transducer with a dimension of $\phi 20 \times 1.0$ mm² resulted in an electrical power generation of 11 mW across an 18 k Ω resistor. The experimental results show that the energy from the drum transducer can be in-

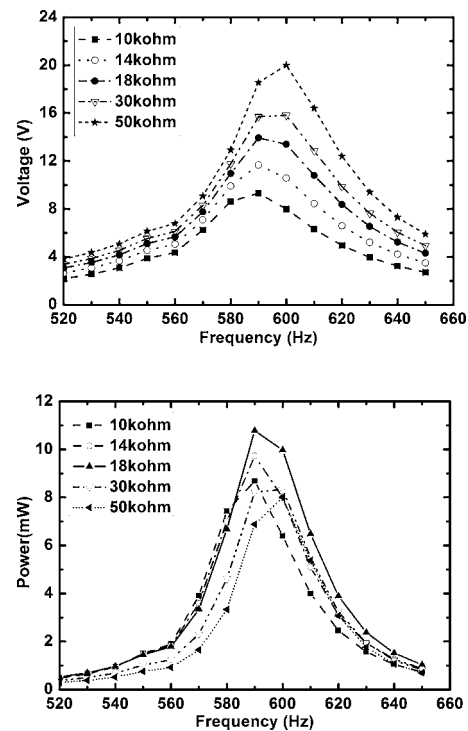

FIG. 7. Output voltage and power of a drum transducer as a function of frequency with various resistive loads after rectification under a cyclic stress of 0.7 N and a prestress of 0.15 N.

creased along with the prestress, and the resonance frequency would be lowered with increasing prestress. Based on this study, it can be seen that the drum transducer has the potential to be an energy harvesting device to provide enough power for portable electronics and wireless sensors. This small device can be used for low-power applications such as powering up a small infrared detector.

This work was supported by the Guangdong-Hong Kong Technology Cooperation Funding Scheme under the Innovation and Technology Fund of the Hong Kong SAR Government (GHS/066/04) and by the Centre for Smart Materials of the Hong Kong Polytechnic University.

- ¹H. A. Sodano, D. J. Inman, and G. Park, *J. Intell. Mater. Syst. Struct.* **16**, 799 (2005).
- ²N. E. Dutoit, B. L. Wardle, and S. G. Kim, *Integr. Ferroelectr.* **71**, 121 (2005).
- ³H. A. Sodano, D. J. Inman, and G. Park, *Shock Vib. Dig.* **36**, 197 (2004).
- ⁴S. Roundy and P. Kwright, *Smart Mater. Struct.* **13**, 1131 (2004).
- ⁵G. A. Lesieutre, G. K. Ottman, and H. F. Hofmann, *J. Sound Vib.* **269**, 991 (2004).
- ⁶E. Hausler and E. Stein, *Ferroelectrics* **60**, 277 (1984).
- ⁷J. Antaki, G. Bertocci, E. Green, A. Nadeem, T. Rintoul, R. Kormos, and B. Griffith, *ASAIO J.* **41**, M588 (1995).
- ⁸H. W. Kim, S. Priya, and K. Uchino, *Jpn. J. Appl. Phys., Part 1* **45**, 5836 (2006).
- ⁹H. W. Kim, S. Priya, K. Uchino, and R. E. Newnham, *J. Electroceram.* **15**, 27 (2005).
- ¹⁰H. W. Kim, A. Batra, S. Priya, K. Uchino, D. Markley, R. E. Newnham, and H. F. Hofmann, *Jpn. J. Appl. Phys., Part 1* **43**, 6178 (2004).
- ¹¹C. L. Sun, K. H. Lam, H. L. W. Chan, X. Z. Zhao, and C. L. Choy, *Appl. Phys. A: Mater. Sci. Process.* **84**, 385 (2006).
- ¹²H. A. Sodano, G. Park, and D. J. Inman, *Strain*, **40**, 49 (2004).