



US007942018B2

(12) **United States Patent**
Niu et al.

(10) **Patent No.:** **US 7,942,018 B2**
(45) **Date of Patent:** **May 17, 2011**

(54) **APPARATUS FOR COOLING OR HEATING THERMAL STORAGE USING MICROENCAPSULATED PHASE CHANGE MATERIAL SLURRIES**

4,821,794 A * 4/1989 Tsai et al. 165/104.17
4,911,232 A 3/1990 Colvin et al.
5,007,478 A 4/1991 Sengupta
6,447,692 B1 9/2002 Momoda et al.
6,797,193 B2 9/2004 Brown et al.

(75) Inventors: **Jianlei Niu**, Hong Kong (HK); **Xichun Wang**, Hong Kong (HK)

(73) Assignee: **The Hong Kong Polytechnic University**, Hong Kong (CN)

(*) Notice: Subject to any disclaimer, the term of this patent is extended or adjusted under 35 U.S.C. 154(b) by 776 days.

(21) Appl. No.: **12/024,425**

(22) Filed: **Feb. 1, 2008**

(65) **Prior Publication Data**

US 2009/0194257 A1 Aug. 6, 2009

(51) **Int. Cl.**
F25D 17/02 (2006.01)

(52) **U.S. Cl.** **62/434**

(58) **Field of Classification Search** 62/59, 434;
165/104.17

See application file for complete search history.

(56) **References Cited**

U.S. PATENT DOCUMENTS

3,869,870 A * 3/1975 Kuehner 62/114
4,696,338 A * 9/1987 Jensen et al. 165/104.17

OTHER PUBLICATIONS

Wang, X. et al., "Flow and Heat Transfer Behaviors of Phase Change Material Slurries in a Horizontal Circular Tube", International Journal of Heat and Mass Transfer, 50, pp. 2480-2491, (2007).

Wang, X. et al., "Heat Transfer of Microencapsulated PCM Slurry Flow in a Circular Tube", AIChE Journal, vol. 54, No. 4, pp. 1110-1120, (2008).

* cited by examiner

Primary Examiner — Melvin Jones

(74) Attorney, Agent, or Firm — George G. Wang; Wilkinson & Grist

(57) **ABSTRACT**

A thermal storage system includes a thermal storage device that includes an aqueous slurry of micro-encapsulated phase change material, a thermal collector in a heat exchange relationship with the thermal storage device through a first heat exchanger, and a thermal service device in a heat exchange relationship with the thermal storage device through a second heat exchanger. The aqueous slurry of micro-encapsulated phase change material is configured to convert between solid and liquid states.

20 Claims, 4 Drawing Sheets

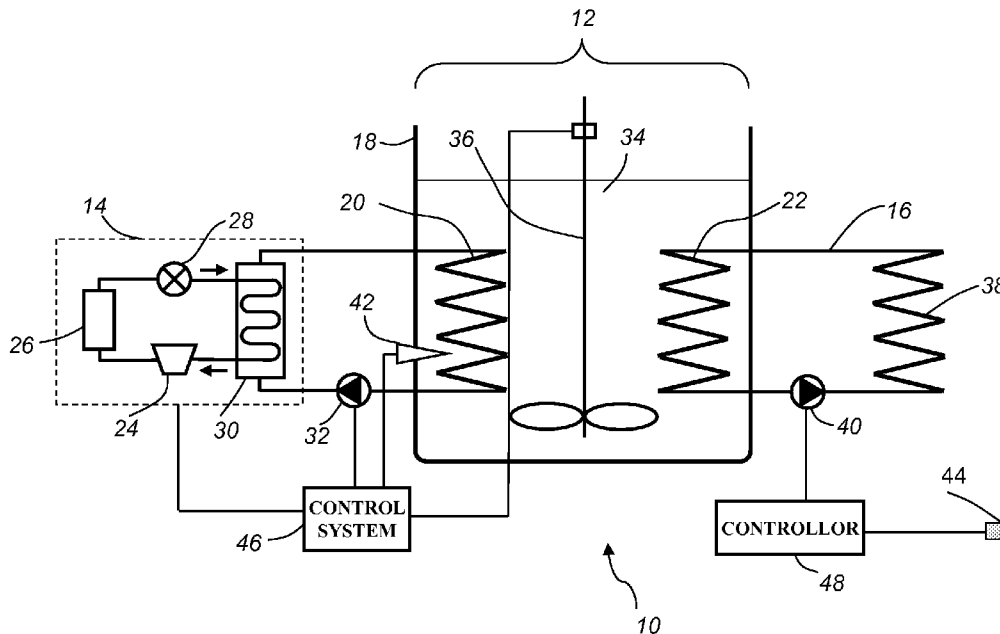

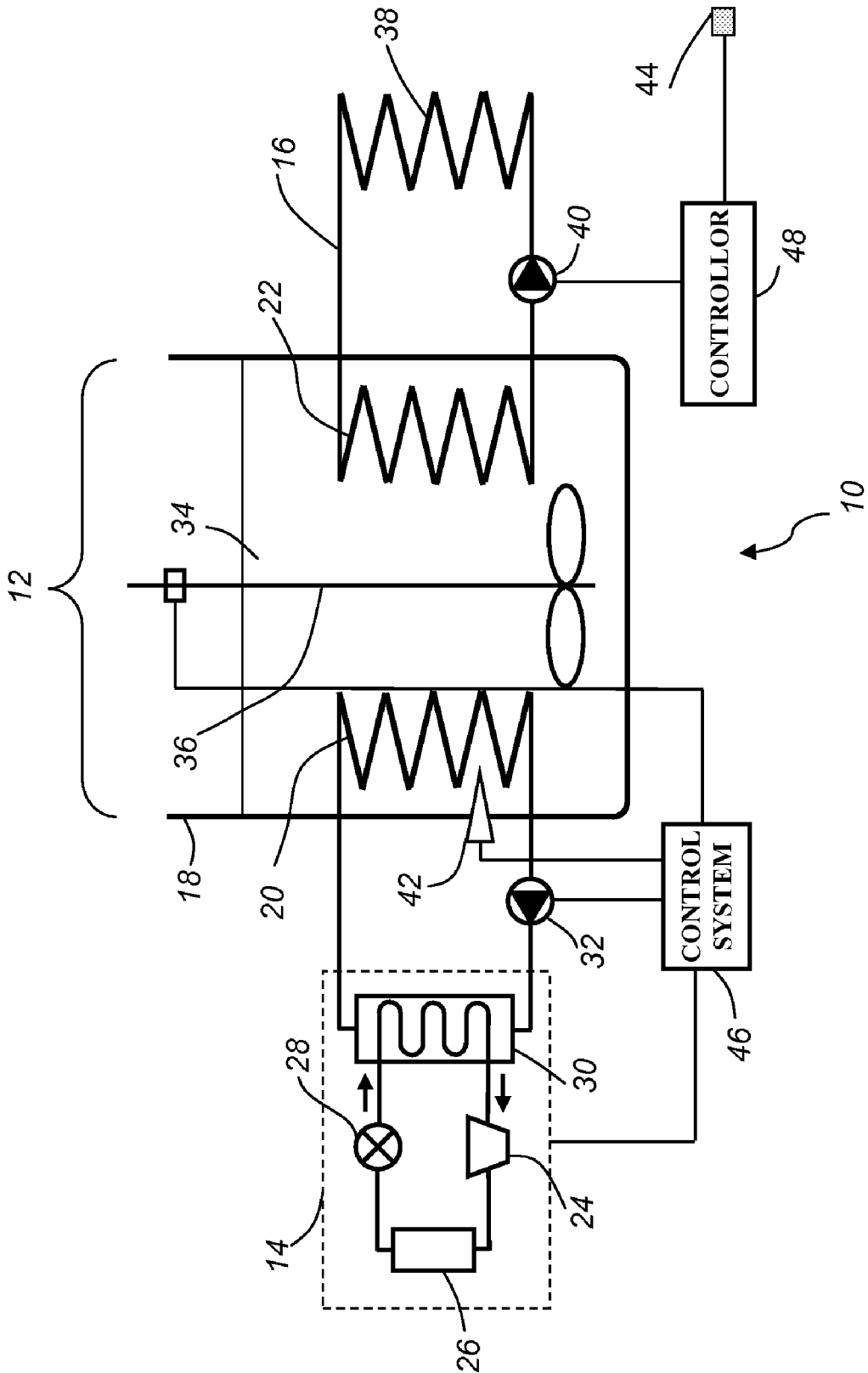

FIG. 1

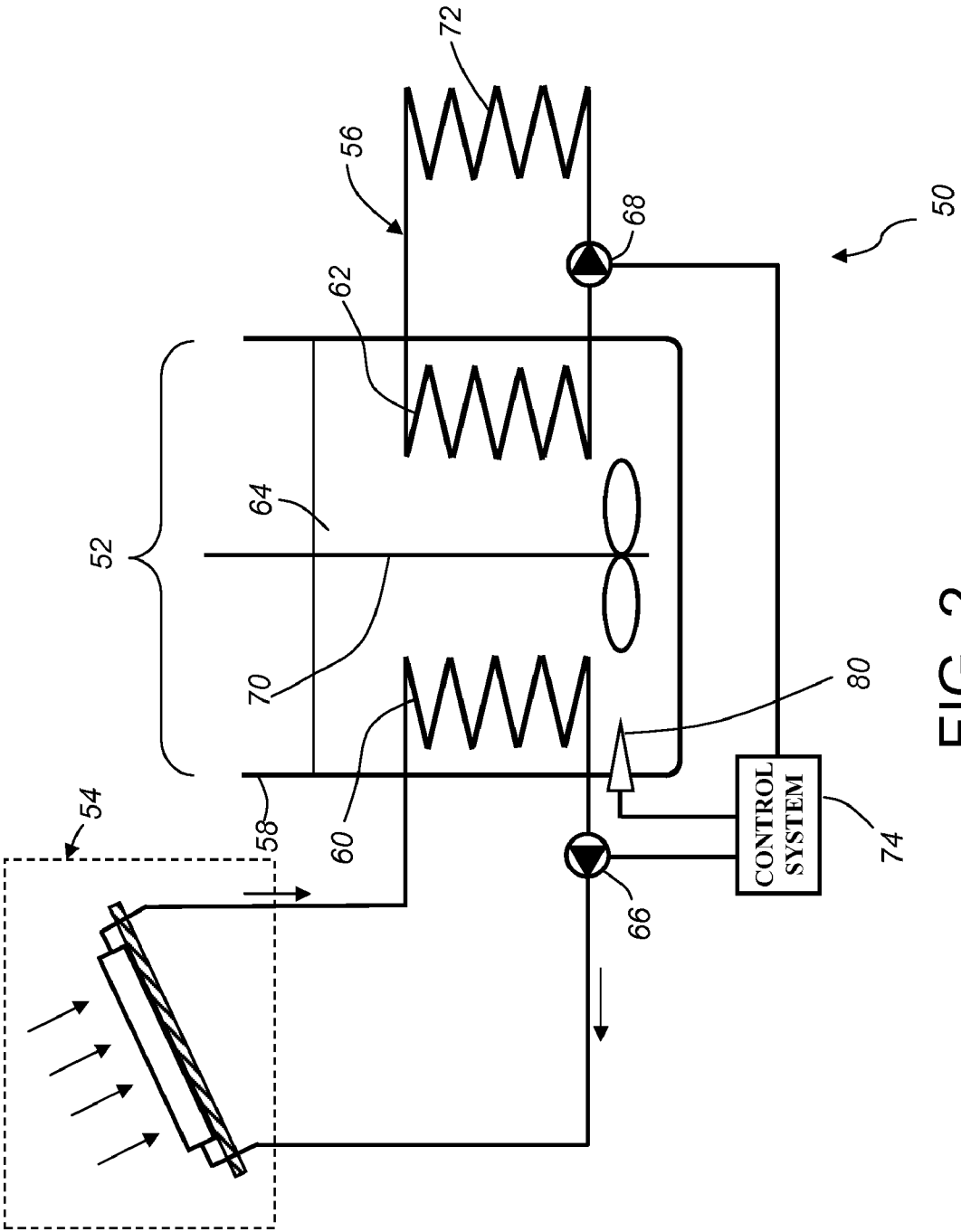

FIG. 2

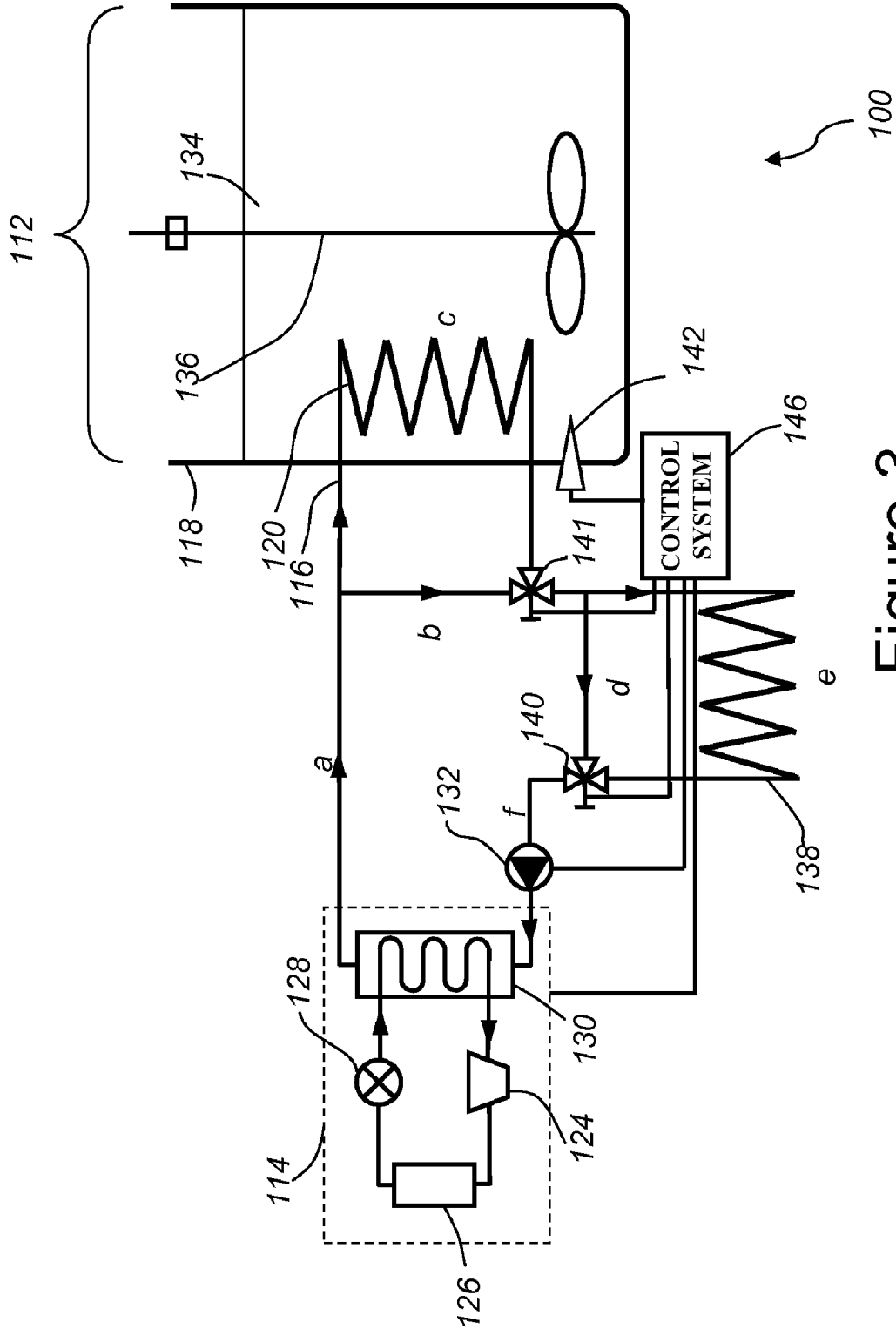

Figure 3

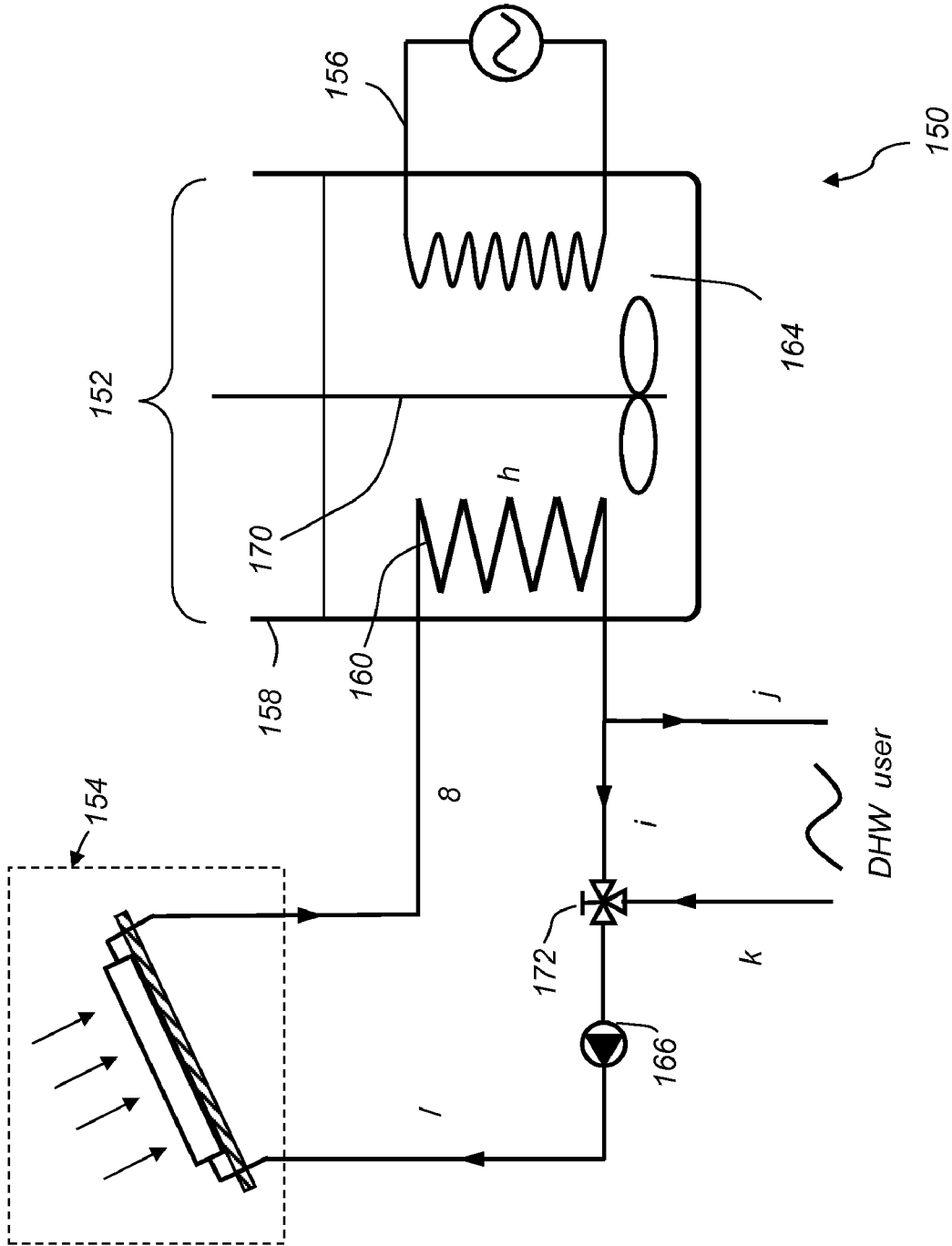

FIG. 4

1

**APPARATUS FOR COOLING OR HEATING
THERMAL STORAGE USING
MICROENCAPSULATED PHASE CHANGE
MATERIAL SLURRIES**

BACKGROUND

Thermal storage systems typically use inexpensive off-peak electric power, solar energy or waste heat to meet heating, cooling or hot water requirements. Ice and water have been the traditional storage media to store the thermal energy, but with inherent constraints. Ice storage is limited to the working temperature of around 0° C., which is too low for many applications such as air-conditioning, and is energy inefficient. Water, while convenient to harness, has limited heat storage capacity, as it relies on sensible heat in the temperature range of only 0 to 100° C., and the water storage tank is usually bulky.

Microencapsulated phase change materials (MPCM) offer the flexibility of a wide range of working temperatures when suspended in water to form an aqueous slurry in a thermal storage tank. Phase change materials contained within microcapsules may be frozen into solid states through refrigeration to effect cooling storage. MPCM contained within microcapsules may be melted into liquid state by solar energy or waste heat to effect heat storage. The phase change materials may be used to store thermal energy by cycling between solid and liquid phases. When a liquid material is solidified, heat is released, providing a heating effect, with the accompanying absorption and release of heat, which accomplish the heating or cooling effects.

Therefore, the thermal storage systems that incorporate MPCM may be used to store energy. This thermal storage can allow electricity usage to be shifted towards periods of the day with lower electricity costs. This redistribution of electricity usage can allow peak shaving, which may result in the reduction of the overall electricity capacity requirement. Such a system can also be used to store thermal energy available from natural evaporative cooling and solar heating.

However, MPCM slurries have been used in cooling applications only at low concentrations. One reason for this limitation is that the slurries present non-Newtonian behaviors when the particle volume fractions are higher than about 30 percent. A low MPCM particle concentration corresponds to lower heat storage capacity for a given volume of a storage tank. Moreover, the breakage of particles, which can result from the impact with the pump, may lead to higher pump energy consumption due to agglomeration of the material.

It is desirable to develop a new thermal storage system operating with an MPCM slurry having a particle concentration higher than 30 percent. It is also desirable that such a system has minimal breakage of the MPCM during its performance life.

BRIEF SUMMARY

According to one aspect, a thermal storage system includes a thermal storage device that includes an aqueous slurry of micro-encapsulated phase change material, a thermal collector in a heat exchange relationship with the thermal storage device through a first heat exchanger, and a thermal service device in a heat exchange relationship with the thermal storage device through a second heat exchanger. The aqueous slurry of micro-encapsulated phase change material is configured to convert between solid and liquid states.

According to another aspect, a thermal storage system includes a thermal storage device that includes an aqueous

2

slurry of micro-encapsulated phase change material, a thermal collector in a heat exchange relationship with the thermal storage device through a single heat exchanger, and a thermal service device connect to the heat exchanger and the thermal storage device. The aqueous slurry of micro-encapsulated phase change material is configured to convert between solid and liquid states.

BRIEF DESCRIPTION OF THE DRAWINGS

FIG. 1 depicts a thermal storage system having cold storage capability.

FIG. 2 depicts a thermal storage system having heat storage capability.

FIG. 3 depicts a thermal storage system having cold storage capability with a single heat exchanger.

FIG. 4 depicts a thermal storage system having heat storage capability with a single heat exchanger and auxiliary electric heating.

DETAILED DESCRIPTION

Reference will now be made in detail to a particular embodiment of the invention, examples of which are also provided in the following description. Exemplary embodiments of the invention are described in detail, although it will be apparent to those skilled in the relevant art that some features that are not particularly important to an understanding of the invention may not be shown for the sake of clarity.

Furthermore, it should be understood that the invention is not limited to the precise embodiments described below, and that various changes and modifications thereof may be effected by one skilled in the art without departing from the spirit or scope of the invention. For example, elements and/or features of different illustrative embodiments may be combined with each other and/or substituted for each other within the scope of this disclosure and appended claims. In addition, improvements and modifications which may become apparent to persons of ordinary skill in the art after reading this disclosure, the drawings, and the appended claims are deemed within the spirit and scope of the present invention.

Thermal Storage Apparatus

A thermal storage system may include a thermal storage device, a thermal collector in a heat exchange relationship with the thermal storage device, and a thermal service device in a heat exchange relationship with the thermal storage device. In a cold storage system, cold energy may be collected from a refrigerator 14, stored in the cold storage device 12, and delivered to the cold service device 16 for use, as depicted in FIG. 1. In a heat storage system, heat energy may be collected from a solar heat collector 54, stored in the heat storage device 52, and delivered to the heat service device 56 for use, as depicted in FIG. 2.

In one embodiment, a cold storage system 10 may include a cold storage device 12, a refrigerator 14 in heat exchange relationship with the cold storage device 12 through a first heat exchanger 20, and a cold service device 16 in a heat exchange relationship with the cold storage device 12 through a second heat exchanger 22, as depicted in FIG. 1. The refrigerator 14 may include a compressor 24, a condenser 26, an expansion valve 28, and an evaporator 30. The cold service device 16 may include a cooling load 38. Examples of a cooling load 38 may include sensible cooling load of the cooled ceiling panels served for an occupied space and cooled load of the coil to cool the air.

The cold storage device 12 may include a vessel 18, where MPCM slurry 34 may be contained within the vessel 18 and

used as the cold storage medium. The cold storage device **12** may also include the first heat exchanger **20**, which may be immersed in the slurry **34** of the vessel **18**, in a heat exchange relationship between the refrigerator **14** and the slurry **34**. The cold storage device **12** may further include the second heat exchanger **22**, which may also be immersed in the slurry **34** of the vessel **18**, in a heat exchange relationship between the cold service device **16** and the slurry **34**. Optionally, the first heat exchanger **20** and the second heat exchanger **22** may be combined into a single heat exchanger, such as a heat exchanger having a size smaller than that of the first **20** and second **22** heat exchangers combined.

The first heat exchanger **20** may include a first circulating pump **32**, which may be used to circulate a first heat transfer medium that may circulate between the evaporator **30** of the refrigerator **14** and the slurry **34**. For example, the first heat transfer medium may include a refrigerant and a glycol solution. Other examples may include water. Therefore, the first heat exchanger **20** may be used to remove heat from the slurry **34**, effectively storing cold energy in the slurry.

The term "cold energy" means the potential to absorb heat. A substance that has cold energy can remove heat energy from another substance, causing a phase change and/or a lowering of the temperature of the other substance.

The term "heat energy" means the potential to release heat. A substance that has heat energy can release heat energy to another substance, causing a phase change and/or a rising of the temperature of the other substance.

The second heat exchanger **22** may include a second circulating pump **40**, which may be used to circulate a second heat transfer medium that may circulate between the slurry **34** and the cooling load **38** of the cold service device **16**. For example, the second heat transfer medium may include a glycol solution. Other examples may include water. The second heat exchanger **22** may be used to discharge the cold energy from the slurry **34** to an end user.

The vessel **18** with heat exchangers **20** and **22** immersed in the slurry **34** may provide indirect charging or discharging of cold energy. Since the MPCM particles are not circulated through a pump, such as **32** or **40**, the breakage of the particles can be avoided.

The vessel **18** may be equipped with an agitator **36**, such as a variable speed agitator. Agitation of slurry **34** may help to ensure the slurry is homogeneous and ideally mixed. In addition, agitation can increase the rate of heat transfer rate between the slurry **34** and the heat exchangers **20** and **22**. The heat transfer rate of the heat exchanges **20** and **22** to charge or discharge the heat energy or cold energy in the MPCM particles may be controlled by adjusting the speed of the agitator **36**.

The refrigerator **14** and the first circulating pump **32** may be modulated by a control system **46**, based upon a temperature detected by a first temperature sensor **42**. For example, during a nighttime period, such as from 22:00 to 6:00, the control system **46** may switch on the refrigerator **14**. In this example, when the slurry temperature detected by the temperature sensor **42** is lower than the solidification temperature of the phase change material, the control system **46** may switch off the refrigerator **14**.

The second circulating pump **40** may be modulated by a controller **48** connected to a second temperature sensor **44**, which can measure a temperature of interest to the user of the device. For example, the second temperature sensor **44** may measure an ambient temperature of a room, an off-coil supply temperature, or another temperature related to the equipment of a room.

MPCM Slurry

The MPCM slurry is configured to remain in the storage device **12**, rather than being pumped through pipelines. One advantage of this configuration is that the high heat storage capacity available at higher concentrations of MPCM particles may be achieved without increasing the system pump energy. Another advantage is that the breakage of PCM micro-capsules may be minimized, resulting in longer service life of the system **10**, and the ability to recycle the PCM microcapsules.

The MPCM slurry **34** includes phase change particles that are microencapsulated by a thin plastic outer coating. The core material can convert between solid and liquid states. The outer coating has a higher melting temperature and is durable so as to endure thousands of thermal cycles without breakage.

Compared to conventional single-phase heat transfer fluid, phase change slurries offer several advantages. An MPCM slurry may provide for absorption or release of high-density thermal energy from the absorbing or releasing of latent heat during the phase change of MPCM particles. The slurries also may have relatively low variations in operating temperatures, due to the approximately constant temperature during the charging or discharging processes of MPCM. This may offer incentives to use low-grade thermal energies. In addition, the slurries may provide a high heat transfer rate around the particles, due to the large surface area to volume ratio.

In an example, the PCM materials includes a paraffin, which can be made into micro-capsules using micro-encapsulation technology. Examples include tetradecane with a melting temperature (T_m) of 5.5° C., 1-bromohexadecane ($C_{16}H_{33}Br$) with a T_m of 14.3° C., and hexadecane with a T_m of 16.7° C. The large latent heat of fusion of the paraffin type MPCM slurry may also be used to increase the heat transfer capacity due to the large surface area to volume of the MPCM particles in fluid. Slurries containing these particles may result in a compact energy storage system.

The particle concentration of the slurry used for this system **10** may be increased to up to 30 percent, since no pumping through the pipelines is required. In conventional systems the increased viscosity at this high concentration would cause undesirably high pump energy consumption. For example, the dynamic viscosity of a slurry with 20% particle mass concentration is 20.4 mPa·s at 20° C., while the viscosity of slurry with 30% concentration is 41.9 mPa·s at the same temperature.

Operation

During an operation mode of cold storage, cold energy may be first generated from the refrigerator **14**. By circulating the first heat transfer medium, the cold energy may be collected from the refrigerator **14** and transferred to the MPCM slurry **34** through the first heat exchanger **20**. The cold energy transferred from the refrigerator **14** may convert the liquid cores of the MPCM particles into solid cores, storing cold energy in the MPCM slurry **34** as latent energy of fusion. Therefore, the system **10** may be used to store cold energy during a non-peak-electricity period where energy cost would be lowest.

To dispatch the cold energy to an end user, the second heat transfer medium may be circulated, delivering heat to the slurry. The corresponding of the MPCM particles may then change from solid to liquid, discharging the cold energy as latent energy of fusion to the cooling load **38** of the cold service device **16** through the second heat exchanger **22**. Therefore, the system **10** may be used to deliver sensible heat at a peak-electricity period where energy cost would otherwise be highest.

Heat Storage

In a second embodiment, a heat storage system **50** may include a heat storage device **52**, a solar heat collector **54** in a heat exchange relationship with the heat storage device **52**, and a heat service device **56** in a heat exchange relationship with the heat storage device **52**, as depicted in FIG. 2. The solar heat collector **54** may be any commercially available collector. The heat service device **56** may include a heating load **72**. Examples of a heating load **72** may include a domestic heater or a hot water heater.

The heat storage device **52** may include a vessel **58**, where an MPCM slurry **64** may be contained within the vessel **58** and used as the heat storage medium. The heat storage device **52** also may include a first heat exchanger **60**, which may be immersed in the slurry **64** of the vessel **58**, in a heat exchange relationship between the solar heat collector **54** and the slurry **64**. The heat storage device **52** may further include a second heat exchanger **62**, which may also be immersed in the slurry **64** of the vessel **58**, in a heat exchange relationship between the heat service device **56** and the slurry **64**. Optionally, the first heat exchanger **60** and the second heat exchanger **62** may be combined into a single heat exchanger, such as a heat exchanger having a size smaller than that of the first **60** and second **62** heat exchangers combined.

The first heat exchanger **60** may include a first circulating pump **66**, which may be used to circulate a third heat transfer medium that may circulate between the solar heat collector **54** and the slurry **64**. For example, the third heat transfer medium may include glycol solution. Other examples may include water. Therefore, the first heat exchanger **60** may be used to charge the heat energy to the slurry **64**, effectively storing heat energy in the slurry.

The second heat exchanger **62** may include a second circulating pump **68**, which may be used to circulate a fourth heat transfer medium that may circulate between the slurry **64** and the heating load **72** of the heat service device **56**. For example, the fourth heat transfer medium may include glycol solution. Other examples may include water. The second heat exchanger **62** may be used to discharge the heat energy from the slurry **64** to an end user.

The vessel **58** with heat exchangers **60** and **62** immersed in the slurry **64** may provide indirect charging or discharging of heat energy. Since the MPCM particles are not circulated through a pump, such as **66** or **68**, the breakage of the particles can be avoided.

The vessel **58** may be equipped with an agitator **70**, such as a variable speed agitator. Agitation of slurry **64** may help to ensure the slurry is homogeneous and ideally mixed. In addition, agitation can increase the rate of heat transfer rate between the slurry **64** and the heat exchangers **60** and **62**. The heat transfer rate of the heat exchanges **60** and **62** to charge or discharge the heat energy or cold energy in the MPCM particles may be controlled by adjusting the speed of the agitator **70**.

The first circulating pump **66** and the second circulating pump **68** may be modulated by a control system **74**, based on a temperature detected by a third temperature sensor **80**. For example, during a daytime period, the control system **74** may switch on the first circulating pump **66**, and the heat collected from the solar collector **54** will be stored in the vessel **58**. During the heat release period, the control system **74** may switch on the pump **68**, and the heat is transferred to heating load **72** by the heat exchanger **62**.

MPCM Slurry

The MPCM slurry is configured to remain in the storage device **50**, rather than being pumped through the pipelines. In an example, the PCM materials includes a paraffin, which can

be made into micro-capsules using micro-encapsulation technology. Examples include Heneicosane ($T_m=40.2^\circ\text{C}$.), Docosane ($T_m=44^\circ\text{C}$.) and Trocosane ($T_m=47.5^\circ\text{C}$.).

Operation

During an operation mode of heat storage, heat energy may be first collected from the solar heat collector **54**. By circulating the third heat transfer medium, the heat energy may be collected from the solar heat collector **54** and transferred to the MPCM slurry **64** through the first heat exchanger **60**. The heat energy transferred from the heat collector **54** may convert the solid cores of the MPCM particles into liquid cores, storing heat energy in the MPCM slurry **64** as latent energy of fusion. Therefore, the system **50** may be used to store heat energy during a non-peak-electricity period where energy cost would be lowest.

To dispatch the heat energy to an end user, the fourth heat transfer medium may be circulated, absorbing heat from the slurry. The cores of the MPCM particles may then change from liquid to solid, discharging the heat energy as latent energy of fusion to the cooling load **72** of the heat service device **56** through the second heat exchanger **62**. Therefore, the system **50** may be used to deliver sensible heat at a peak-electricity period where energy cost would otherwise be highest.

Thermal Storage System with One Heat Exchanger

In a third embodiment, a cold storage system **100** may include a cold storage device **112**, a refrigerator **114** and a cooling load **138**. The refrigerator **114** and the cooling load **138** are in a heat exchange relationship with the cold storage device **112** through a single heat exchanger **120**, as depicted in FIG. 3.

The refrigerator **114** may include a compressor **124**, a condenser **126**, an expansion valve **128**, and an evaporator **130**. Examples of a cooling load **138** may include sensible cooling load of the cooled ceiling panels served for an occupied space and cooled load of the coil to cool the air.

The cold storage device **112** may include a vessel **118**, where an MPCM slurry **134** may be contained within the vessel **118** and used as the cold storage medium. The cold storage device **112** may also include the heat exchanger **120**, which may be immersed in the slurry **134** of the vessel **118**. The heat exchanger **120** may have a size smaller than two separate exchangers. This may leave more space for the slurry **134** in the vessel **118**, and therefore reduce the required vessel size.

The heat exchanger **120** may include a circulating pump **132**, which may be used to circulate the first heat transfer medium that may circulate between the evaporator **130** of the refrigerator **114** and the slurry **134**. For example, the first heat transfer medium may include a refrigerant and a glycol solution. Other examples may include water. Therefore, the first heat exchanger **120** may be used to remove heat from the slurry **134**, effectively storing cold energy in the slurry.

The vessel **118** with heat exchanger **120** immersed in the slurry **134** may provide indirect charging or discharging of cold energy. Since the MPCM particles are not circulated through a pump, such as **132**, the breakage of the particles can be avoided.

The vessel **118** may be equipped with an agitator **136**, such as a variable speed agitator. Agitation of slurry **134** may help to ensure the slurry is homogeneous and ideally mixed. In addition, agitation can increase the rate of heat transfer rate between the slurry and the heat exchangers. The heat transfer rate of the heat exchange **120** to charge or discharge the heat energy or cold energy in the MPCM particles may be controlled by adjusting the speed of the agitator **136**.

The refrigerator **114**, the circulating pump **132**, two three-way control valves **140** and **141**, and a pipe system a to f may be modulated by a control system **146**, based upon the temperature detected by a temperature sensor **142**. In this example, during a nighttime period, such as from 22:00 to 6:00, the control system **146** may switch on the refrigerator **114**, and when the slurry temperature detected by the temperature sensor **142** is lower than the solidification temperature of the phase change material, the control system **146** may switch off the refrigerator **114**.

The MPCM slurry is configured to remain in the storage device **112**, rather being pumped through the pipelines. In an example, the PCM materials includes a paraffin, which can be made into micro-capsules using micro-encapsulation technology. Examples include tetradecane with a melting temperature (T_m) of 5.5° C., 1-bromohexadecane ($C_{16}H_{33}Br$) with a T_m of 14.3° C., and hexadecane with a T_m of 16.7° C.

Operation

During an operation mode of cold storage, cold energy may be first collected from the refrigerator **114**. By circulating the heat transfer medium, the cold energy may be collected from the refrigerator **114** and transferred to the MPCM slurry **134** through the heat exchanger **120** in the path a-c-d-e and by modulating the three-way control valves **140** and **141**. The cold energy transferred from the refrigerator **114** may convert the liquid cores of the MPCM particles into solid cores, storing cold energy in the MPCM slurry **134** as latent energy of fusion. Therefore, the system **100** may be used to store latent cold energy during a non-peak-electricity period where energy cost would be lowest.

To dispatch the cold energy to an end user, the heat transfer medium may flow in the path a-c-e-f to transfer the cold energy in the vessel **118** through the heat exchanger **120** by controlling the three-way control valves **140** and **141**. Then the cold energy may be released to the cooling load **138** by transferring the cold energy in cold service device **116**.

When the cold energy stored in the vessel **118** is not sufficient to service the cooling load **138**, the refrigerator **114** may then be switched on and the heat transfer medium may flow in the path a-b-e-f by controlling the three-way control valve **140** and **141**. Thus, the refrigerator **114** may directly supply the cooling load **138** in this operation mode.

Solar Water Heater

In the fourth embodiment, a heat storage system **150** for hot water generation may include a heat storage device **152**, a solar heat collector **154** in a heat exchange relationship with the heat storage device **152**, and a heat service device **156** in a heat exchange relationship with the heat storage device **152**, as depicted in FIG. 4. The solar heat collector **154** may be any commercially available collector.

The heat storage device **152** may include a vessel **158**, where an MPCM slurry **164** may be contained within the vessel **158** and used as the heat storage medium. The heat storage device **152** also may include a single heat exchanger **160**, which may be immersed in the slurry **164** of the vessel **158**, in a heat exchange relationship between the solar heat collector **154** and the slurry **164**. The heat storage device **152** may further include the heat service device **156**, such as an auxiliary electricity heating system, which may also be immersed in the slurry **164** of the vessel **158**, in a heat exchange relationship between the heat service device **156** and the slurry **164**. The auxiliary electricity heating system is configured to provide additional heat generation to the vessel **158**.

The heat exchanger **160** may include a circulating pump **166**, which may be used to circulate a heat transfer medium that may circulate between the solar heat collector **154** and the

slurry **164** through a three-way control valve **172** and a pipe system g to l. For example, the heat transfer medium may include glycol solution. Other examples may include water. Therefore, the heat exchanger **160** may be used to charge the heat energy to the slurry **164**, effectively storing heat energy in the slurry.

The vessel **158** with heat exchanger **160** immersed into the slurry **164** may provide indirect charging or discharging of heat energy. Since the MPCM particles are not circulated through a pump, such as **66** or **68**, the breakage of the particles can be avoided.

The vessel **158** may be equipped with an agitator **170**, such as a variable speed agitator. Agitation of slurry **164** may help to ensure the slurry is homogeneous and ideally mixed. In addition, agitation can increase the rate of heat transfer rate between the slurry and the heat exchangers. The heat transfer rate of the heat exchange **160** to charge or discharge the heat energy or cold energy in the MPCM particles may be controlled by adjusting the speed of the agitator **170**.

MPCM Slurry

The MPCM slurry is configured to remain in the storage device **150**, rather than being pumped through the pipelines. In an example, the PCM materials includes a paraffin, which can be made into micro-capsules using micro-encapsulation technology. Examples include Heneicosane ($T_m=40.2^\circ\text{C}$.), Docosane ($T_m=44^\circ\text{C}$.) and Tocosane ($T_m=47.5^\circ\text{C}$.).

Operation

During an operation mode of heat storage, heat energy may be first collected from the solar heat collector **154**. By circulating the heat transfer medium, the heat energy may be collected from the solar heat collector **154** and transferred to the MPCM slurry **164** through the heat exchanger **160** in the path g-h-i-l and by modulating the three-way control valve **172**. The heat energy transferred from the solar heat collector **154** may convert the solid cores of the MPCM particles into liquid cores and stored in the MPCM slurry **164** as latent energy of fusion.

To dispatch the heat energy to an end user, the heat transfer medium may flow in the path of k-l-g-h-j by controlling the three-way control valve **172**, thus the hot water may be obtained by transferring the heat stored in the vessel **158** to the user.

The thermal storage system is further illustrated by the following examples, which are not to be construed in any way as imposing limitations upon the scope thereof. On the contrary, it is to be clearly understood that resort may be had thereof which, after reading the description herein, may suggest themselves to those skilled in the art without departing from the spirit of the specification and/or the scope of the appended claims.

EXAMPLE

Example 1

The Cooling Storage Using Night Time Electricity Refrigeration

A working system as depicted in FIG. 1 was set up. The vessel **18** contained about 150 kg of MPCM slurry with 29% hexadecane micro-capsules with mean diameter of 8 μm . The hexadecane was measured to have a melting temperature of 15.9° C., a primary solidification temperature of 13.3° C., and a latent heat of 138 J/g. An air-cooled chiller system supplied chilled water at the temperature of 10° C. to the first heat exchanger **20** during the night, to cool the MPCM slurry to a temperature of around 12° C. During the day, the chiller was

turned off, but the second heat exchanger **22** was able to supply cooled water at around 18° C. to a radiant ceiling panel in a demonstration room.

While the example of the thermal storage system have been described, it should be understood that the composition not so limited and modifications may be made. The scope of the system is defined by the appended claims, and all devices that come within the meaning of the claims, either literally or by equivalence, are intended to be embraced therein.

What is claimed is:

1. A thermal storage system, comprising:
 - a thermal storage device comprising an aqueous slurry of micro-encapsulated phase change material;
 - a thermal collector in a heat exchange relationship with said thermal storage device through a first heat exchanger; and
 - a thermal service device in a heat exchange relationship with said thermal storage device through a second heat exchanger,
 wherein said aqueous slurry of micro-encapsulated phase change material is configured to convert between solid and liquid states.
2. The system of claim 1, wherein said thermal storage device comprises a cold storage device, said thermal collector comprises a refrigerator, and said thermal service device comprises a cold service device.
3. The system of claim 2, wherein said cold storage device comprises a vessel for containing said slurry.
4. The system of claim 2, wherein said phase change material is selected from the group consisting of tetradecane, 1-bromohexadecane, hexadecane, and combinations thereof.
5. The system of claim 2, further comprising a first circulating pump for circulating a first heat transfer medium between said refrigerator and said slurry.
6. The system of claim 5, further comprising a control system for modulating said first circulating pump and said refrigerator, based on the reading of a first temperature sensor of said slurry temperature.
7. The system of claim 5, further comprising a second circulating pump for circulating a second heat transfer medium between said slurry and said cold service device.
8. The system of claim 7, wherein said cold service device comprises a cooling load.
9. The system of claim 7, further comprising a second temperature sensor for detecting temperature of the ambient.

10. The system of claim 9, further comprising a controller for modulating said second circulating pump, based on the reading of said second temperature sensor.

11. The system of claim 2, wherein said refrigerator comprises a compressor, a condenser, an expansion valve and an evaporator.

12. The system of claim 1, wherein said thermal storage device comprises a heat storage device, said thermal collector comprises a solar heat collector, and said thermal service device comprises a heat service device.

13. The system of claim 12, wherein said phase change material is selected from the group consisting of heneicosane, docosane, ttricosane, and combinations thereof.

14. The system of claim 12, further comprising a third circulating pump for circulating a third heat transfer medium between said solar heat collector and said slurry.

15. The system of claim 14, further comprising a fourth circulating pump for circulating a fourth heat transfer medium between said heat service device and said slurry.

16. The system of claim 15, wherein said heat service device comprises a heating load.

17. The system of claim 16, further comprising a control system for modulating said third circulating pump and said fourth circulating pump, based on the reading of a third temperature sensor of said slurry temperature.

18. A thermal storage system, comprising:

- a thermal storage device comprising an aqueous slurry of micro-encapsulated phase change material;
 - a thermal collector in a heat exchange relationship with said thermal storage device through a single heat exchanger; and
 - a thermal service device connected to said heat exchanger and said thermal storage device,
- wherein said aqueous slurry of micro-encapsulated phase change material is configured to convert between solid and liquid states.

19. The system of claim 18, further comprising an auxiliary electric heating system in heat transfer relationship with said thermal storage device.

20. The system of claim 18, further comprising a control system for modulating the thermal collector, based on the reading of a temperature sensor.

* * * * *