

Development of Packaging and Electrical Interfacing for Electrical Vehicles

C K Chan K.W.E.Cheng S.L.Ho

*Department of Electrical Engineering, The Hong Kong Polytechnic University
HungHom, Kowloon, Hong Kong. Email: caleb.chan@polyu.edu.hk*

Abstract – Electric Vehicle becomes more and more popular today. Not even major car manufacturers, small vehicle manufacturers are also developing electric vehicles. How to design a good electric vehicle? A good electric vehicle has high power efficiency, which can drive the vehicle to the maximum travelling distance between battery recharging. A series of electric vehicle has been examined, designed and tested. The design including battery, motor and gear. A prototype based on electric motor, battery and light body design has been developed. The vehicle is designed to be of low motor power and low speed operation.

1. Introduction

Recent years, many vehicle manufacturers start developing and manufacturing Electric Vehicles. Many different kinds of Electric Vehicles have been launched to the market. The number of different models has increased from years to years. Due to the limitation of Battery Technology, the only way to increase the range of the vehicle is to improve the efficiency of the vehicle. How to design an electric vehicle system which can fully utilize every bits of power? We should know more about the principle of designing a brand new vehicle first. The design of Electric Vehicle does not only affecting the appearance and the function of the Electric Vehicle; it also affects the efficiency of the entire power system.

In an Electric vehicle, the major electronic components are: Batteries, Motor, Motor Controller. To design an Electric Vehicle, First we need to identify the major function of that vehicle. There are different types of EV in the market. They are classified as Electric Neighbourhood Vehicles (Golf Kart), Private Electric Road Vehicles and Commercial Electric Road Vehicles.

For Electric Neighbourhood Vehicle, the Overall size is generally smaller and the weight which is less than 500Kg. The payload are generally lower. Also, they

are not permitted to drive on public roads. In the Motor Control System, the design is very simple. The Average voltage and current are about 24-48 Volts and 2-10kWh. Its average speed are not more than 40km/h. Inside the vehicle, it does not have any high power consumption devices such as Air Conditioning System and Heated Seats. Therefore the requirement of power from the drivetrain is very high..

For Road Private Vehicles, it is designed for longer range. The Gross weight is around 1,000kg – 1,500kg. The motor drives installed on the car are usually high voltage AC induction motor, mostly three-phase. The average voltage is about 110V and the power output is around 40-120 kilo-watt. Apart from motor drives, air-conditioner, heated seats and power windows are also consuming lots of power from the batteries.

Road Commercial Vehicle, which also designed for long range with heavy goods or large number of passengers. The Gross Weight is about 2,000kg – 4,000kg The power-train should be capable of heavy load. High Voltage and High Power motor will be used with the average of 400VAC and >60 kilowatt. Auxiliary Electric Appliances are also installed on these vehicles such as Air Conditioner and Cargo Lifter.

2. Components

Electric Motor – AC/DC Brush or Brushless drive. On new generation of low power Electric Vehicle, DC brushless drive will be used. The advantage is ease to maintain. Users are not required to renew the brush. However, the cost for DC Brushless Drive is higher than brush DC drives. Beside the Brushless DC Drive, Separately-excited DC Drive is also common. No extra components are required in this motor for regenerative braking.

Properties	Lead Acid	NiMH	Li-ion
Cell Voltage	2 Volt	1.2 Volt	3–4 Volt
Energy Density	25–30Wh/kg	35–80 Wh/kg	60–150 Wh/kg
Energy Efficiency	75–80%	60–85%	85–90%
Power Density	100–200 W/kg	100–1000Wh/kg	300–1,500W/kg
Service Life in Cycles	600 - 900	Over 2,000	Over 1,000
Operating Temp.	10–55°C	-20–55°C	-10–60°C

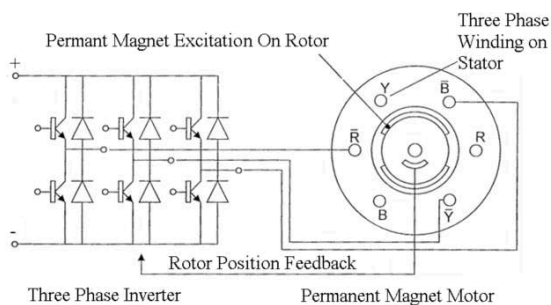

Fig 2.1. Components of DC Brushless Motor Drive

Switch Reluctance Motor is the motor which mounted phase coils diametrically opposite stator poles. The Rotor is made of Permanent Magnet. The energised phase will lead to the rotor moving into alignment with the stator poles. SR Motor gives better torque. In the diagram below, that shows a four-phase SR Motor. Five- and six-phase motors are also exists in the market. It can offer better torque ripple reduction compared with four-phase and three-phase.

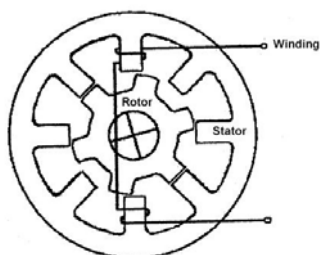

Fig 2.2. Switched Reluctance Motor Drive

Batteries – Lead Acid Batteries are the most common batteries used in low price and low power Electric Vehicles. The cost for these batteries is comparatively low. However, the Power Density is not as good as Nickel Metal Hydride (NiMH) and Lithium-ion (Li-ion). Also, the charging cycles are the worst among three. In the market, there are deep cycle batteries with provide longer service life charging cycles. Unfortunately, those batteries are larger, heavier than

normal batteries and it is more expensive too!!

Nickel Metal Hydride Batteries has higher Energy and Power density comparing with Lead Acid Batteries. Unlike Lead Acid Batteries, it must be sealed due to the inherent characteristics of the system. Low cell voltage cell means higher number of cells required than Lead Acid Batteries. The cost is higher than Lead Acid Batteries. However, it has longer service life cycles

Lithium Batteries has highest Energy and Power Density among three. Its working temperature is slightly higher than others. The voltage of each cell can be as high as 4Volt. However, the cost for using Lithium Batteries are high.

3. Other Factors affecting efficiency of EV

Frictions – Friction is one of the major problems affecting the efficiency of Electric Vehicle. Most of the friction on the Vehicle was come from tyres, running gears, differentials, Universal Joints, Drive-shaft Bearings...etc. In order to reduce friction, reducing the number of moving components is necessary. Thinner tyres can reduce friction. However, it may not have enough friction

to cope with the power from motor to wheels. In order to use thinner tyres, speed sensors can be added to each wheel to monitor the speed. If one of the wheels rotates faster than the others, that means there are spinning. Motor controller can cut the power of wheels in order to regain grip. Also, smaller diameter wheels can be used in order to give out enough torque. Moreover, direct drive motor is also a good way to reduce friction. The motor is mounted on the wheels directly. There are no gears are driveshaft so that it won't have any power loss. It also reduced the number of parts therefore it can also reduce the overall weight of the vehicle.

Aerodynamics, the topic always ignored by EV Designers. It is very important to Electric Vehicles, especially to those high power EVs. Aerodynamics

becomes very important when the vehicle are designed to travelling at speed over 40km,. Drags caused by the vehicle could increase the power consumption of the vehicle. Also, motor drives, controllers and batteries generate heat energy when the vehicle is running. Aerodynamic design could help to cool down electric components. Keeping all electric components in stable temperature can increase its efficiency and life time.

Weight is one of the major concerns on designing an electric vehicle. It affects the power-to-weight ratio. The major weight on the vehicle comes from chassis motor drive and transmissions. To reduce the weight, designers should use light weighted components and reduce the number of components. Direct Drive motor is one of the solutions.

To increase the comfort to the passenger, many advanced electric vehicles are equipped with many auxiliary equipments such as Air-conditioning, Hi-fi Stereo, Power windows, Electric Heated Seats....etc. These equipments consumes huge amount to power to operate. Therefore, high capacity batteries are required to keep those equipments operating without affecting too much on the overall performance.

4. Circuit topology for Electric vehicle

A. Driving circuits

In Electric Vehicle, H-Bridge inverters are popular to control and apply current to the motor. Inverter is a device which convert power from DC to DC or AC State. It can also be stepped up or down. Inverter can also reverse the rotating direction of the motor easily because it can control the power waveform. Most of the inverter using today are in Pulse-width modulation (PWM) waveforms.

Single Phase inverter is usually used in low power Electric Vehicle such as Electric Golf Kart. The circuit diagram is shown below:

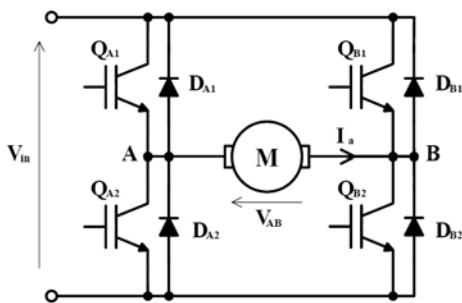

Fig 4.1 Single Phase Inverter Circuit Design

The Advantage of Single Phase inverter is that the circuit design is simple. Single Phase AC/DC motor are being used and it is suitable for low power electric vehicle such as Golf Kart.

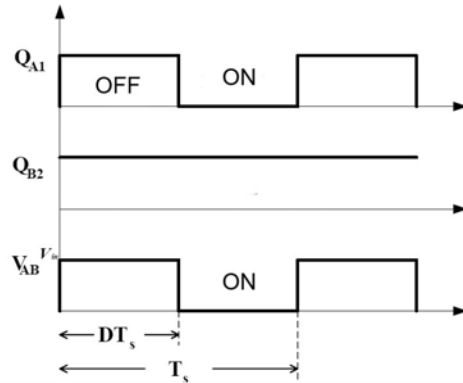

Fig 4.2 Single Phase Invert Operation Waveform

In High Power Electric Vehicle such as Road Vehicles, they use 3 phase AC Motors instead of the DC Motors in the past. Therefore, 3-phase inverters are being used to convert DC to 3 phase AC. To cope with high power, IGBT will be used instead of Mosfet because of its high efficiency. The diagram of Three Phase Inverter is shown below

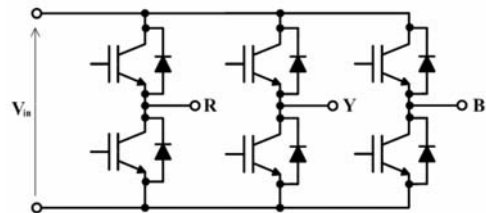

Fig 4.3 Three Phase DC/AC Inverter Circuit

Three Phase AC Inverter drives Three Phase AC Induction Motor. Three Phase AC Motor has better low speed torque and capable for high speed.

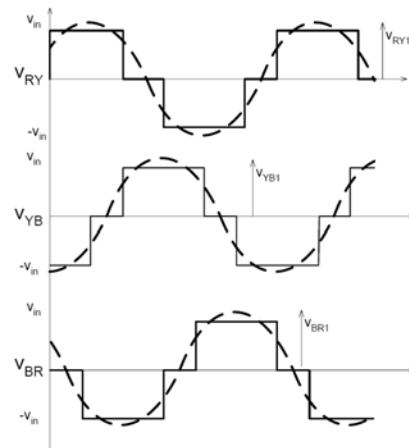

Fig 4.4 Three-Phase Inverter Operation Waveform

B. Car voltage

In Electric Vehicles, there are 12V, 24V, 42V 48V, 140V, 280V, or even higher power systems. Light weight electric vehicles such as Golf Kart with less than 4kW usually choose <48Volt system. The reason is that the system lower than 48V generally not requiring to comply with some of the regulation standards which is related to high power safety. Due to low voltage, the current for driving the motor is very high. Therefore there will be high losses from the cable, hence thick wire should be used. Thicker wire will increase the overall weight of the vehicle and cost. On High Voltage System, it is usually designed for Private Vehicle and Commercial Vehicles. Thinner wires can be used due to lower current. It benefits weight too.

5. Design equation for EV

5.1 Car Dynamics

During the process of designing an Electric Vehicle, series of calculations will be done before assembling the running prototype.

A. Calculation

Samples has been done. Assuming that:

- i. Golf Kart – Total Weight: 500kg; Coefficient of Drag: 0.35Cd; Headwind: 0m/s; Motor Power: 2kW; Largest Cross Section Area: $1.5m^2$, Battery: 12V 4x100A
- ii. Private Car– Total Weight: 1500kg; Coefficient of Drag: 0.35Cd; Headwind: 0m/s; Motor Power: 20kW; Largest Cross Section Area: $2m^2$; Battery: 12V, 6x100A

B. Motive Force.

$$F = \frac{M \cdot i}{r} \cdot \eta$$

Where:

F = Motive Force (Kg/h)

M = Motor Torque

i = Transmission Ratio

η = Drivetrain efficiency

r = Wheel radius

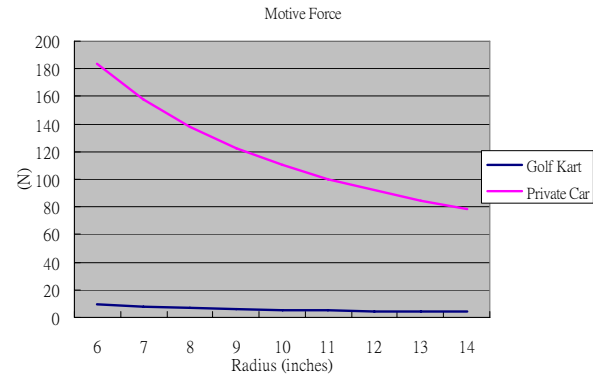

Fig 5.1 Motive force versus wheel radius

C. Climbing resistance and downgrade force.

$$F_{st} = m \cdot g \cdot \sin \alpha$$

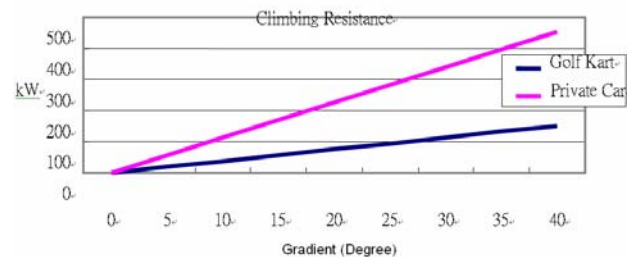

Fig 5.2 Climbing resistance versus gradient

Where:

F_{st} = Climbing Resistance (kW)

G = Weight ($m \cdot g$)

m = Vehicle mass

g = Gravitational Acceleration ($9.81m/s^2$)

v = Vehicle Speed

α = Gradient Angle

D. Aerodynamic Drag

$$F_L = 0.0386 \cdot \rho \cdot C_d \cdot A \cdot (v + v_o)^2$$

Where F_L = Aerodynamic Drag

ρ = Air Density

C_d = Coefficient of Drag

A = Largest Cross Section of the Vehicle

v = Vehicle Speed

v_o = Headwind Speed

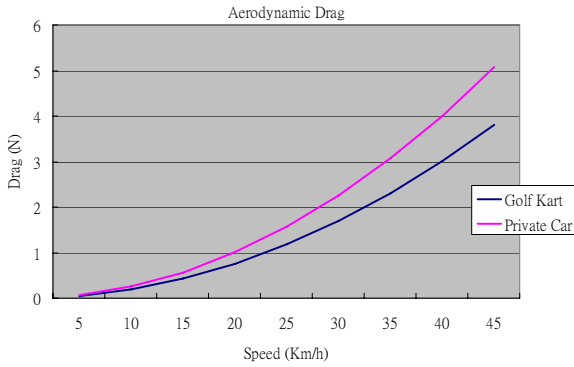

Fig 5.3 Aerodynamic drag versus vehicle speed

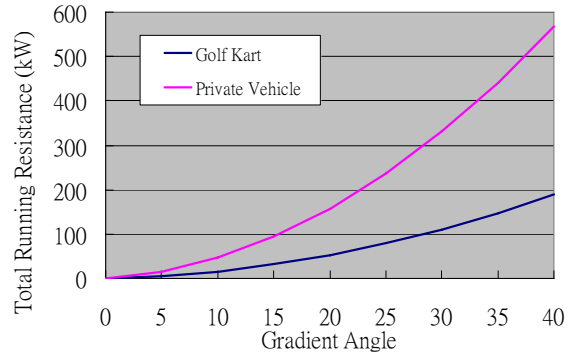

Fig 5.5 Running resistive power versus gradient

E. Rolling Resistance

$$F_{Ro} = f \cdot m \cdot g \cdot \cos \alpha$$

Where F_{Ro} = Aerodynamic Drag

f = Coefficient of Rolling resistance

m = Vehicle mass

g = Gravitational Acceleration ($9.81m/s^2$)

α = Gradient Angle

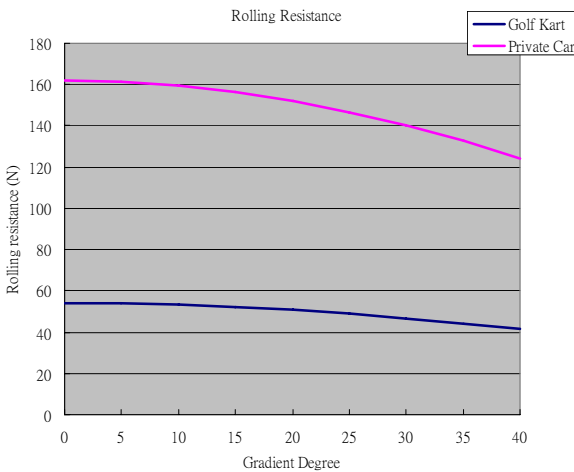

Fig 5.4 Rolling resistance versus gradient

F. Total Running Resistance

$$F_W = F_{Ro} \cdot F_L \cdot F_{St}$$

$$P_W = \frac{F_W \cdot v}{3600}$$

Where F_W = Running Resistance in N

F_{Ro} = Aerodynamic Drag

F_L = Aerodynamic Drag

F_{st} = Climbing Resistance

P_W = Running Power Resistance in kW

After all these calculations, the value of Motive Force should be higher than Total Running Resistance. Otherwise the vehicle is be able to move.

G. Total Running time in different motor voltage

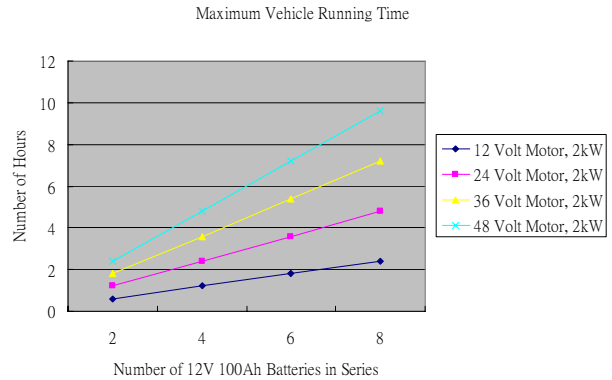

Fig 5.6 Running duration versus number of batteries

5.2 Weight

Weight is one of the major concerns in designing vehicle. Without affecting the stiffness of the vehicle chassis and maximum payload, lighter materials such as Carbon Fibre, Glass Fibre, Graphite and Aluminium Alloy are now being used in electric vehicles. By using these kinds of materials, power to weight ratio and the overall range has significant improvement. Direct Drive could also reduce the number of mechanical parts. The Direct Drive Motor is built in together with the wheel. This design is good for 4 wheel drive vehicle because smaller motor can be used in each wheel and the power can be actively transfer to every wheel according to their traction. Brakes and Regenerative braking can also be done in the motor on every wheel. However, this type of direct drive motor may not suitable for sports electric vehicle. The reason is the weight of the wheels will be heavier than

normal wheels and it may increase the load of the suspension system. This harm the overall handling and stability to the vehicle and the vehicle may be rolled over easily.

In gasoline vehicles, brake by wire, steer by wire system are now being developed. On electric vehicle, the same system can also be applied. Direct Drive Motor can be a part of brake system. When the brake paddle is pressed by the driver, the hall-sensor from the brake paddle detects the amount of braking required from the driver and transmits the signal to the power controller. The controller will receive the power from the motor and charge it back to the battery. The vehicle will slow down.

On Steer by wire system, the Steering angle will be received by the steering angle sensor and sent to the steering controller. After processing, the signal will be transmitted to the stepping motor at the front wheel. The advantage is that the controller can detects the dynamics of the vehicle and adjust the angle of front wheels to avoid losing control at high speed.

A mycarTM has been developed as shown in Fig 5.7-5.9. It is driven by electric motor with a step-down 4:1 gear box. The car is designed for village car and the maximum speed is limited to 30kph and with normal speed 20kph..



Fig 5.7: Gear and universal joint of the EV



Fig 5.8 Motor and the step down gear



Fig 5.9 Proposed EV to be developed: mycarTM

6. Conclusion

Designing a good electric vehicle is not an easy task. We need to fully understand the need of that vehicle and choose the right vehicle package and components in order to maximize its overall efficiency. Electric Vehicles with complicated electronic power controls will be the trend of future electric vehicles.

The town car versions of an Electric vehicle has been studied, designed and under construction. The electrical interfacing, battery size, motor size and the users' requirement has been examined. A town car based on Golf kart has been tested and the starting, running and braking characteristic has been examined. The characteristics will then be used to design the town car. The "MyCar" version is now under construction. Also the all-electric version of Mercedes "Smart" is also under designed.

Acknowledgement

The authors gratefully acknowledge the support of the research office and the teaching company scheme of the Hong Kong Polytechnic University under the project RGGN and Innovech Technology Ltd.

References

1. SAE Electric Vehicle Inductive Coupling Recommended Practice, SAE 5-1773, (draft) Feb. 1, 1995.
2. E.X. Yang, Y.M. Yang, G.C. Hua, F.C. Lee, "Isolated Boost Circuit for Power Factor Correction," IEEE-APEC Conf. Rec., 7-11 March 1993 pp. 196 - 203
3. N. Machin, T. Vescovi, "Very High Efficiency Techniques and Their Selective Application to the Design of a 70 A Rectifier." 15th International Telecommunications Energy Conference, 1993. INTELEC '93, 29 Oct.-1 Nov. 1995, pp.:29 - 34
4. G.C. Hua. C.S. Leu, Y.M. Jiang, F.C. Lee, "Novel Zero-Voltage Transition PWM Converters," IEEE PESC'92 Conf. ., pp. 53- 61.
5. R.L. Stiegerwald, "High Frequency Resonant Transistor DC-DC Converters," IEEE Transactions on Industrial Electronics, vol. IE- 31, May 1984, pp. 181-191.
6. J. Hayes, J. Hall, M. Egan, J. Murphy, "Full Bridge, Series- Resonant Converter Supplying the SAE J- 1773 Electric Vehicle Inductive Charging Interface," IEEE PESC'96 Conf. Proc., Vol. 2, 23-27 June 1996, pp. 1913 – 1918.
7. N.H. Kutkut, D.M. Divan, D.W. Novotny, R. Marion, "Design Considerations and Topology Selection for a 120 kW IGBT Converter for EV Fast Charging" IEEE-PESC Conf. Rec., pp. 238- 244, 1995.
8. Y.M. Jiang, H. Mao, F.C. Lee, D. Borojevic, "Simple High Performance Three-Phase Boost Rectifiers," IEEE PESC'94 Conf., pp. 20-25, 1994.
9. V. Vlatkovic, D. Borojevic, F.C. Lee, "Soft-Transition Three-phase PWM Conversion Technology," IEEE-PESC Conf., pp. 20- 25, 1994.
10. D.M. Divan, "The Resonant DC Link Converter - A New Concept In Static Power Conversion," IEEE-IAS Conf. Rec., pp. 648-656, 1986.
11. K.W. Klontz, N.H. Kutkut, "Design Considerations of Extremely Fast Charging Systems for Electric Vehicle" Thirteenth International EV Symposium (EVS-13) Conf. Rec., pp. 751-758, 1996.