

# Converter Topologies for Alternative Energy

CHENG K.W. Eric  
Department of Electrical Engineering  
The Hong Kong Polytechnic University  
Hong Kong  
E-mail: eecheng@polyu.edu.hk

**Abstract**—The paper discusses the power electronic converter used in alternative energy processing system. There are a number of DC-DC power conversions and AC-AC power conversions that are needed for the alternative energy power units. The merit and drawback of each is discussed.

## I. INTRODUCTION

Power Processing is an important element for alternative energy source and subsystems. For electricity generated by alternative energy, most of them must be reconditioned so that it can be used for general public or connected to the power line. Circuits and systems that are available in the past are mostly concentrated on the slow power switching devices such as thyristor, bipolar transistor and they are not reliable, slow dynamic response and difficult to design. On the other hand, today, most of the electricity generated by alternative energy or the associated energy storage system is output in DC. Therefore there is a large score for the DC power processing research and development on the areas such as photovoltaic cell and fuel cell. Certain systems may also generate the power in AC form, such as induction or synchronous generator and their output voltage or frequency may not be maintained fixed or easier to be controlled. Therefore power processing is therefore needed.

Even for the DC processing, there is consideration for the different topologies for the DC to DC converters. Also the DC-AC converters, there are also different types of inverter circuits available for selection. For AC-AC power conversion, there are matrix converter, back-to-back converter system and VFCF converters available. This paper is to discuss the possible method for the power processing in the areas.

## II. DC-DC POWER CONVERSION

### A. Schematic

As most of the appliances are operated on DC such as computer, electronic ballast, washing machine, audio and video system, entertainment electronics, etc. Therefore it is more economic to produce DC and directly to drive the appliances. The output voltage for a photovoltaic (PV) cell and is relative low and such a small voltage is not efficient for directly input to a DC-DC converter. Therefore most of the cases, a series connection of the photovoltaic cell are connected in series or array. Fig 1 shows a typical connection of a PV system. The DC-DC converter is to convert the DC voltage produced by the PV array to a suitable level. It also provides the maximum power tracking so that a maximum power can be derived from the cell [1-2]. It also provides the DC isolation by using high frequency transformer. Most of the systems is

connected with an energy storage system such as battery. The power stored in the battery can be restored to external system through the DC-DC converter. If AC is needed, an inverter is used to invert the DC into AC.

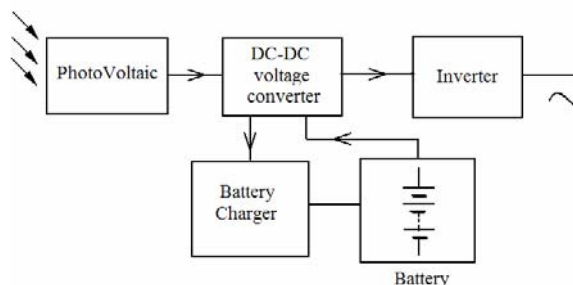

Fig 1: PV system with typical power processing

### B. Voltage requirement of the DC-DC converter

As discussed, the DC-DC converter serves a few functions for voltage conversion purposes:

- Connect to a battery charger
- Convert suitable output voltage to the inverter
- Convert the battery voltage back to suitable level for the inverter

The DC-DC converter is to convert the PV voltage to suitable DC voltage  $V_{DC}$ . The usual output voltage  $V_{AC}$  from the inverter is to give 380V. Therefore inverter equation is:

$$V_{DC} = \frac{2\sqrt{2}V_{AC}}{M} \quad (1)$$

where M is the modulation index is can be varied from 0.4 to 1.15. Too small M gives poor harmonic spectrum that is to be avoided. The typical value selected is 0.9. The DC-DC converter is also used as a buffer to the battery charger. Some battery charger is integrated with the DC-DC converter as a single unit can be connected directly to the PV.

### C. Isolation converter

Because of the DC isolation is needed for safety, electromagnetic precaution and international standard, the output stage must be isolated from the PV through transformer. Mains frequency transformer can be connected to the inverter output but the transformer size is usually large and therefore it increases the cost and size. With the rapid development of power electronics, high frequency transformer that is integration with the DC-DC converter is used. It can also provide suitable DC isolation and its power density is high, usually higher than  $1W/cm^3$  is available. For small power applications, the forward or flyback converters as shown in Fig 2 are usually used. Their application is usually to be less than

500W. For medium power such as 300W-1kW, the two-transistor version can be used. For higher than 1kW, the H-bridge version should be used. The transformer can usually put more than one secondary winding to give multiple output voltages to serve different DC output requirements.

**Table 1: Topology for the DC-DC converter**

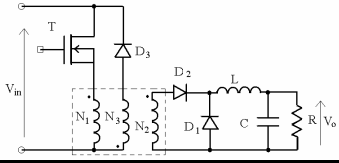
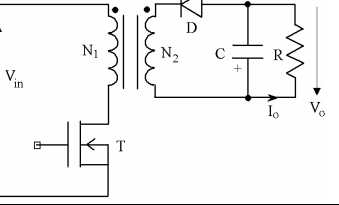
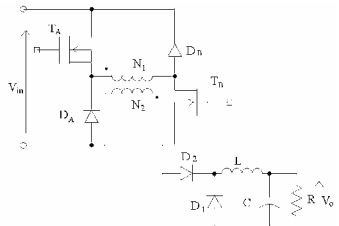
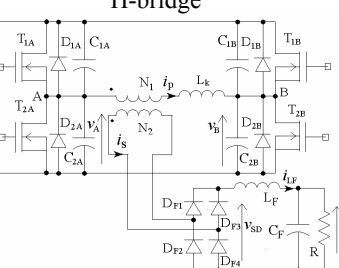
Topology	Voltage conversion	$\frac{V_o}{V_{in}}$
<p>Forward</p> 	$\frac{N_2}{N_1} d$	
<p>Flyback</p> 	$\frac{N_2}{N_1} \frac{d}{1-d}$	
<p>Two-transistor Forward</p> 	$\frac{N_2}{N_1} d$	
<p>H-bridge</p> 	$\frac{N_2}{N_1} \frac{\delta}{\pi}$	

In the table,  $d$  is the transistor duty ratio,  $\delta$  is the phase angle between inverter leg A and leg B. The H-bridge converter is the most suitable for high power applications. They also have the additional advantage of soft-switching. This is provided by the parallel capacitors  $C_{1A}$ ,  $C_{1B}$ ,  $C_{2A}$  and  $C_{2B}$ , to form the zero-voltage switching.

### III. BATTERY CHARGER

The battery charger is able to provide at a number of stages of charging mechanism including constant voltage, constant current, trickle and/or pulse charging. The battery charging circuit should be able to provide bi-directional power flow so that it can provide a path for the battery voltage feedback to the load circuit. The DC isolation can be provided by the DC-DC converter as

shown in Section II. Table 2 shows a series of the battery charging topologies for the applications.

#### A. Circuit topology

The following shows a typical list of the circuit topology for the battery charger. In the table  $d$  is the duty ratio of transistor  $T_1$ .

**Table 2: Topology of the battery charging circuit**

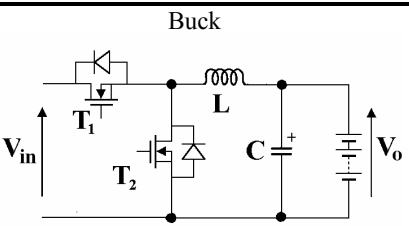
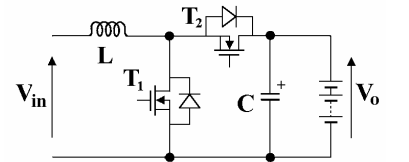
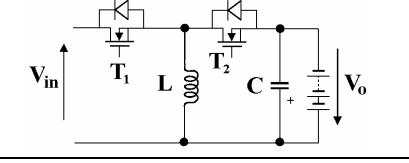
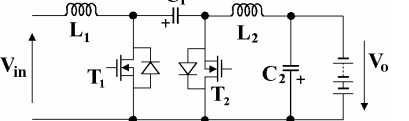
Topology	Voltage conversion	$\frac{V_o}{V_{in}}$
<p>Buck</p> 		$d$
<p>Boost</p> 		$\frac{1}{1-d}$
<p>Buck-Boost</p> 		$\frac{d}{1-d}$
<p>Cuk</p> 		$\frac{d}{1-d}$

#### B. Comment on topologies

The Buck version is a popular circuit can provide step down from PV array or main DC-DC converter to the battery. Its output stage is built in with a choke  $L$  and therefore its ripple to the battery is small. In the circuit  $T_1$  and  $T_2$  are responsible for the main and auxiliary transistors respectively.  $T_1$  is for delivering the energy from the input side to the battery whereas  $T_2$  is to feedback the battery energy back to the  $V_{in}$  stage.

The Boost version is to boost up the  $V_{in}$  to higher voltage. Therefore it is suitable for the battery voltage is higher than the PV array voltage or the main DC-DC output voltage. The current ripple of the input stage is particularly low and is suitable for low electromagnetic interference (EMI) to other circuits.

Both the Buck-Boost version and the Cuk version can provide a wide range of battery voltage version as compared with the input. The voltage conversion of them can be step up or down that depends on the transistor duty ratio  $d$ . The Cuk version has the additional advantage of

low ripple in both output voltage and input current, but the drawback is that it has higher component count.

The above four examples can be with the voltage conversion from order 1 to 3 of magnitude. For higher of magnitude of voltage conversion, a transformer isolation version should be used. The circuits in Table 1 can be used. The bi-directional power flow version of the circuit in Table 1 is discussed as follows:

#### D. Isolated version

A review on Table 1 circuit, the bi-directional power flow version has to change the diode D into transistor. For the Forward conversion, the D<sub>1</sub> and D<sub>2</sub> are needed to change to transistor. This circuit is so called the isolated-boost [3] and it has more transistor than the other circuit therefore it is not economic.

The bi-directional version of the flyback conversion is just to change diode D into transistor. The flyback converter is just a Buck-boost with a coupled inductor instead of an inductor. It is the same voltage conversion ratio as it is viewed from either end.

### IV. INVERTER TOPOLOGY

For three-phase version, it is basically a full-bridge version with 3 inverter legs (3 pair of transistors). Fig 2 shows a typical 3-phase inverter which is a DC-AC converter. The inverter is fired by pulse-width modulation signals which give sinusoidal output voltage. The output form the inverter should be filtered to remove the high frequency switching signal.

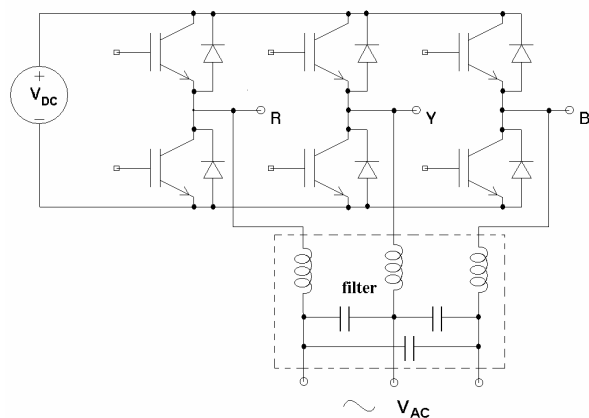

Fig 2: Typical inverter topology

The input voltage  $V_{DC}$  to the inverter is related to the output voltage  $V_{AC}$  by the eqn (1).

### V. DESIGN CONSIDERATION

#### A. Basic design

The basic design concept actually depends on the efficiency of each unit, the power output of the source and the load power. It also depends on how the load consuming power and the period of sustainability. The last item mainly controlled by the energy storage components such as the storage capability of the battery. All the above factors will also decrease with age and therefore some tolerance will be added for the design. IN most of case, the design equations are all empirical and it also varies with manufacturers' data.

#### B. Efficiency

The efficiency of each subsystem affects the design and the selection of the power rating of each. The basic selection of the power level of the photovoltaic panel, battery capability and the output power are related by the following simplified equation. The equation is based on the charging and discharging cycle for 1 day.

$$P_{PV} I_{PV} \eta_{DC} \eta_{BC} \eta_B T_{su} = P_o T_{LD} \quad (2)$$

$$I_B V_B > \frac{P_o}{T_{LD}} \quad (3)$$

where

$P_{PV}$  is the rated power of the solar panel

$I_{PV}$  is the average efficiency of the solar panel during the operation, this factor relates to the luminous radiation intensity and changes with time and days.

$\eta_{DC}$  is the efficiency of the power conditioning DC-DC converter, and it is usually around 70-95%

$\eta_{BC}$  is the efficiency of the battery, and it varies among the type and age of the battery. It is usually around 60-85%.

$T_{su}$  is the average number of hours of sunlight

$P_o$  is the average load power

$T_{LD}$  is the average usage hour of load

### V. VFCF TOPOLOGY

There are a number of generators available for renewable energy such as power derived from wind, tidal power, biomass, hydro; and some combustion generator from green gas such as hydrogen are all major electricity generation means. There are a number of methods that the generator can be conditioning. For examples, some system uses doubly-feed generator [4], synchronous generator [5] or induction generator [6], switched reluctance generator. Some generator produces variable frequency and variable voltage output and in the past a mechanical system is needed to regulate the output stage in order to produce constant frequency and voltage. Alternatively a variable frequency-constant frequency converter can be used to reduce the mechanical system that of course has the advantage of reduction in the bulky system. The converter also allows the variable frequency operation of the wind turbines in order to keep the ratio of the rotor speed derived from wind to the inflow wind speed constant to optimize the performance. There are a number of topologies suitable for the applications. They are AC-DC-AC converter, matrix converter and cycloconverter.

#### A. AC-DC-AC converter

Basically the system is based on a cascade connection of a AC-DC and a DC-AC inverter [7]. The intermediate stage is a DC stage which has some capacitor or even battery for intermediate energy storage and voltage smoothing. Fig 3 shows a typical schematic. The capacitor  $C_{DC}$  or the battery  $B_{DC}$  can also provide a prolonged uninterrupted time in case the input stage fails to supply. The AC-DC is usually a rectifier or an AC-DC power factor correction rectifier. The DC-AC inverter is a circuit the same as the Fig 2.

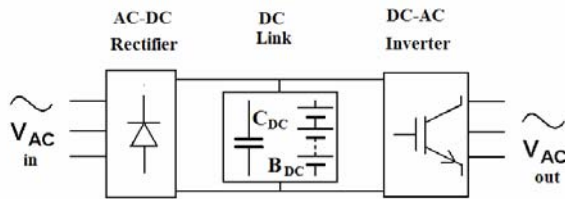

Fig. 3: AC-DC-AC converter system

### B. Matrix Converter

Fig 3 shows a typical matrix converter for AC-AC power conversion [8]. The output voltage and frequency can be varied so that it is a good candidate renewable energy generator. No intermediate energy storage such as capacitor is needed.

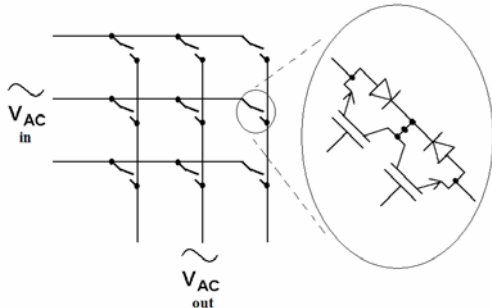

Fig. 4: Matrix converter for AC-AC power conversion

### C. Discussion

Both AC-DC-AC converter and the matrix are suitable for the VFCF application. The matrix converter uses 18 transistors but it does not require capacitors. The AC-DC-AC converter requires DC link capacitor its switching devices needed are 6, but if the front-end converter AC-DC rectifier is replaced by active devices, the total transistor needed is 12. The cycloconverter [9] has a less flexibility on voltage and frequency control and is less popular.

### CONCLUSION

The paper discusses a number of topologies that can be used in alternative energy electrical system. This includes the PV array power conditioning converter, associated DC-DC converters, battery charger and inverter. The high frequency technology is used for all the power conversion units. The DC isolation is provided by the isolated DC-DC power conversion. The battery charger is designed by bi-directional circuit so that it can provide both charging and discharging capability. The design method is discussed and it highly depends on empirical formulated and manufacturer. A tolerance is needed to tolerate for the environmental and parameter changed is needed.

On the whole, power electronics gives a new era for power conversion. The power density of the power processing units are all increased. This also comes to the fact that associated materials, chassis, protection devices and control, electronics are simpler and lower in cost. With the rapid development in both power devices, new topology and control method, the future power processing of alternatives energy will be more efficient and higher efficiency.

### ACKNOWLEDGE

The author gratefully acknowledges the Research Committee, the Hong Kong Polytechnic University for the support of the work.

### REFERENCES

- [1] Kuo Y.C.; Liang T.J.; Chen J.F.;, Novel maximum-power-point-tracking controller for photovoltaic energy conversion system, IEEE Transactions on Industrial Electronics, Vol. 48, Issue 3, June 2001, pp.594 – 601.
- [2] Solodovnik, E.V.; Shengyi Liu; Dougal, R.A.;, "Power controller design for maximum power tracking in solar installations", IEEE Transactions on Power Electronics, Vol. 19, Issue 5, Sept. 2004 pp.1295 – 1304.
- [3] Cheng K.W.E., "Classical Switched-mode and resonant power converters, The Hong Kong Polytechnic University, Chapter 3, ISBN: 962-367-364-7, Sep 2002, pp. 78-80.
- [4] Pena, R.; Clare, J.C.; Asher, G.M.; "Doubly fed induction generator using back-to-back PWM converters and its application to variable-speed wind-energy generation", IEE Proceedings-Electric Power Applications, Vol. 143, Issue 3, May 1996, pp.231 – 241.
- [5] Karrari, M.; Rosehart, W.; Malik, O.P.; "Comprehensive Control Strategy for a Variable Speed Cage Machine Wind Generation Unit", IEEE Transactions on Energy Conversion, Vol. 20, Issue 2, June 2005, pp.415 - 423
- [6] Blaabjerg, F.; Zhe Chen; Kjaer, S.B.; "Power electronics as efficient interface in dispersed power generation systems", IEEE Transactions on Power Electronics, Vol. 19, Issue 5, Sept. 2004, pp.1184 – 1194.
- [7] Thomas, R.J.; Phadke, A.G.; Pottle, C.; Operational characteristics of a large wind-farm utility system with a controllable AC/DC/AC interface", IEEE Transactions on Power Systems, Vol. 3, Issue 1, Feb. 1988, pp.220 – 225.
- [8] Chang, J.; Wang, A.;, "Experimental development and evaluations of VF-input high-frequency AC-AC converter supporting distributed power generation", IEEE Transactions on Power Electronics, Vol.19, Issue 5, Sept. 2004, pp.1214 – 1225.
- [9] Brown, G.M.; Szabados, B.; Hoolbloom, G.J.; Poloujadoff, M.E.; "High-power cycloconverter drive for double-fed induction motors", IEEE Transactions on Industrial Electronics, Vol. 39, Issue 3, June 1992, pp. 230 - 240