

Automobile Hybrid Air Conditioning Technology

Y.P.B.YEUNG¹ K.W.E.CHENG¹ W.W.CHAN¹ C.Y.LAM¹ W.F.CHOI¹ T.W.NG¹

¹Department of Electrical Engineering, the Hong Kong Polytechnic University, Hong Kong
E-mail: eebyeung@polyu.edu.hk

Abstract-A newly developed hybrid air conditioning system for automobile is introduced. In this system, the air condition compressor is driven by an internal combustion engine of the vehicle when the engine is running. When the engine is not running, the compressor is driven by a brushless DC machine powered by a 24V lead acid battery. The electric machine driven generates electric power for charging the battery. The concept and the structure of this air conditioning system are discussed in this paper.

Keywords-Automobile, vehicle, air condition

I. INTRODUCTION

Air conditioning system provides the human comfort environment by controlling suitable range of air temperature and humidity in the living environment. The history of air conditioning system is over one century since 1902. In 1939, the world first air conditioning system for automobile was developed by Packard Motor Car Company. In 1969, more than 50% automobile sold in US are equipped with automobile air conditioning system. Nowadays, automobile air conditioning system becomes necessity equipment in the automobile industries, especially for the great markets in tropical and subtropical geographical areas such as South China.

Fig. 1 shows the diagram of the basic structure of a traditional automobile air conditioning system. Similar to typical air conditioning systems, a typical automobile air conditioning system consists of an air condition (A/C) compressor, a condenser, a valve and an evaporator. Refrigerant flows in the tube to the parts of the air conditioning system. Evaporated refrigerant (low side) is compressed by the A/C compressor and discharged out (high side) with high gas pressure in the results of higher heat energy generation. Heat generated to the refrigerant will be dissipated by the condenser with forced air cooling. When the temperature of the refrigerant decreases, a phase change (in gas to liquid phase) of the refrigerant is condensed and the liquefied refrigerant is fed into the evaporator with pressure release action. During pressure release, the phase change (from liquid to gas phase) of the refrigerant absorbs energy from the environment, and the cooling effect takes place. This series of actions repeats to the low side to complete the refrigeration cycle [1-2].

In automobile air conditioning system, the A/C compressor is driven by the engine of the vehicle [3]. The clutch in Fig.1 is an electromagnetic clutch which is integrated in most A/C compressors. A/C temperature control relies on switching the on and off position of the clutch. This structure is simple and easy for maintenance. However, the speed of the engine changes frequently in a wide range of speed when the vehicle is running on the road. The speed of the compressor changes independently

with the A/C temperature and hence the A/C temperature fluctuates. Another disadvantage of the traditional air conditioning system is that the air conditioning system has to be shut down when the engine is shut down (vehicle off).

A newly designed automobile hybrid air conditioning system is introduced in this paper. The concept of this air conditioning system is combining the technology of electric and traditional automobile air conditioning systems.

The compressor of this system is driven by the internal combustion engine when the engine is running as a typical automobile air conditioning system. When the engine is shut down, the A/C compressor of this system is driven by an electric machine powered by a 24V rechargeable battery. When the battery voltage level is low, it is recharged by the electric power generated from the same electric machine driven by the engine. Since the speed of the electric machine is under control, the A/C temperature can be controlled with much less temperature fluctuation.

II. STRUCTURE OF AUTOMOBILE HYBRID AIR CONDITIONING SYSTEM

Like a traditional automobile air conditioning system, the structure of the automobile hybrid air conditioning system includes an A/C compressor integrated with an electromagnetic clutch, a valve, a condenser, an evaporator, belts and belt pulleys. The compressor in this system can be electric driven so that the system also consists of an electric machine, a motor drive, a 24V rechargeable battery, a battery charger, and a control unit. Clutches are also used for switching the mechanical power sources to the A/C compressor between the combustion engine and the electric machine. The diagram of structure of the automobile hybrid air conditioning system is shown in Fig. 2.

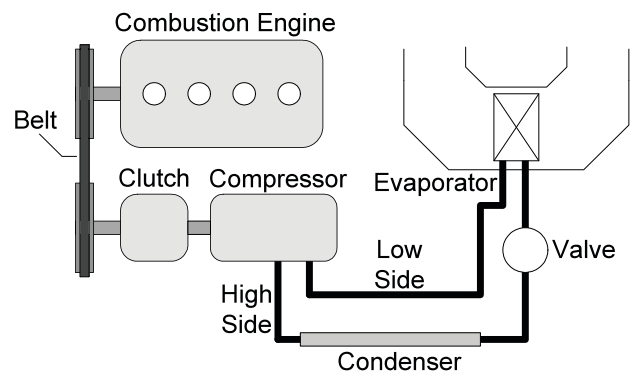

Fig.1: Basic structure of traditional automobile air conditioning system

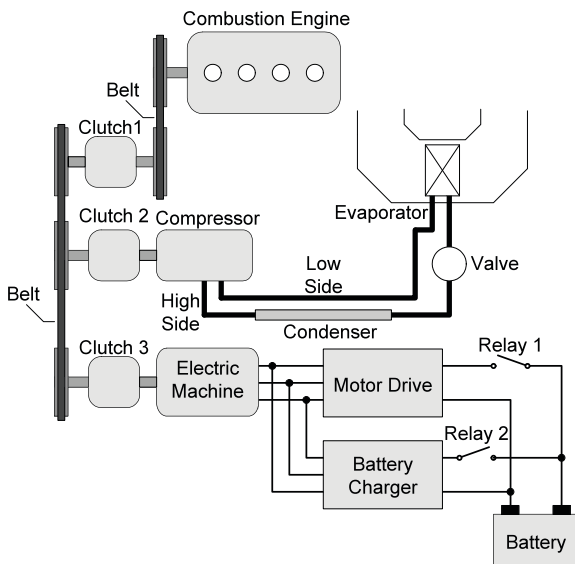

Fig. 2: Diagram of structure of the automobile hybrid air conditioning system

The electric machine of this air conditioning system is a brushless DC (BLDC) machine. This kind of machine is used because of its fast response, high power density, robust and high reliability. This BLDC machine is for both driving the compressor and for generating electric power for charging the battery. The BLDC machine is driven by a motor drive system.

III. OPERATION OF AUTOMOBILE HYBRID AIR CONDITIONING SYSTEM

The operation of the automobile hybrid air conditioning system is classified to 5 modes of operation. The equivalent diagrams of the modes of operation of the air conditioning system are shown in Fig 3. The modes of operation are described in the following:

1. Mode 1

The combustion engine is running in Mode 1. The vehicle is on and the air conditioning system is on. The battery is fully charged. Clutch 1 is close. Relay 1, Relay 2 and Clutch 3 are open. The combustion engine drives the A/C compressor. The electric machine is not operated. The battery is not recharged. The room temperature is controlled by switching on and off Clutch 2, i.e., switching on and off of the A/C compressor.

2. Mode 2

The vehicle is stop in Mode 2. The combustion engine is not running in this moment but the air conditioning system is on. Clutch 1 and Relay 2 are open. Clutch 2, Clutch 3 and Relay 1 are close. The battery produces electric power to the motor drive to drive the electric machine, and the electric machine drives the A/C compressor. The room temperature is controlled by controlling the speed of the electric machine by the motor drive and the control unit. This obtains stable temperature and saves compressor starting energy. The electric machine stops when the voltage of the battery reaches its lowest discharge voltage.

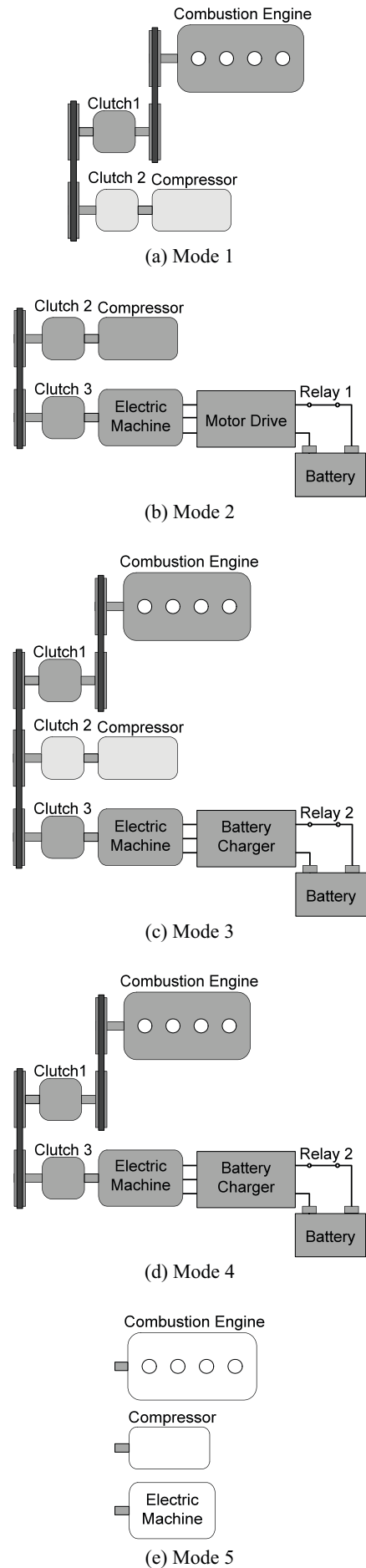

Fig. 3: Equivalent diagrams of operation of the automobile hybrid air conditioning system

3. Mode 3

The vehicle is running in Mode 3 so that the combustion engine is running in this moment. The air conditioning system is on. The battery is recharged because its voltage level is low. Clutch 1, Clutch 3 and Relay 2 are all close. Relay 1 is open. The combustion engine drives both the A/C compressor and the electric machine. The electric machine generates electric power to the battery charger to charge the battery. The room temperature is controlled by switching on and off Clutch 2.

4. Mode 4

The air conditioning system is off in Mode 4. The combustion engine is running. The battery is recharged because its voltage level is low. Clutch 1, Clutch 3 and Relay 2 are close. Clutch 2 and Relay 1 are open. The combustion engine drives only the electric machine. As in Mode 3, the electric machine generates electric power to the battery charger to recharge the battery.

5. Mode 5

The air conditioning system is off in Mode 5. The combustion engine is either running or stop. The battery is fully charged. The electric machine does not neither drive the A/C compressor nor generate electric power. Clutch 1, Clutch 2, Clutch 3, Relay 1 and Relay 2 are all open.

IV. DESIGN OF PROTOTYPE OF AUTOMOBILE HYBRID AIR CONDITIONING SYSTEM

A prototype of the automobile hybrid air conditioning system has been designed for a Toyota Corolla AE110 1.5L sedan. The test car was modified for fitting the parts of the air conditioning system. The A/C compressor is Denso TV12C compressor. It is a 24V system. Fig. 4 shows the test car.



Fig. 4: Figure of Test Car

The battery charger for the automobile hybrid air conditioning system has been designed. The motor drive is designed and produced by the electric machine manufacturer so that motor drive design is not included in this project. Before designing the battery charger, performance of electric generation function of the electric machine was tested. A BLDC machine is used in the prototype. Its specification is shown in Table 1.

The BLDC machine generates 3-phase trapezoidal wave AC voltage. From experiment for testing the electric generation performance of the BLDC machine, it shows that the measured maximum rms output line voltage of the machine is 16.37V at 2400rpm and at no load. The measured average rms voltage drop per ampere is 0.0285/A when the BLDC machine is loaded. The measured maximum frequency of the voltage is 80.4Hz. Fig. 5 shows the output voltage waveform of the machine. Fig. 6 and Fig. 7 show the characteristics of output voltage and frequency of the machine at no load, respectively.

Table 1: Specification of the electric machine for the prototype of automobile hybrid air conditioning system

Machine Type	Brushless DC
Nominal input voltage	24V
Maximum input voltage	30V
Minimum input voltage	18V
Maximum input current	70A
Maximum output power	1.7kW
Rated speed	2400rpm
Insulation grade	H grade
Wiring	Y connection
Protection	IP44
Weight	20kg

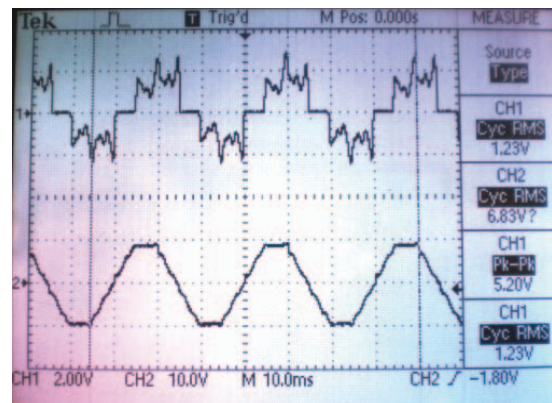

Upper trace: Output current, 2A/div
Lower trace: Output voltage, 10V/div
Time base: 10ms

Fig. 5: Measured output waveforms of the BLDC machine

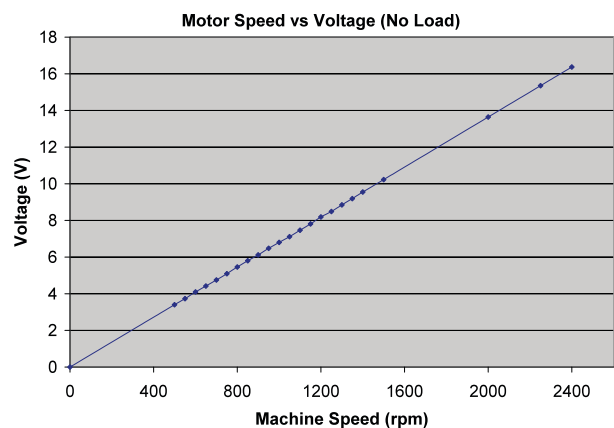

Fig. 6: Characteristic of output voltage of the BLDC machine at no load

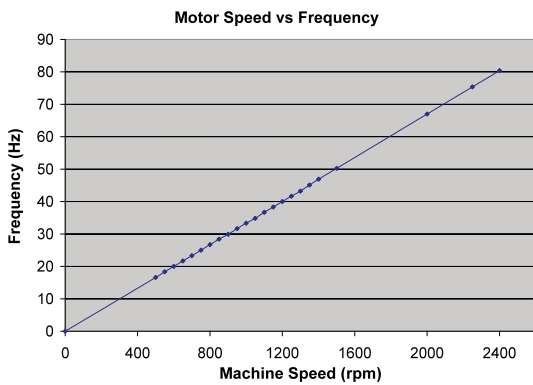

Fig. 6: Characteristic of measured frequency of the BLDC machine

This air conditioning system was designed for working for at least 30 minutes in Mode 2. Additional two 12V 150Ah deep cycle lead acid batteries are used in the prototype instead of using the existing 12V car battery. The batteries are connected in series to provide 24V nominal voltage to the motor drive. The total voltage range of the batteries is from 19.2VDC to 28.8VDC.

Forward converter topology is used in the prototype of this air conditioning system. Because the input voltage of the battery charger depends on the speed of the BLDC machine and the output rms voltage range of the BLDC machine is very wide which is from 0V to 16.37V, the battery charger cannot operate under full from of the speed of the BLDC machine. The battery charger operates only when the speed of the BLDC machine between 500rpm to 2400rpm. Avoiding very high input current when the speed of the BLDC machine is low, charging current of the battery charger is varied with different machine speed. The specification of the battery charger is shown in Table 2. The relation between the charging current and the speed of machine is shown in Table 3. The schematic diagram of the battery charger is shown in Fig. 7. Since the input voltage of the battery charger is low, the battery charger operates with high switching frequency. The switching frequency is 100kHz. The list of components of power circuit of the battery charger is shown in Table 4. The output voltage of the BLDC machine is AC, the battery charger rectifies the output voltage of the BLDC machine to DC by a 3-phase full bridge rectifier consisted by D1 to D6 before processing DC to DC power conversion. The output line voltage of the BLDC machine is 3-phase trapezoidal wave AC voltage which their upper and lower edges are 1/6 of the period of each line voltage waveform and hence large capacitance of filtering capacitor of the rectifier is not needed.

The battery charger operates under average current mode control. Atmel ATtiny861 8-bit with high frequency PWM output microcontroller is used for the battery controller. Battery voltage, charging current, input voltage and speed of the BLDC machine are sensed and input to the microcontroller. PI control, charging current selection and charging schemes selection are built in the MCU programme. The flow chart of the MCU programme is shown in Fig. 8.

Table 2: Specification of battery charger for the prototype of automobile hybrid air conditioning system

Minimum input line voltage	3.2Vrms
Maximum input line voltage	17Vrms
Nominal battery voltage	24VDC
Minimum battery voltage	19.2VDC
Maximum battery voltage	28.8VDC
Maximum charging current	20A
Switching frequency	100kHz
Battery capacity	150Ah

Table3: Relationship between speed of machine and charging current of the battery charger

Speed of BLDC Machine (rpm)	Battery Charging Current (A)
≥0 and <500	0
≥500 and <750	6
≥750 and <1000	8
≥1000 and <1250	10
≥1250 and <1500	12
≥1500 and <1750	14
≥1750 and <2000	16
≥2000 and <2250	18
≥2250 and ≤2400	20
>2400	0

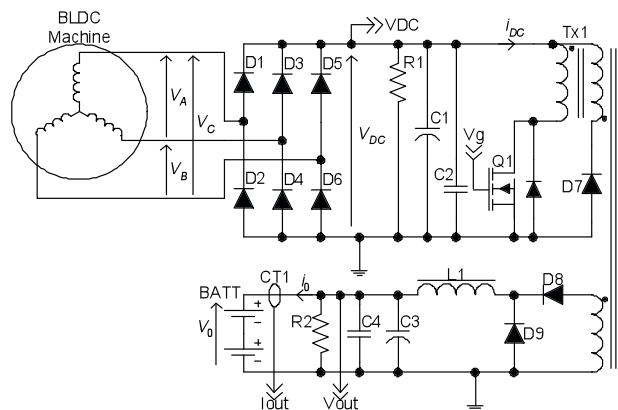

Fig. 7: Schematic diagram of the battery charger for automobile hybrid air conditioning system

Table 4: List of components of battery charger for the prototype of automobile hybrid air conditioning system

Components	Values/Model Number
R1	33kΩ
R2	3.9kΩ
C1	9400μF
C2	4.7μF
C3	100μF
C4	0.1μF
L1	28μH
Tx1	2:15:2, 16μH magnetizing inductance
D1 to D6	STPS1545D schottky diode
D7	MBR10100G schottky diode
D8 and D9	DSEK60-06A common cathode fast recovery epitaxial diode
CT1	LEM LA55-P/SP1 hall effect current transducer

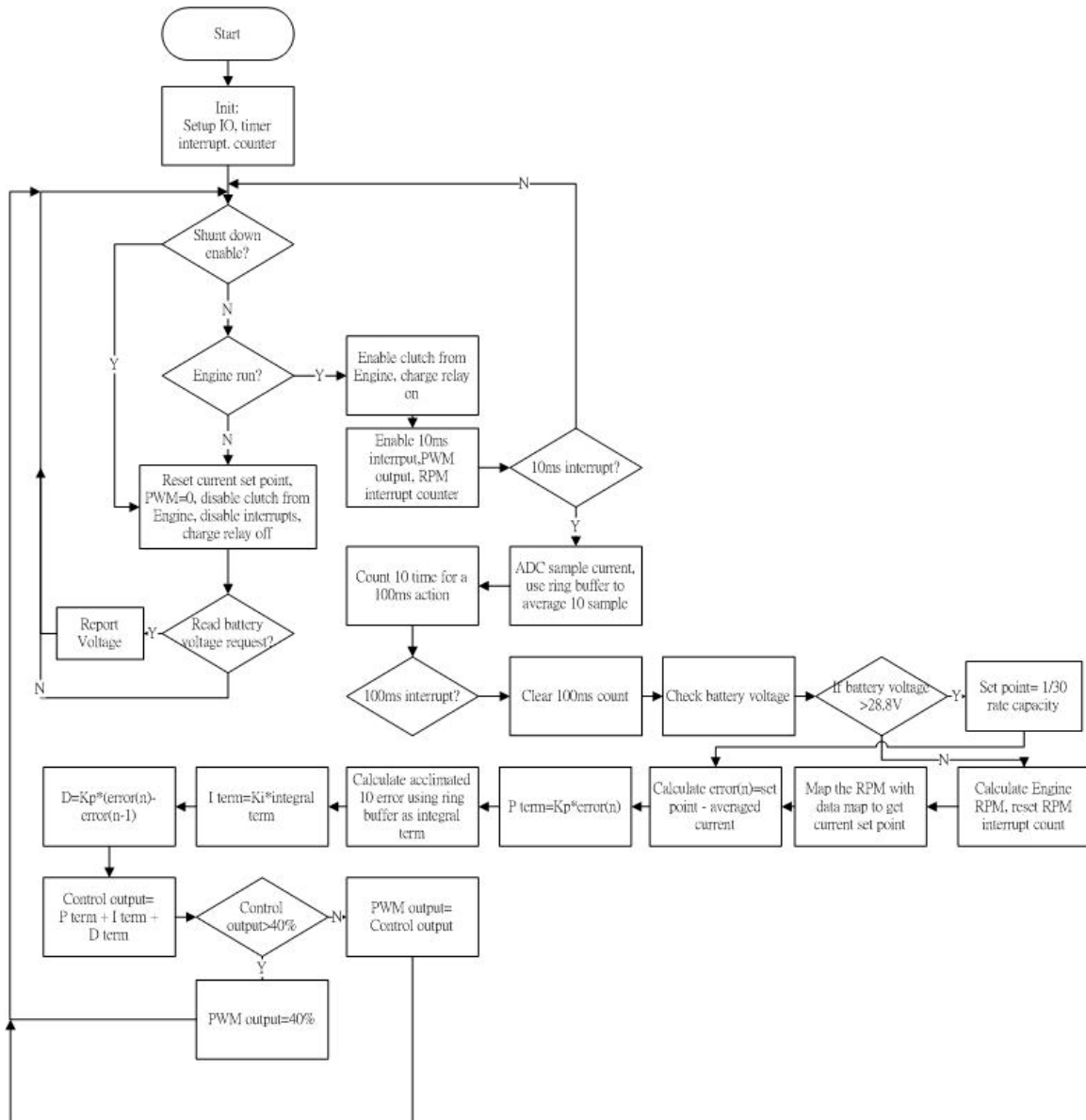

Fig. 8: Flow chart of controller programme of the battery charger for automobile hybrid air conditioning system

The control unit of the hybrid air conditioning system is a control system with an 8-bit MCU for switching on and off the clutches and the relays in different modes of operation. It is also responsible for controlling the room temperature by controlling the motor drive to vary the speed of the electric machine in Mode 3 or by switching on and off Clutch 2 in other modes of operation.

V. CONCLUSION

An automobile hybrid air conditioning system has been introduced. This air conditioning system can operate when the combustion engine of the vehicle is running, and operates for a short period when the vehicle is stop. For saving energy of the batteries, room temperature is controlled by the varying the speed of the electric machine when the vehicle is stop. It is a 24V DC system. The A/C compressor is driven by a combustion engine or a BLDC machine in different modes of operation. The electric machine is powered by two series connected 12V lead acid batteries. The electric machine generates electric

power for recharging batteries. The concept and the design of the prototype have been described.

ACKNOWLEDGEMENT

The authors gratefully acknowledge the financial support of Innovation and Technology Support Programme of the Innovation and Technology Commission, HKSAR and the Hong Kong Automotive Parts and Accessory Systems R&D Centre under the project number ITP/017/08AP.

REFERENCES

- [1] K. Iritani, K. Honda, H. Ieda, K. Matsunaga, T. Homan, M. Oomura, and Y. Takeo, "Air conditioner for hybrid vehicle", US Patent US 6,515,448 B2, 4 Feb 2003.
- [2] K. Iritani, "Air conditioner for hybrid vehicle", US Patent US 6,874,330 B2, 5 Apr. 2005.
- [3] X.Q. Li, J.P. Chen, Z.J. Chen, W.H. Liu, W. Hu and X.B. Liu, "A new method for controlling refrigerant flow in automobile air conditioning", Applied Thermal Engineering 24 (2004), 2004, pp. 1073-1085.